



Contents

1 General Description	1
2 Key Features.....	1
3 Applications.....	1
4 Pin Assignments	3
4.1 Pin Descriptions.....	3
5 Absolute Maximum Ratings	4
6 Electrical Characteristics.....	5
6.1 Operating Conditions.....	5
6.2 System Parameters	5
6.3 DC/AC Characteristics.....	6
7 Detailed Description.....	7
7.1 Operating Modes.....	7
7.1.1 Power Supply Filter.....	7
7.1.2 Reading an Angle	8
7.1.3 Low Power Mode	8
7.1.4 Interrupt Chaining	8
7.2 SPI Communication.....	9
7.2.1 Command Package	9
7.2.2 Read Package (Value Read from AS5055).....	9
7.2.3 Write Data Package (Value Written to AS5055).....	10
7.2.4 Register Block.....	10
7.2.5 SPI Interface Commands.....	11
7.2.6 Error Monitoring	14
8 Application Information	16
8.1 SPI Interface.....	16
8.1.1 SPI Interface Signals (4-Wire Mode, Wire_mode = 1).....	16
8.1.2 SPI Timing	17
8.1.3 SPI Connection to the Host μ C	18
8.1.4 SPI Over Long Distances	20
8.2 Placement of the Magnet.....	21
9 Package Drawings and Markings	22
10 Ordering Information	25



4 Pin Assignments

Figure 2. Pin Assignments (Top View)

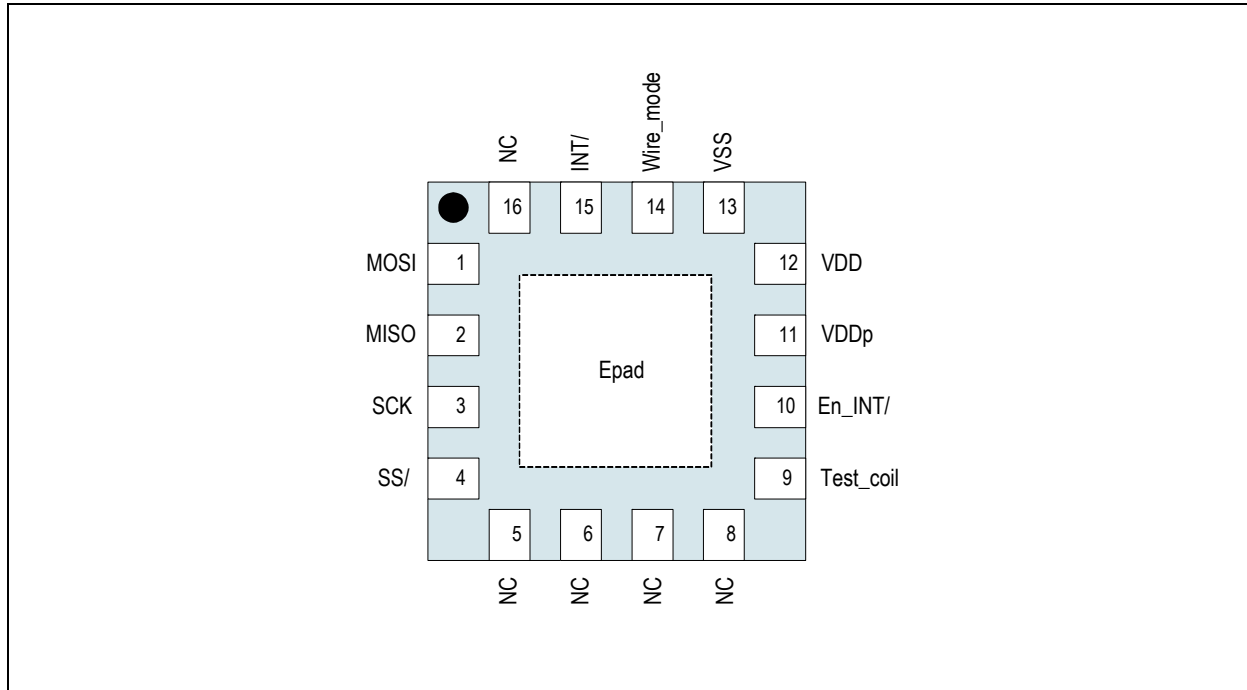

4.1 Pin Descriptions

Table 1. Pin Descriptions

Pin Number	Pin Name	Pin Type	Description
1	MOSI	Digital input	SPI bus data input
2	MISO	Digital output, tri-state buffer	SPI bus data output
3	SCK	Digital input Schmitt trigger	SPI Clock Schmitt trigger
4	SS/	Digital input	SPI Slave Select, active LOW
5	NC	-	Leave unconnected
6	NC		
7	NC		
8	NC		
9	Test coil	Supply	Test pin, connect to VSS
10	En_INT/	Digital input	Enable / disable Interrupt
11	VDDp	Supply	Peripheral power supply, 1.8V ~ VDD
12	VDD		Analog and digital power supply, 3.0 ~ 3.6V
13	VSS		Supply ground
14	Wire_mode	Digital I/O	0: 3-wire mode 1: 4-wire mode
15	INT/	Digital output, tri-state buffer	Interrupt output. Active LOW, when conversion is finished
16	NC	-	Leave unconnected
Epad	-	-	Center pad not connected



5 Absolute Maximum Ratings

Stresses beyond those listed in [Table 2](#) may cause permanent damage to the device. These are stress ratings only, and functional operation of the device at these or any other conditions beyond those indicated in [Electrical Characteristics on page 5](#) is not implied. Exposure to absolute maximum rating conditions for extended periods may affect device reliability.

Table 2. Absolute Maximum Ratings

Symbol	Parameter	Min	Max	Units	Comments
Electrical Parameters					
V _{DD}	DC supply voltage	-0.3	5.0	V	Value of these process dependent parameters to be taken from according Process Parameter document, current version
V _{DDp}	Peripheral supply voltage	-0.3	V _{DD} +0.3	V	
V _{IN}	Input pin voltage	-0.3	5.0	V	
I _{scr}	Input current (latchup immunity)	-100	100	mA	Norm: Jedec 78
Electrostatic Discharge					
ESD	Electrostatic discharge	±1	-	kV	Norm: MIL 883 E method 3015
θ _{JA}	Package thermal resistance	-	33.5	°C/W	Velocity=0, Multi Layer PCB; Jedec Standard Testboard
Continuous Power Dissipation					
P _t	Total power dissipation		36	mW	
Temperature Ranges and Storage Conditions					
T _{strg}	Storage temperature	-55	125	°C	
T _{BODY}	Package body temperature		260	°C	The reflow peak soldering temperature (body temperature) specified is in accordance with <i>IPC/JEDEC J-STD-020 "Moisture/Reflow Sensitivity Classification for Non-Hermetic Solid State Surface Mount Devices"</i> . The lead finish for Pb-free leaded packages is matte tin (100% Sn).
	Humidity non-condensing	5	85	%	
MSL	Moisture Sensitive Level		3		Represents a maximum floor life time of 168h



6 Electrical Characteristics

6.1 Operating Conditions

Table 3. Operating Conditions

Parameter	Conditions	Min	Typ	Max	Units
DC supply voltage	VDD	3.0		3.6	V
Peripheral supply voltage ¹	VDDp	1.8		VDD	V
Input pin voltage	V _{IN}	-0.3		VDDp +0.3	V
Ambient operating temperature		-40		85	°C
External component	Power supply filter, pin VDD (refer to Power Supply Filter on page 7)	2.2		4.7	μF
		15		33	Ω
	Ceramic capacitor, pin VDDp to VSS	100			nF

1. VDDp must not exceed VDD (protection diode between VDDp and VDD)

6.2 System Parameters

Table 4. System Parameters

Symbol	Parameter	Conditions	Min	Typ	Max	Units
I ₁₀	Operating current	Average current @ 10 ms readout rate ¹			0.4	mA
I ₁₀₀	Operating current	Average current @ 100 ms readout rate			40	μA
I _{max}	Operating current	Maximum readout rate			8.5	mA
	Readout rate	Time between READ ANGLE command and INTERRUPT	320		430	μs
	Power down current	Power down current			3	μA
R _d	Lateral displacement range	Centre of the magnet to the centre of the die	-		± 0.5	mm
B _z	Magnetic field strength		30	-	80	mT
	Serial interface	SPI mode 1 (CPOL = 0 / CPHA =1)				
	Resolution; magnetic field measurement			12		bit
	Resolution; angle			12		bit
	INL	Best-fit line - over supply, displacement and temperature – but without quantization	-1.41		1.41	degree
	IC package		QFN 4x4x0.85			

1. Without the time for the SPI interface



6.3 DC/AC Characteristics

Digital pads: MISO, MOSI, SCK, SS/, EN_INT/, INT/, Wire_mode

Table 5. DC/AC Characteristics

Symbol	Parameter	Conditions	Min	Typ	Max	Units
V _{IH}	High level input voltage		0.7 * VDD _p			V
V _{IL}	Low level input voltage	VDD _p > 2.7V			0.3 * VDD _p	V
V _{IL}	Low level input voltage	VDD _p < 2.7V			0.25 * VDD _p	V
I _{LEAK}	Input leakage current				1	μA
V _{OH}	High level output voltage		VDD _p - 0.5			V
V _{OL}	Low level output voltage				VSS + 0.4	V
C _L	Capacitive load				35	pF



7 Detailed Description

User Programming.

The AS5055 does not require any programming by the user. A dedicated on-chip zero position programming is not implemented. If a zero position programming is required, it is recommended to store the zero position offset in the host controller.

7.1 Operating Modes

Typical Application.

The AS5055 requires only a few external components in order to operate immediately when connected to the host microcontroller. Only 6 wires are needed for a simple application using a single power supply: two wires for power and four wires for the SPI communication. A seventh connection can be added in order to send an interrupt to the host CPU to inform that a new valid angle can be read. For additional information on the layout and filtering of the SPI, please refer to [Section 8.1.4 SPI Over Long Distances](#).

Figure 3. Typical Application Using SPI 4-Wire Mode and INT/ Output

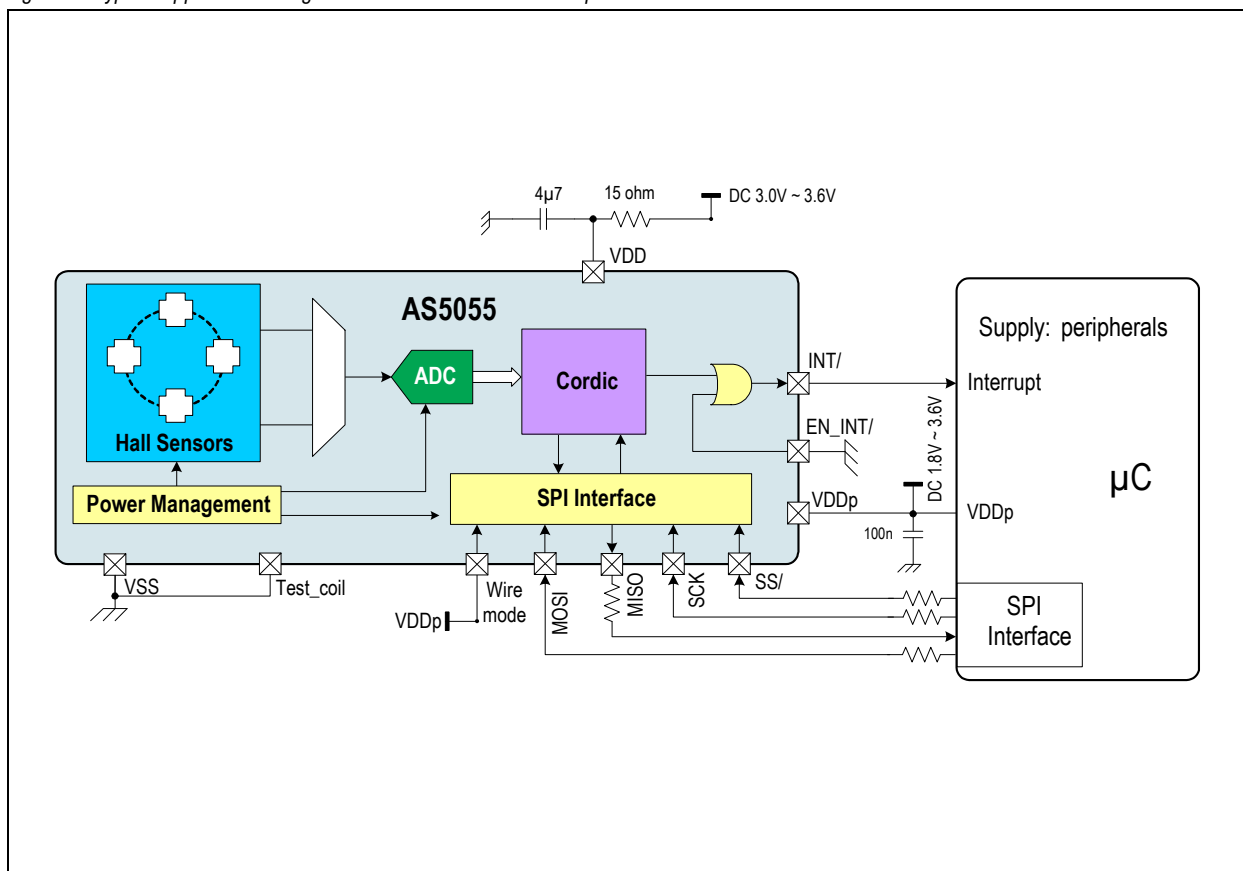

Upon power-up, the AS5055 performs a full power-up sequence including one angle measurement. The completion of this cycle is indicated at the INT/ output pin and the angle value is stored in an internal register. Once this output is low active, the AS5055 suspends to sleep mode.

7.1.1 Power Supply Filter

Due to the sequential internal sampling of the Hall sensors, fluctuations on the analog power supply (pin#12: VDD) may cause additional jitter of the measured angle. This jitter can be avoided by providing a stable VDD supply.

The easiest way to achieve that is to add a RC filter: $15\Omega + 4.7\mu\text{F}$ in the power supply line as shown in [Figure 3](#).

Alternatively, a filter: $33\Omega + 2.2\mu\text{F}$ may be used. However with this configuration, the minimum supply voltage is 3.15V.



7.1.2 Reading an Angle

The external microcontroller can respond to the INT request by reading the angle value from the AS5055 over the SPI interface. Once the angle value is read, the INT output is cleared again.

Sending a "read angle" command by the SPI interface also automatically powers up the chip and starts another angle measurement. As soon as the microcontroller has completed reading of the angle value, the INT output is cleared and a new result is stored in the angle register. The completion of the angle measurement is again indicated by setting the INT output and a corresponding flag in the status register.

Reducing the Angle Jitter. Due to the measurement principle of the chip, only a single angle measurement is performed in very short time after each power-up sequence. As soon as the measurement of one angle is completed, the chip suspends to power-down state. An on-chip filtering of the angle value by digital averaging is not implemented, as this would require more than one angle measurement and consequently, a longer power-up time which is not desired in low-power applications.

The angle jitter can be reduced by averaging of several angle samples in the external microcontroller. For example, an averaging of 4 samples reduces the noise related jitter by 6dB (50%).

7.1.3 Low Power Mode

After completing the readout of an angle value, the device is in very low power condition. The AS5055 remains in sleep mode until it receives another angle reading request over the SPI interface. The average power consumption therefore depends on the interval, at which the external controller reads an angle over the SPI Interface. The timing ratio between active and sleep phase:

(EQ 1)

$$I_{avg} = \frac{t_{on} * I_{on} + t_{off} * I_{off}}{t_{on} + t_{off}}$$

Where:

t_{on} = Minimum on-time for power-up and angle measurement	430 μ s
t_{off} = Pause interval between measurements, determined by the polling rate of the external microcontroller	
I_{on} = Current consumption in active mode	8.5mA (maximum)
I_{off} = Current consumption in sleep mode	3 μ A

Examples:

3000 measurements per second (continuous mode)	$I = 8.5\text{mA}$
1000 measurements per second	$I_{avg} = 3.7\text{mA}$
100 measurements per second	$I_{avg} = 370\mu\text{A}$
10 measurements per second	$I_{avg} = 40\mu\text{A}$

Note: Even in low power mode, the power supply must be capable of supporting the active current at least for the time T_{on} , until the AS5055 is suspended to sleep mode.

7.1.4 Interrupt Chaining

Every chip contains a configurable gate to combine its own internally generated interrupt signal with a signal applied externally over the XENINT-pin. The INT-mode register is preset via an OTP register and can be overwritten by the SPI interface.

Case A.

Device A is set to mode 0

Device B is set to mode 0

The micro controller recognizes an interrupt if both devices signalize that the computation is finished.

Case B.

Device A is set to mode 0

Device B is set to mode 1

The micro controller recognizes an interrupt if one of the two devices signalize that the computation is finished.



Figure 4. Interrupt Chaining

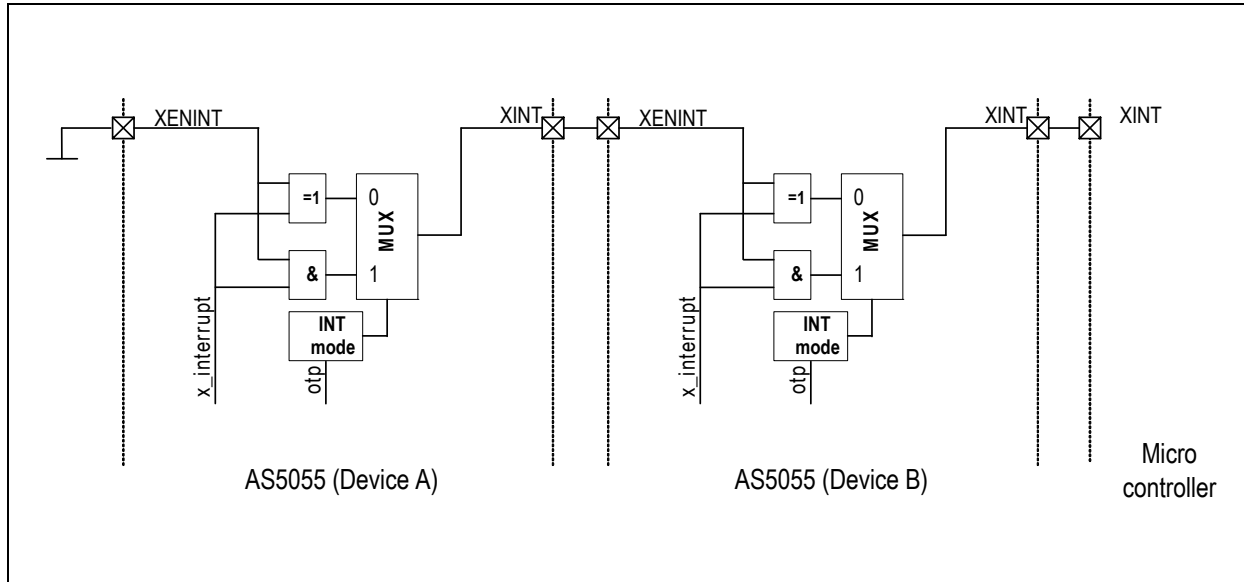

7.2 SPI Communication

The transmitted data consists of 14-bit data, an Error-Flag and a Parity bit. When writing data to the chip, the Error-Flag is not applicable. The Parity is generated from the upper 15 bits and forms an even parity over the whole frame. The Error-Flag indicates that a failure occurred in a previous transmission.

7.2.1 Command Package

Every command sent to the AS5055 is represented with the following layout.

Table 6. Command Package

Bit	MSB	14	13	12	11	10	9	8	7	6	5	4	3	2	1	LSB
	RWn	Address <13:0>														PAR

Bit	Description
RWn	Indicates read or write command
Address	14-bit address code
PAR	Parity bit (EVEN)

7.2.2 Read Package (Value Read from AS5055)

The read frame always contains two alarm bits, the error and parity flags and the addressed data of the previous read command.

Table 7. Read Package

Bit	MSB	14	13	12	11	10	9	8	7	6	5	4	3	2	1	LSB	
		Data <13:0>														EF	PAR

Bit	Description
Data	14-bit addressed data
EF	Error flag indicating a transmission error in a previous host transmission
PAR	Parity bit (EVEN)



7.2.3 Write Data Package (Value Written to AS5055)

The write frame is compatible to the read frame and contains two additional bits, the don't care and parity flag.

If the previous command was a write command a second package has to be transmitted.

Table 8. Write Package

Bit	MSB	14	13	12	11	10	9	8	7	6	5	4	3	2	1	LSB
Data <13:0>															Don't care	PAR

Bit	Description
Data	14-bit data to write to former selected address
PAR	Parity bit (EVEN)

7.2.4 Register Block

Table 9. Register Block

Register	Bit	Mode	Reset Value	Bit	Description
Power ON Reset (POR) Register - [0x3F22]					
POR_OFF	8	R/W	0x00	<7:0>	The POR cell is deactivated when the value 0x5A is written to this register (30µA reduction of current consumption)
Software Reset Register - [0x3C00]					
software_reset	14	W	0x000	<13:0>	Refer to SOFTWARE RESET Command on page 13
Master Reset Register - [0x33A5]					
master_reset	14	W	0x000	<13:0>	Inject a power on reset cycle
Clear Error Flag Register - [0x3380]					
clr_error_flag	14	R	0x000	<13:0>	Refer to CLEAR ERROR FLAG Command on page 12
No Operation Register - [0x0000]					
NOP	14	w	0x000	<13:0>	Refer to NOP Command on page 14
Automatic Gain Control (AGC) Register - [0x03FF8]					
AGC	6	R/W	0x20	<5:0>	Automatic gain control: low values = strong magnetic field high values = weak magnetic field
Angular Data - [0x3FFF]					
Angle Value	12	R	0x000	<11:0>	Measured angular value, 12-bit
Alarm LO	1	R	0	<12>	Alarm bit indicating a too high magnetic field, active HIGH. Refer to Error Monitoring on page 14
Alarm HI	1	R	0	<13>	Alarm bit indicating a too low magnetic field, active HIGH. Refer to Error Monitoring on page 14
System Configuration Register 1 - [0x3F20]					
resolution	2	R	'00'	<13:12>	'00' indicates 12-bit resolution
chip ID	3	R	'001'	<11:9>	Silicon version 001
Error Status Register - [0x335A]					
error_status	14	R	0x000	<13:0>	Refer to Error Status Command on page 15



7.2.5 SPI Interface Commands

READ Command. For a single READ command two transmission sequences are necessary. The first package written to the AS5055 contains the READ command (**MSB high**) and the address the chip has to access, the second package transmitted to the AS5055 device can be any command the chip has to process next. The content of the desired register is available in the MISO register of the master device at the end of the second transmission cycle.

Figure 5. READ Command

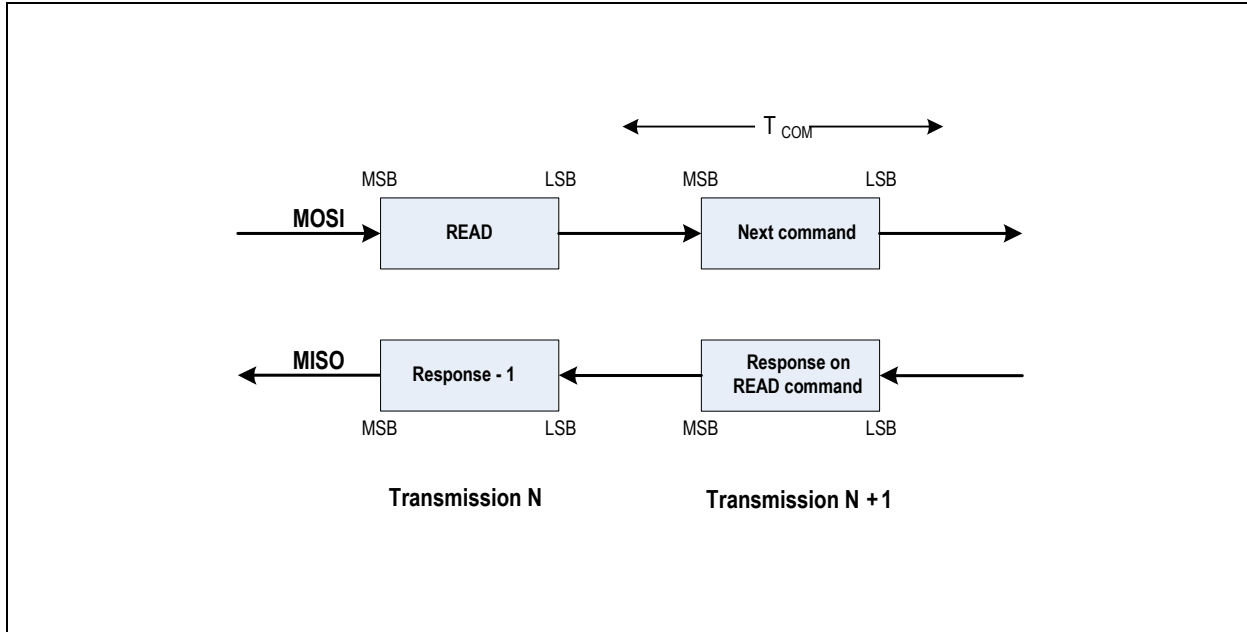

WRITE Command. A single WRITE command takes two transmission cycles. The WRITE command can be verified by sending a NOP command after the WRITE command. The Data will be send back during NOP command.

Figure 6. WRITE Command

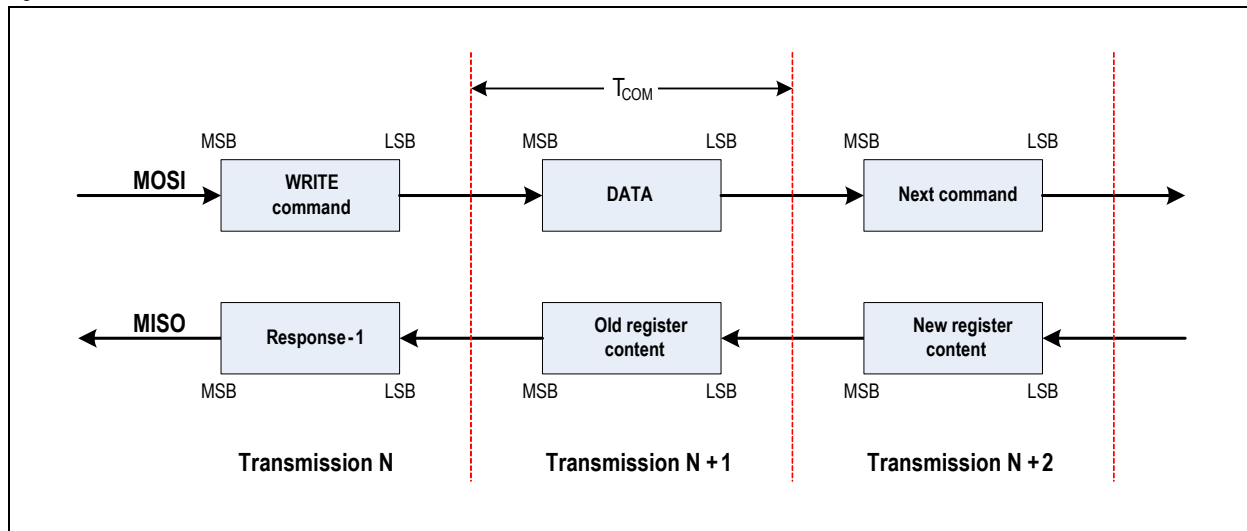



CLEAR ERROR FLAG Command. The CLEAR ERROR FLAG command is implemented as READ command. This command clears the ERROR FLAG which is contained in every READ frame. The READ data are 0x0000, which indicates a successful clear command.

Figure 7. CLEAR ERROR FLAG Command

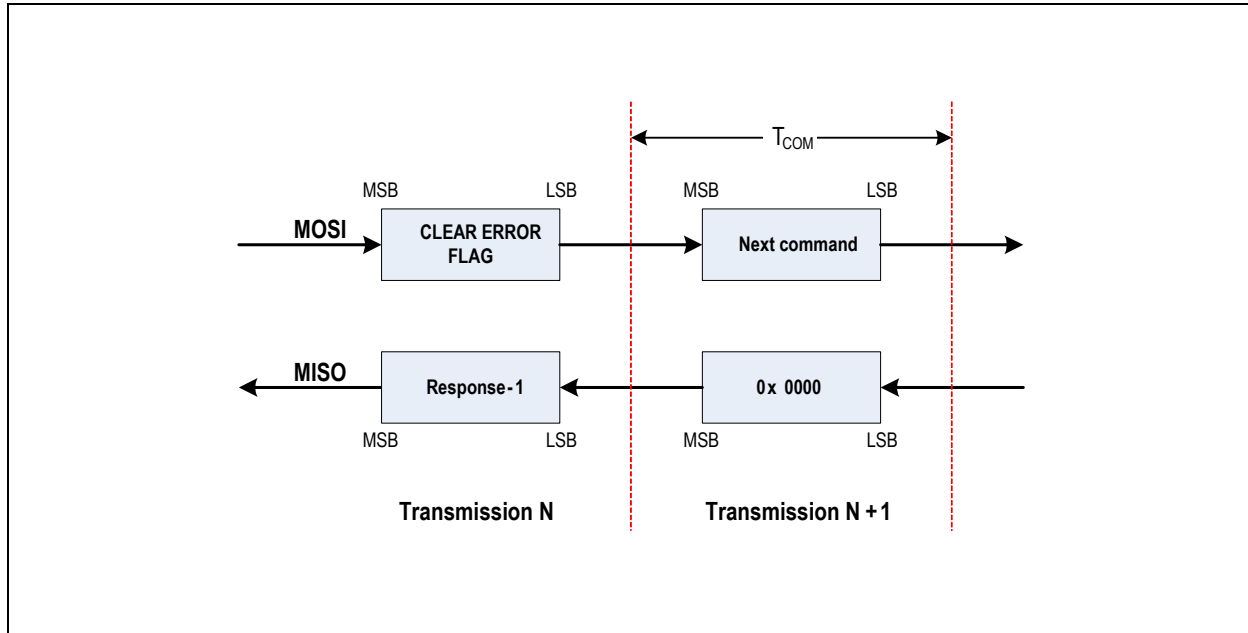

The package necessary to perform a CLEAR ERROR FLAG is built up as follows.

Table 10. CLEAR ERROR FLAG Command

Bit	MSB	14	13	12	11	10	9	8	7	6	5	4	3	2	1	LSB
	1	1	1	0	0	1	1	1	0	0	0	0	0	0	0	PAR
	CLEAR ERROR FLAG command															PAR

Possible conditions which force the ERROR FLAG to be set:

- Wrong parity
- Wrong command
- Wrong number of clocks (no full transmission cycle or too many clocks)

Note: If the error flag is set to 'high' because of a communication problem the flag remains set until it will be cleared by an external command.



SOFTWARE RESET Command. The SOFTWARE RESET command is implemented as WRITE command. The bit 'RES SPI' of the DATA package indicates if the SPI registers should be reset as well. The soft reset resets the digital part ('RES SPI' is set to one) as well as the OTP memory. A new OTP memory auto-load is initiated and the reset values stored in the OTP memory are loaded into the configuration registers. The command following the SOFTWARE RESET command can be any of the commands specified in this chapter.

After the data package is sent, the soft reset is generated. The fuses of the OTP memory are loaded into the registers and a new conversion cycle will be started. If the device is in sleep mode the oscillator will be started first.

Figure 8. SOFTWARE RESET Command

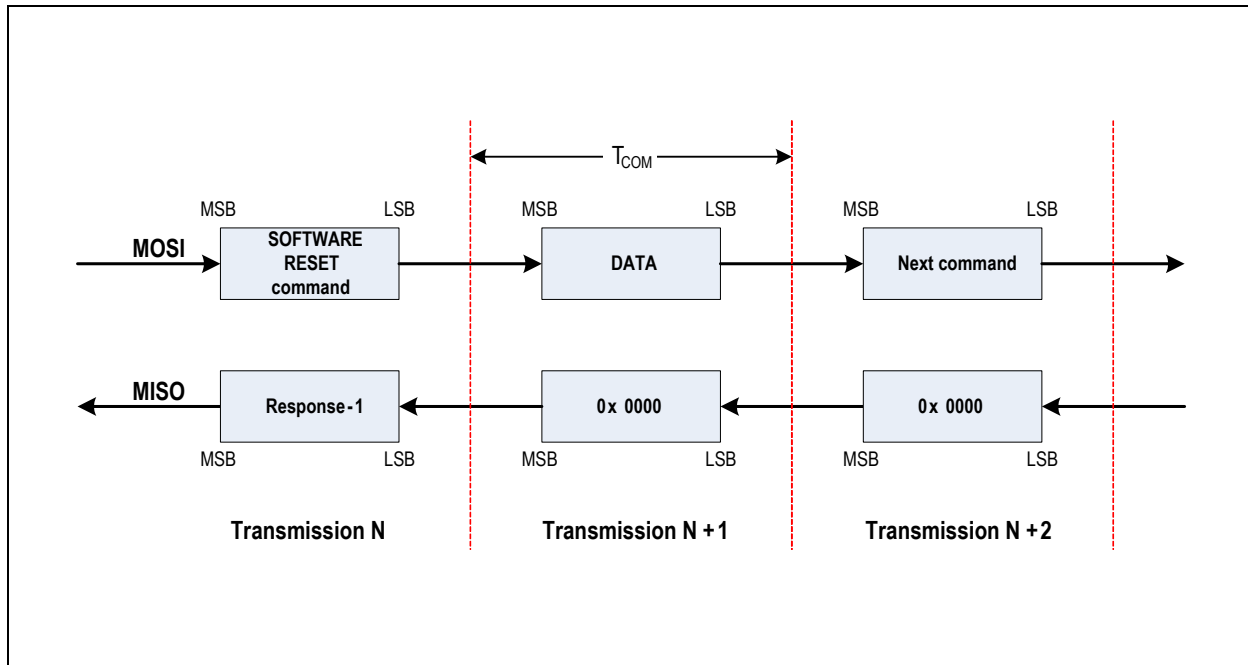

In order to invoke a software reset on the AS5055 the following bit pattern has to be sent.

Table 11. SOFTWARE RESET Command

Bit	MSB	14	13	12	11	10	9	8	7	6	5	4	3	2	1	LSB
	0	1	1	1	1	0	0	0	0	0	0	0	0	0	0	PAR
	SOFTWARE RESET command															PAR

Table 12. Data Package

Bit	MSB	14	13	12	11	10	9	8	7	6	5	4	3	2	1	LSB
	Don't care													RES SPI	Don't care	PAR

Bit	Description
RES SPI	If set to one, SPI registers are reset as well ¹
PAR	Parity bit (EVEN)

1. After a power on reset, the OTP will be read and hence OTP related registers are changed independent on the RES SPI flag.



NOP Command. The NOP command represents a dummy write to the AS5055.

Figure 9. NOP Command

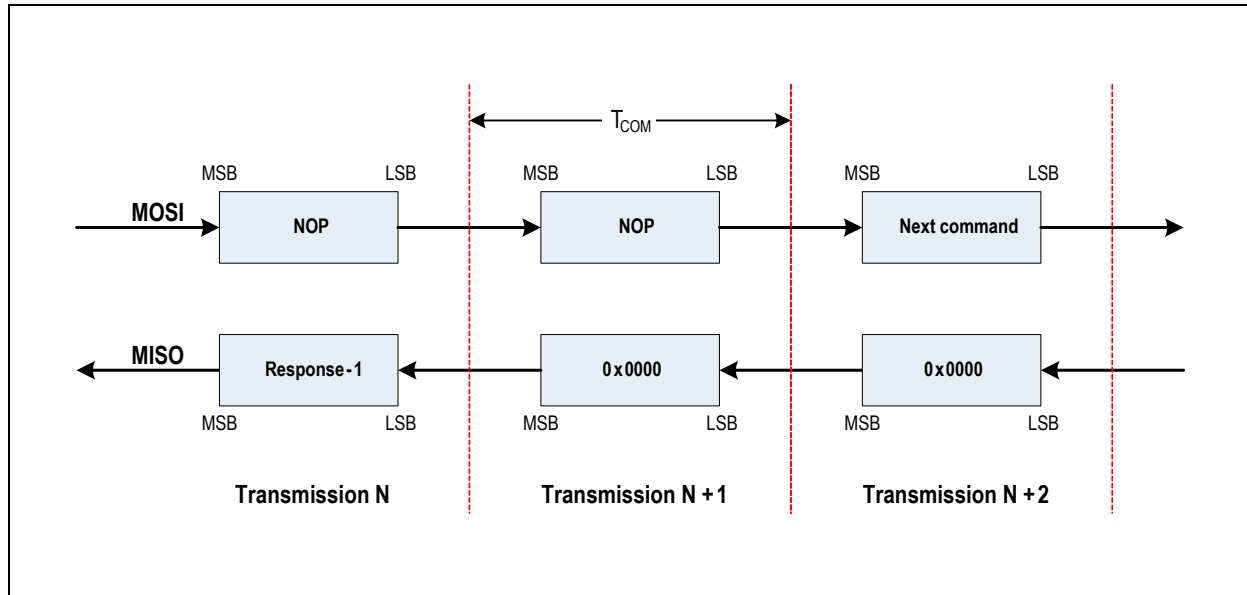

The NOP command frame looks like follows.

Table 13. NOP Command

Bit	MSB	14	13	12	11	10	9	8	7	6	5	4	3	2	1	LSB
	0	0	0	0	0	0	0	0	0	0	0	0	0	0	0	
NOP command (0x0000)																

The chip's response on this command is 0x0000 – if no error happens.

7.2.6 Error Monitoring

The correct operation and communication of the AS5055 is ensured by several particular error flags. Every read access is supported by an error flag (EF) to indicate a transmission error. In addition a dedicated error status register is accessible. See [Table 14 on page 15](#).

Alarm HI	Alarm LO	Mode Description
0	0	AGC level is higher than the minimum value and lower than the maximum value
0	1	AGC level is equal or even lower than the minimum level
1	0	AGC level is equal or even higher than the maximum level
1	1	Indicates if any error flag has occurred. For detailed information, refer to Error Status Command on page 15 .



Error Status Command.

Table 14. Error Status Command

Description	Error Status DSP						Error Status System				Error Status SPI			
Bit	13	12	11	10	9	8	7	6	5	4	3	2	1	0
Type	reserved	DSPAHI	DSPALO	RANERR	DSPOV	DACOV	reserved	MODE	WOW	reserved	ADDMON	CLKMON	PARITY	

PARITY: Indicates when the transmitted parity bit does not match to calculated parity bit

CLKMON: Clock monitoring indicates when the amount of clock cycles is not correct

ADDMON: Address monitoring appears when the address does not exist

WOW: This is a handshake mechanism to check system integrity. By sending a READ ANGLE command the internal flag (WOW) is set to high. At the end of measurement the WOW is set to low again. In failure case (internal dead lock situation) the WOW flag remains high.

MODE: During sleep mode, the flag is 0. When the IC is busy (measuring), the flag is 1.

DACOV: The DACOV bit occurs if the magnetic input field strengths is too large for at least one Hall element. This can be the case if the magnet is displaced.

DSPOV: CORDIC overflow occurs when the input signals of CORDIC are too large

RANERR: Range error appears when the voltage drop over the internal current source decreases which is caused by increased temperature. The accuracy is getting worse.

DSPALO: DSP Alarm LO; AGC level is equal or even lower than the minimum level.

DSPAHI: DSP Alarm HI; AGC level is equal or even higher than the maximum level.

For additional information on Error Status, please refer to the application note **AN5000_Error Monitoring**.



8 Application Information

The benefits of the AS5055 device are as follows:

- Complete system-on-chip
- Low power consumption
- Low operating voltage
- Easy to use SPI interface

8.1 SPI Interface

The 16-bit SPI Interface enables read / write access to the register blocks and is compatible to a standard micro controller interface. The SPI module is active as soon as /SS pin is pulled low. The AS5055 then reads the digital value on the MOSI (master out slave in) input with every falling edge of SCK and writes on its MISO (master in slave out) output with the rising edge. After 16 clock cycles /SS has to be set back to a high status in order to reset some parts of the interface core. The SPI Interface can be set in two different modes: 3-wire mode or 4-wire mode.

Notes:

1. The wire mode selection is read during the POWER-UP state and can be changed with a power on reset or a software reset command.
2. For more stability on the SPI Interface, it is very important to place filters. The filter must be placed close to the driving outputs. For further information, please refer to the application note **AN5000_SPI_Interface**.

Table 15. Wire Mode Selection

Wire Mode Selection (pad 14)	
wire_mode = LO	3-wire mode
wire_mode = HI	4-wire mode

8.1.1 SPI Interface Signals (4-Wire Mode, Wire_mode = 1)

The AS5055 only supports slave operation mode. Therefore SCK for the communication as well as the /SS signal has to be provided by the test equipment. The following picture shows a basic interconnection diagram with one master and an AS5055 device and a principle schematic of the interface core.

Figure 10. SPI Interface Connection

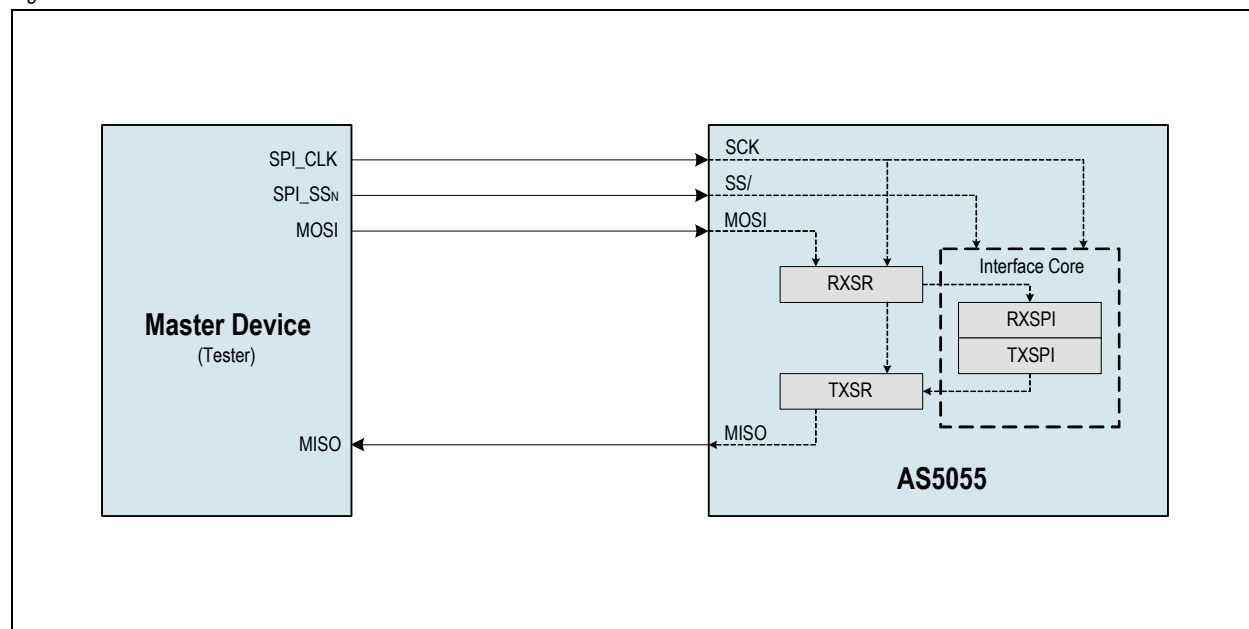

Because the interface has to decode the sent command before it can react and provide data the response of the chip to a specific command applied at a time T can be accessed in the next transmission cycle ending at T + TCOM.



The data are sent and read with **MSB first**. Every time the chip is accessed it is sending and receiving data.

Figure 11. SPI Command / Response Data Flow

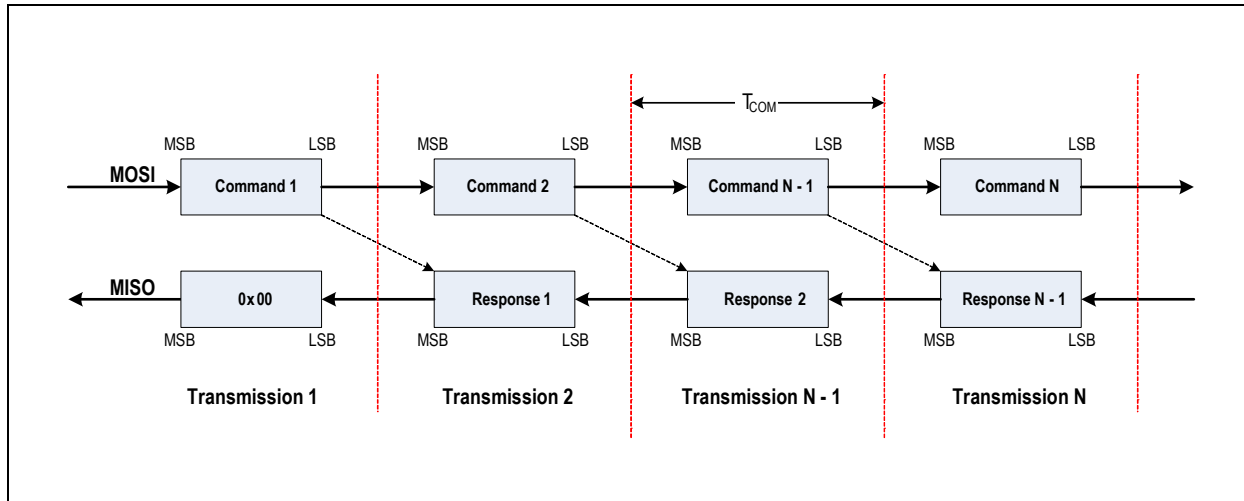

8.1.2 SPI Timing

Figure 12. SPI Timing Diagram

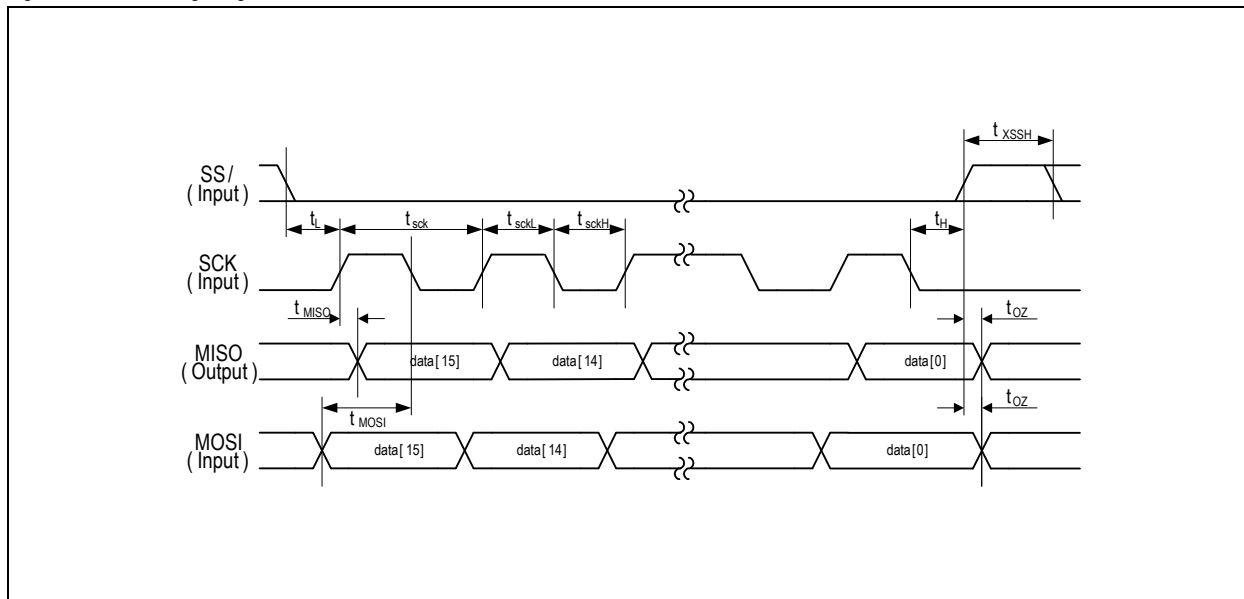

Table 16. SPI Timing Characteristics

Parameter	Description	Min	Max	Unit
t _{OZ}	Time between positive edge of SS/ to output high impedance		50	ns
t _L	Time between SS/ falling edge and SCK rising edge	10		ns
t _{SCK}	Serial clock period	100		ns
t _{SCKL}	Low period of serial clock	50		ns
t _{SCKH}	High period of serial clock	50		ns
t _H	Time between last falling edge of SCK and rising edge of SS/	t _{SCK} / 2		ns



Table 16. SPI Timing Characteristics

Parameter	Description	Min	Max	Unit
t_{XSSH}	High time of SS/ between two transmissions	50		ns
t_{MOSI}	Data input valid to clock edge	20		ns
t_{MISO}	SCK edge to data output valid		20	ns

8.1.3 SPI Connection to the Host μ C

Single Slave Mode.

Figure 13. Single Slave Mode

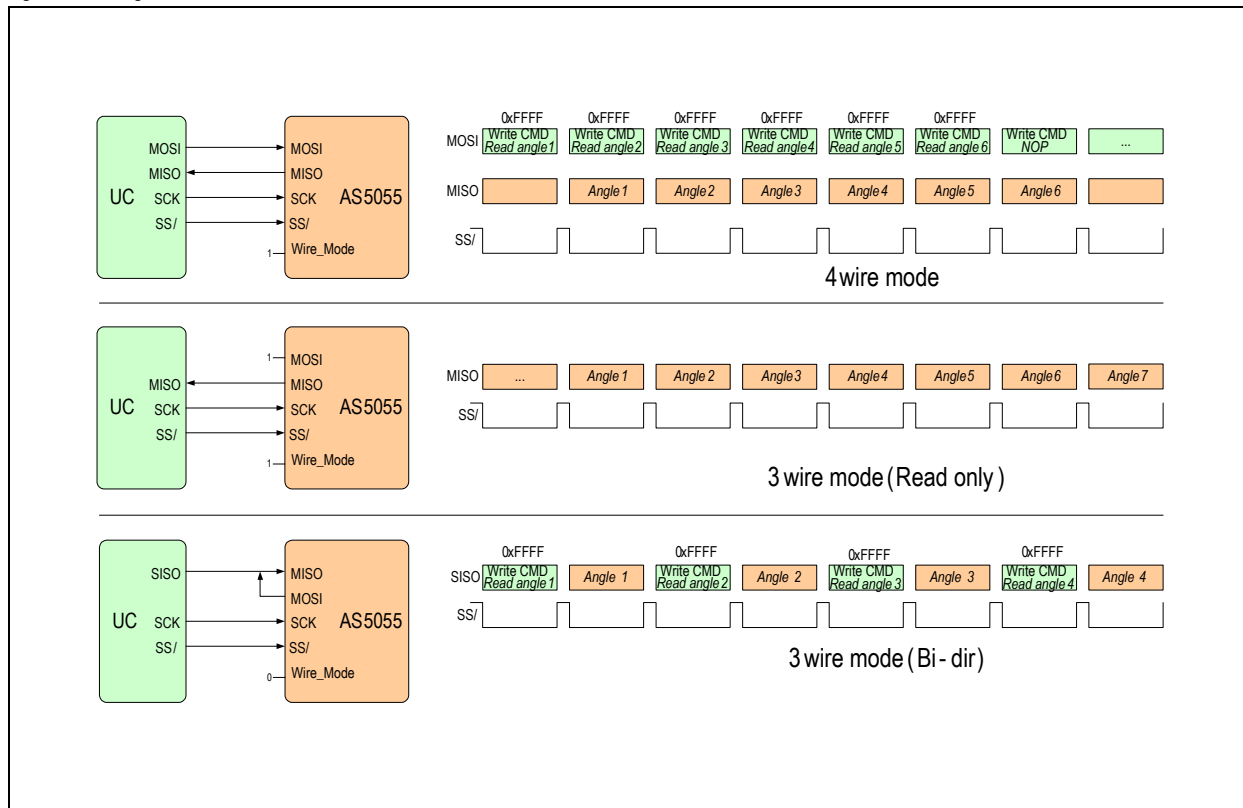

Note: 3 Wire Mode (read only): If the ERROR FLAG is set the device must be externally reset.



Multiple Slave, n+3 Wire (Separate ChipSelect).

Figure 14. Multiple Slave, n+3 Wire (Separate ChipSelect)

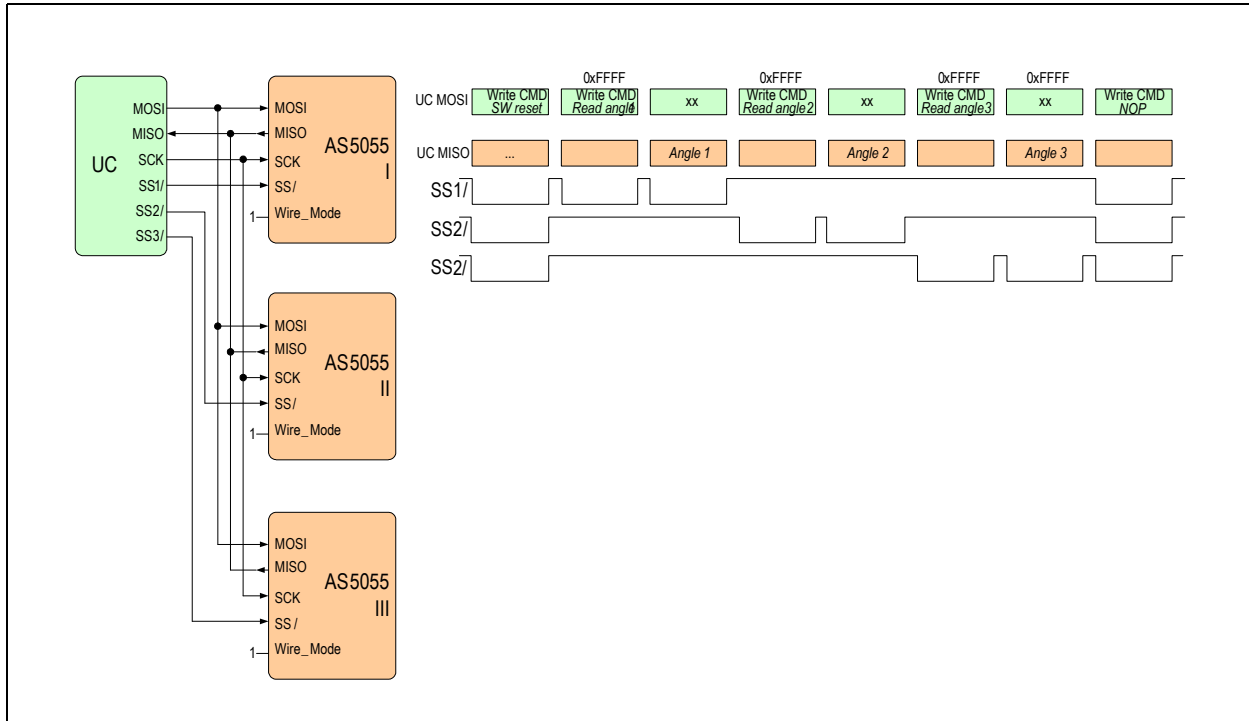

Daisy Chain, 4 Wire.

Figure 15. Daisy Chain, 4-Wire

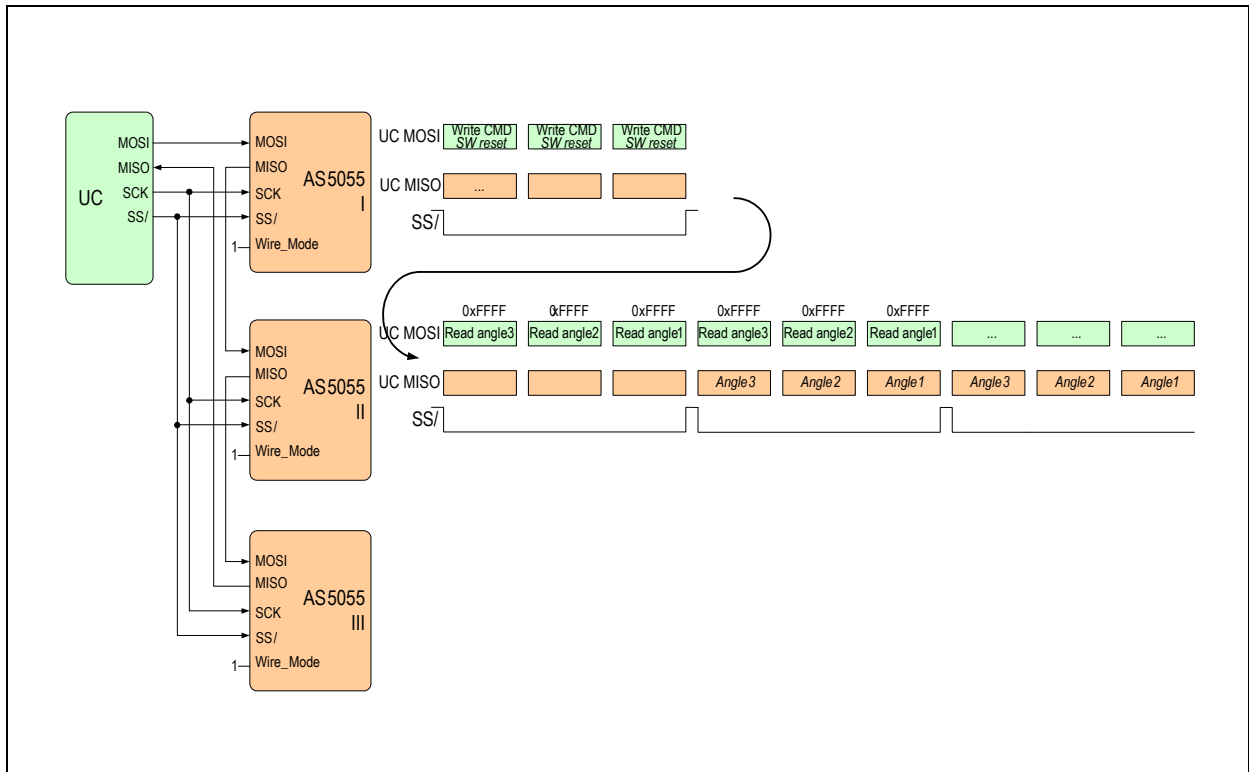



8.1.4 SPI Over Long Distances

Over long cable distances you will have coupling capacitance between signals. Therefore consider some aspects.

The circuitry of the connection is shown in [Figure 16](#).

Figure 16. Circuitry of SPI Over Long Distances

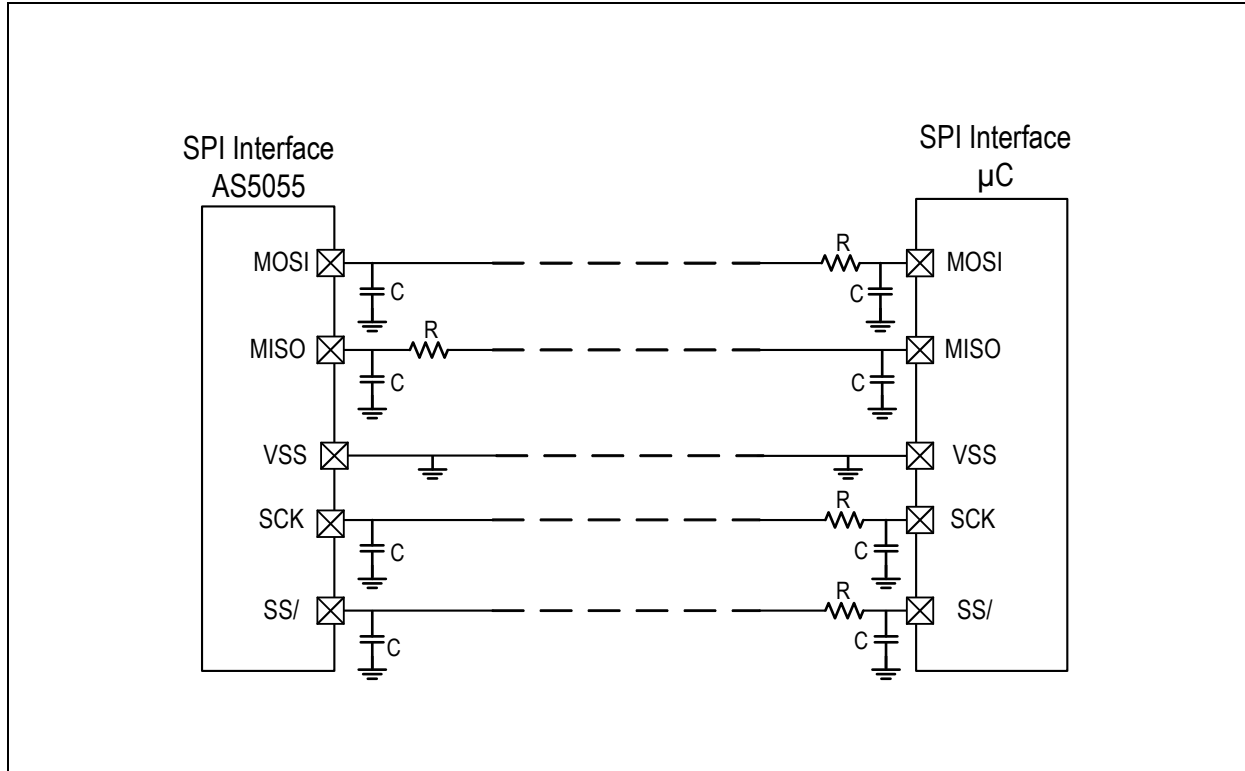

One aspect is that between MISO and SCK must be separated with VSS. Additionally filter circuitry, reduces the disturbance to a minimum. Resistors close to the output pins reduce communication noise and increase EMC.

Required resistors on the output pins are between 100 Ohm and 1000 Ohm. Required capacitance is 100pF.

Place the resistors and capacitors as near as possible to the pins.

For additional information on this issue, please refer to the application note [AS5055_SPI_APPNote](#).



8.2 Placement of the Magnet

Non-Linearity Error over Displacement.

As shown in [Figure 18](#), the recommended horizontal position of the magnet axis is over the diagonal center of the IC.

[Figure 17](#) shows a typical error curve at a vertical magnet distance of 1.0mm, measured with a NdFeB N35H magnet with 6mm diameter and 2.5mm height.

The X- and Y- axis of the graph indicate the lateral displacement of the magnet center with respect to the IC center.

At $X = Y = 0$, the magnet is perfectly centered over the IC. The total displacement plotted on the graph is for ± 1 mm in both directions.

The Z-axis displays the worst case INL error over a full turn at each given X-and Y-displacement. The error includes the quantization error of $\pm \frac{1}{2}$ LSB. At the sample shown in [Figure 17](#), the accuracy for a centered magnet is better than 0.5° . Within a radius of 0.5mm, the accuracy is about 1.0° (spec = 1.41° over temperature).

Figure 17. Integral Non-linearity Over Displacement of the Magnet

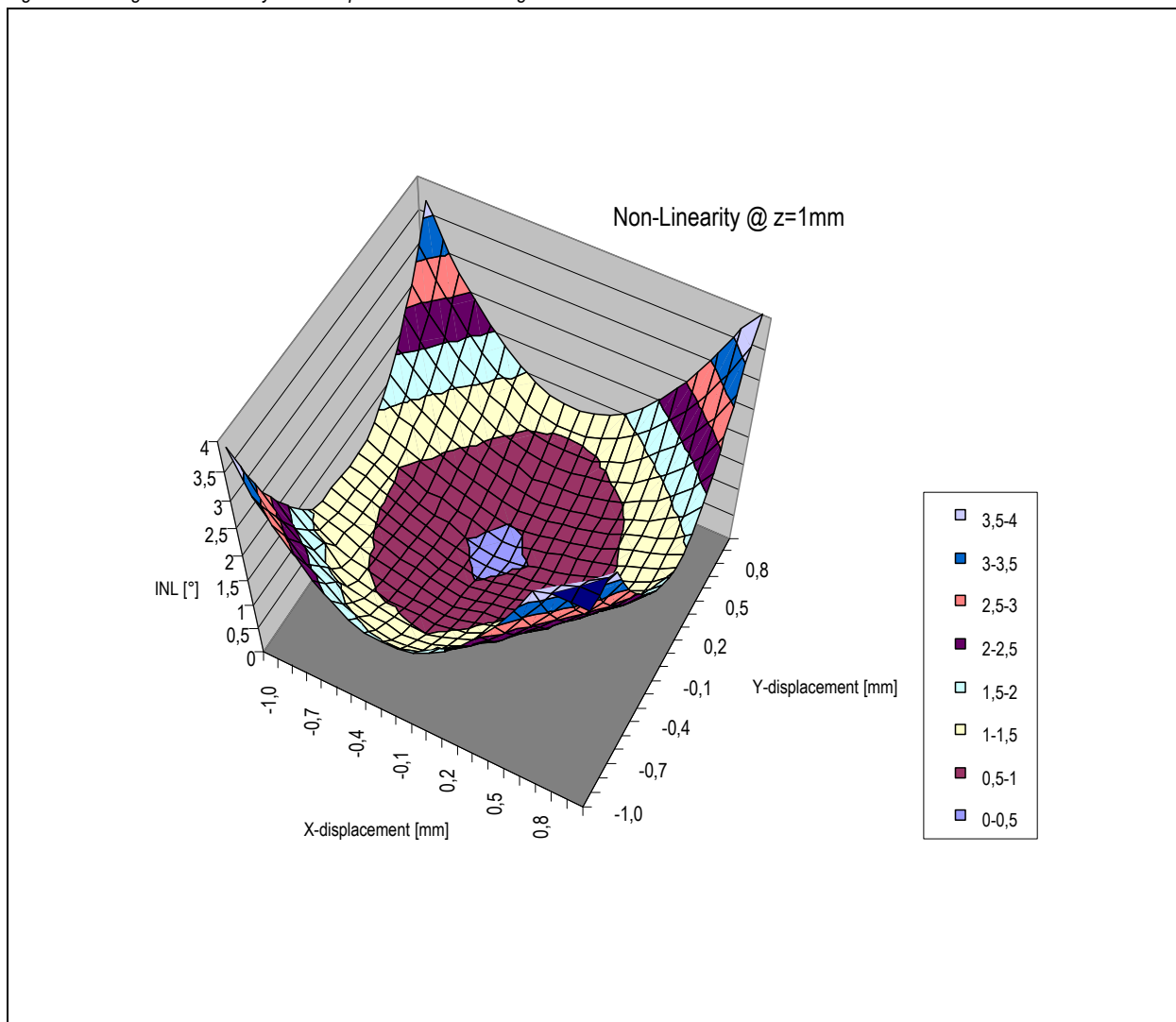



9 Package Drawings and Markings

The device is available in a 16-pin QFN (4x4x0.85 mm) package.

Figure 18. Drawings and Dimensions

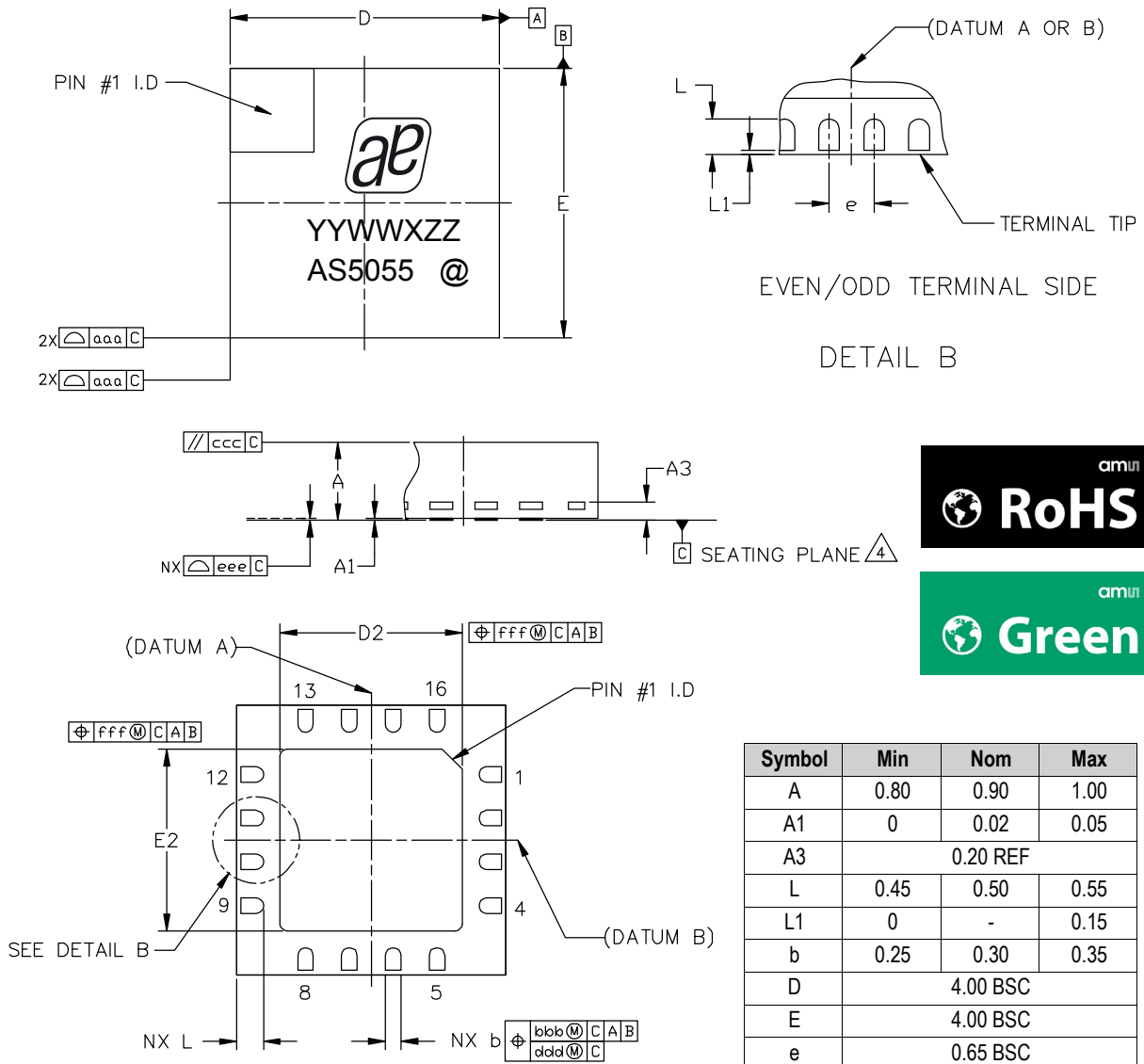

Symbol	Min	Nom	Max
A	0.80	0.90	1.00
A1	0	0.02	0.05
A3	0.20 REF		
L	0.45	0.50	0.55
L1	0	-	0.15
b	0.25	0.30	0.35
D	4.00 BSC		
E	4.00 BSC		
e	0.65 BSC		
D2	2.30	2.40	2.50
E2	2.30	2.40	2.50
aaa	-	0.15	-
bbb	-	0.10	-
ccc	-	0.10	-
ddd	-	0.05	-
eee	-	0.08	-
fff	-	0.10	-
N	16		

- Notes:**
1. Dimensions and tolerancing conform to ASME Y14.5M-1994.
 2. All dimensions are in millimeters. Angles are in degrees.
 3. Dimension b applies to metallized terminal and is measured between 0.25mm and 0.30mm from terminal tip. Dimension L1 represents terminal full back from package edge up to 0.15mm is acceptable.
 4. Coplanarity applies to the exposed heat slug as well as the terminal.
 5. Radius on terminal is optional.
 6. N is the total number of terminals.

Marking: YYWWXZZ.

YY	WW	X	ZZ	@
Year (i.e. 04 for 2004)	Week	Assembly plant identifier	Assembly traceability code	Sublot identifier



Figure 19. Vertical Cross Section of 16-pin QFN (4x4x0.85 mm)

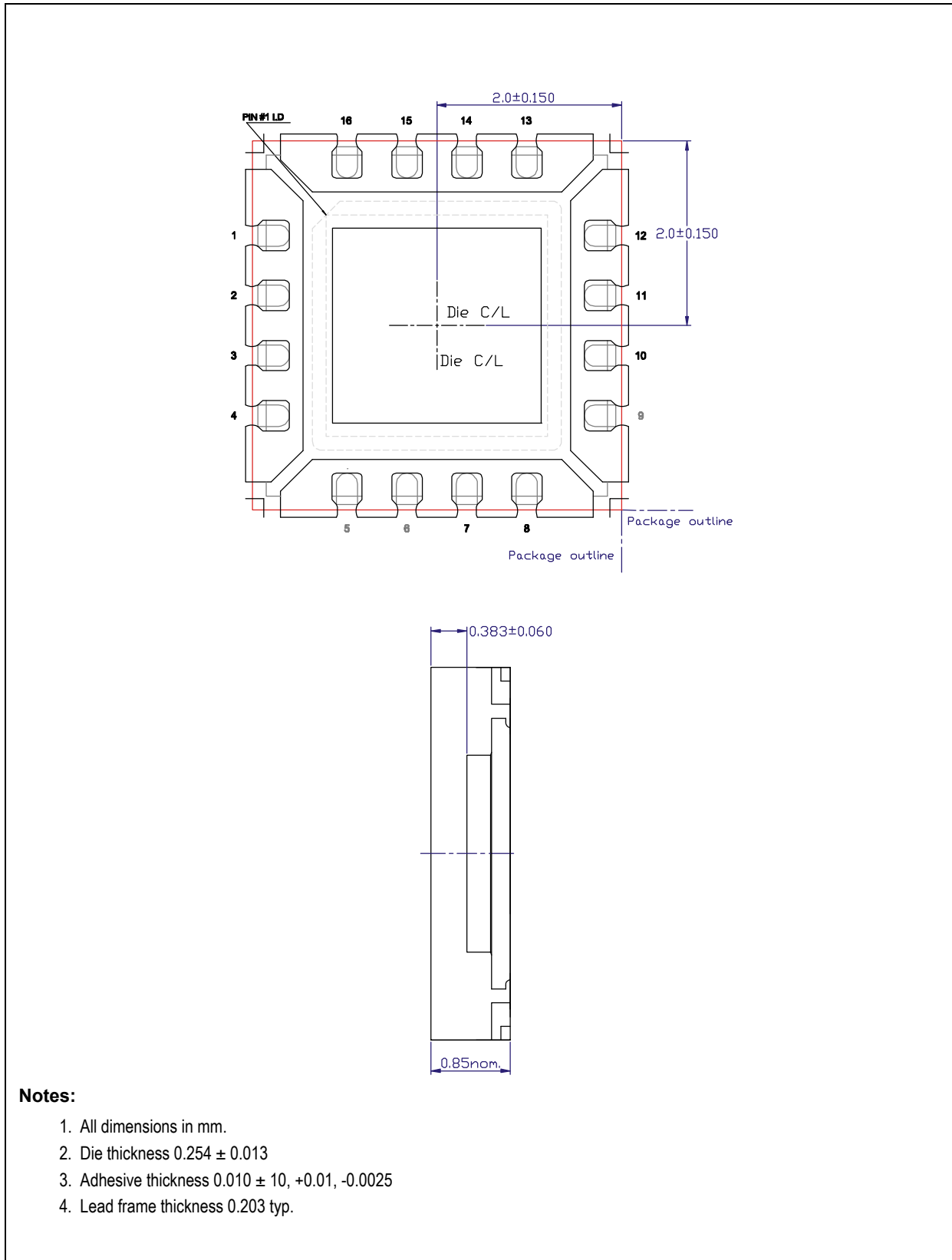



Revision History

Revision	Date	Owner	Description
1.0	23 Mar, 2010	jja	Initial revision of public release version
1.1	8 Jun, 2010	jlu	Updated Pin Descriptions (pin 16), Typical Application , SPI Connection to the Host μC , Figure 3 , Figure 13 , Figure 14 , Figure 15 .
1.11	3 Nov, 2010	agt	Updated Absolute Maximum Ratings , System Parameters , Pin Descriptions , Power Supply Filter , Table 9 , SPI Connection to the Host μC , Package Drawings and Markings .
1.12	3 Nov, 2011	mub	Updated operating temperature range.
1.13	28 Dec, 2011	rei	Updated Figure 3 , Table 9 and package drawings.
1.14	11 Jul, 2012		Updated Alarm LO / HI info in Table 9 .
1.15	16 Oct, 2012	ekno	Updated Figure 1 , Section 4 , Section 7.2.4 , Table 16 ; Added Error Status Command , Figure 19 , Section 8.1.4
1.16	05 Feb, 2013		Correction of error status register and alarm bits, updated marking.
	21 Feb, 2013		Updated Table 4 , Table 14 , Table 16

Note: Typos may not be explicitly mentioned under revision history.



10 Ordering Information

The devices are available as the standard products shown in [Table 17](#).

Table 17. Ordering Information

Ordering Code	Description	Delivery Form	Package
AS5055 EQFT	12-bit low power magnetic rotary encoder	Tape & Reel	16-pin QFN (4x4x0.85 mm)

Note: All products are RoHS compliant and ams green.
Buy our products or get free samples online at www.ams.com/ICdirect

Technical Support is available at www.ams.com/Technical-Support

For further information and requests, email us at sales@ams.com
(or) find your local distributor at www.ams.com/distributor



Copyrights

Copyright © 1997-2013, ams AG, Tobelbaderstrasse 30, 8141 Unterpemstaetten, Austria-Europe. Trademarks Registered ®. All rights reserved. The material herein may not be reproduced, adapted, merged, translated, stored, or used without the prior written consent of the copyright owner.

All products and companies mentioned are trademarks or registered trademarks of their respective companies.

Disclaimer

Devices sold by ams AG are covered by the warranty and patent indemnification provisions appearing in its Term of Sale. ams AG makes no warranty, express, statutory, implied, or by description regarding the information set forth herein or regarding the freedom of the described devices from patent infringement. ams AG reserves the right to change specifications and prices at any time and without notice. Therefore, prior to designing this product into a system, it is necessary to check with ams AG for current information. This product is intended for use in normal commercial applications. Applications requiring extended temperature range, unusual environmental requirements, or high reliability applications, such as military, medical life-support or life-sustaining equipment are specifically not recommended without additional processing by ams AG for each application. For shipments of less than 100 parts the manufacturing flow might show deviations from the standard production flow, such as test flow or test location.

The information furnished here by ams AG is believed to be correct and accurate. However, ams AG shall not be liable to recipient or any third party for any damages, including but not limited to personal injury, property damage, loss of profits, loss of use, interruption of business or indirect, special, incidental or consequential damages, of any kind, in connection with or arising out of the furnishing, performance or use of the technical data herein. No obligation or liability to recipient or any third party shall arise or flow out of ams AG rendering of technical or other services.



Contact Information

Headquarters

ams AG
Tobelbaderstrasse 30
A-8141 Unterpemstaetten, Austria

Tel : +43 (0) 3136 500 0
Fax : +43 (0) 3136 525 01

For Sales Offices, Distributors and Representatives, please visit:

<http://www.ams.com/contact>