

35A Synchronous Step Down COT Controller

ABSOLUTE MAXIMUM RATINGS

These are stress ratings only and functional operation of the device at these ratings or any other above those indicated in the operation sections of the specifications below is not implied. Exposure to absolute maximum rating conditions for extended periods of time may affect reliability.

V_{IN}	-0.3V to 28V
V_{CC}	-0.3V to 6.0V
BST	-0.3V to 34V ²
BST-SW	-0.3V to 6V
SW, ILIM	-5V to 28V ^{1,2}
GH.....	-0.3V to BST+0.3V
GH-SW.....	-0.3V to 6V
ALL other pins.....	-0.3V to $V_{CC}+0.3V$
Storage temperature	-65°C to 150°C
Junction temperature.....	150°C
Power dissipation	Internally Limited
Lead temperature (Soldering, 10 sec)	300°C
ESD rating (HBM - Human Body Model).....	2kV

OPERATING RATINGS

V_{IN}	-0.3V to 22V
V_{CC}	-0.3V to 5.5V
SW, ILIM	-1V to 26V ¹
PGOOD, VCC, TON, SS, EN, GL, FB	-0.3V to 5.5V
Switching frequency	200kHz - 800kHz ³
Junction temperature range	-40°C to 125°C

Note 1: SW pin's minimum DC range is -1V, transient is -5V for less than 50ns

Note 2: No external voltage applied

Note 3: Recommended

ELECTRICAL SPECIFICATIONS

Specifications are for the operating junction temperature of $T_J = 25^\circ\text{C}$ only; limits applying over the full operating junction temperature range are denoted by a "•". Minimum and maximum limits are guaranteed through test, design, or statistical correlation. Typical values represent the most likely parametric norm at $T_J = 25^\circ\text{C}$, and are provided for reference purposes only. Unless otherwise indicated, $V_{IN} = 12V$, BST = VCC, SW = GND = PGND = 0V, CGH = CGL = 3.3nF.

Parameter	Min.	Typ.	Max.	Units	Conditions
Power Supply Characteristics					
V_{IN} , input voltage range	5	12	22	V	• VCC regulating • VCC tied to V_{IN}
	4.5	5.0	5.5		
I_{VIN} , V_{IN} supply current		0.7	2	mA	• Not switching, $V_{IN} = 12V$, VFB = 0.7V
I_{VCC} , VCC quiescent current		0.7	2	mA	• Not switching, $V_{CC} = V_{IN} = 5V$, VFB = 0.7V
I_{VIN} , V_{IN} supply current		11		mA	f = 300kHz, RON = 108.8k, VFB = 0.58V
I_{OFF} , shutdown current		0.1		µA	Enable = 0V, $V_{IN} = 12V$
Enable and Under-Voltage Lock-Out UVLO					
V_{IH_EN} , EN pin rising threshold	1.8	1.9	2.0	V	•
V_{EN_HYS} , EN pin hysteresis		50		mV	
V_{IH_EN} , EN pin rising threshold for DCM/CCM operation	2.9	3.0	3.1	V	•
V_{EN_HYS} , EN pin hysteresis		100		mV	
VCC UVLO start threshold, rising edge	4.00	4.25	4.50	V	•
VCC UVLO hysteresis		200		mV	
Reference Voltage					
V_{REF} , reference voltage	0.597	0.600	0.603	V	$V_{IN} = 5V-22V \rightarrow$ VCC regulating
	0.596		0.604	V	$V_{IN} = 4.5V-5.5V \rightarrow$ tie VCC to V_{IN}
	0.594	0.600	0.606	V	• $V_{IN} = 5V-22V \rightarrow$ VCC regulating, $V_{IN} = 4.5V-5.5V \rightarrow$ tie VCC to V_{IN}
DC line regulation		±0.1		%	CCM operation, closed loop, applies to any C_{OUT}
DC load regulation		±0.25		%	CCM operation, closed loop, applies to any C_{OUT}

35A Synchronous Step Down COT Controller

Parameter	Min.	Typ.	Max.	Units	Conditions
Programmable Constant On-Time					
On-time 1	1855	2182	2509	ns	• RON = 141.2kΩ, VIN = 22V
f corresponding to on-time 1	217	250	294	kHz	VIN = 22V, VOUT = 12V
Minimum programmable on-time		109		ns	RON = 7.059kΩ, VIN = 22V
On-time 2	170	200	230	ns	• RON = 7.059kΩ, VIN = 12V
f corresponding to on-time 2	1618	1375	1196	kHz	VOUT = 3.3V
f corresponding to on-time 2	490	417	362	kHz	VOUT = 1.0V
On-time 3	391	460	529	ns	• RON = 16.235kΩ, VIN = 12V
Minimum off-time		250	350	ns	•
Diode Emulation Mode					
Zero crossing threshold	-4	-1		mV	DC value measured during test
Soft-Start					
SS charge current	-14	-10	-6	μA	•
SS discharge current	1			mA	• Fault present
VCC Linear Regulator (VCC should be tied to VIN, for 4.5V ≤ VIN ≤ 5.5V)					
VCC output voltage	4.8	5.0	5.2	V	• VIN = 6V to 22V, Iload = 0 to 30mA
	4.51	4.7			• VIN = 5V, Iload = 0 to 20mA
Dropout voltage		200	490	mV	• IVCC = 30mA
Power Good Output					
Power Good threshold	-10	-7.5	-5	%	
Power Good hysteresis		2	4	%	
Power Good sink current	1			mA	
Protection: OCP, OTP, Short-circuit					
Hiccup timeout		110		ms	
ILIM pin source current	45	50	55	μA	
ILIM current temperature coefficient		0.4		%/°C	
OCP comparator offset	-8	0	+8	mV	•
Current limit blanking		100		ns	GL rising > 1V
Thermal shutdown threshold ¹		150		°C	Rising temperature
Thermal hysteresis ¹		15		°C	
VSCTH feedback pin short-circuit threshold	50	60	70	%	• Percent of VREF, short circuit is active after PGOOD is up
Output Gate drivers					
GH pull-down resistance		1.35	2.0	Ω	IGH = 200mA
GH pull-up resistance		1.8	2.8	Ω	IGH = 200mA
GL pull-down resistance		1.35	1.9	Ω	IGL = 200mA
GL pull-up resistance		1.7	2.7	Ω	IGL = 200mA
GH and GL pull-down resistance		50	---	kΩ	
GH and GL rise time		35	50	ns	10% to 90%
GH and GL fall time		30	40	ns	90% to 10%
GL to GH non-overlap time	20	30	60	ns	Measured GL falling edge = 1V to GH rising edge = 1V, BST = VCC, SW = 0V
GH to GL non-overlap time	15	20	40	ns	Measured GH falling edge = 1V to GL rising edge = 1V

Note 1: Guaranteed by design

BLOCK DIAGRAM

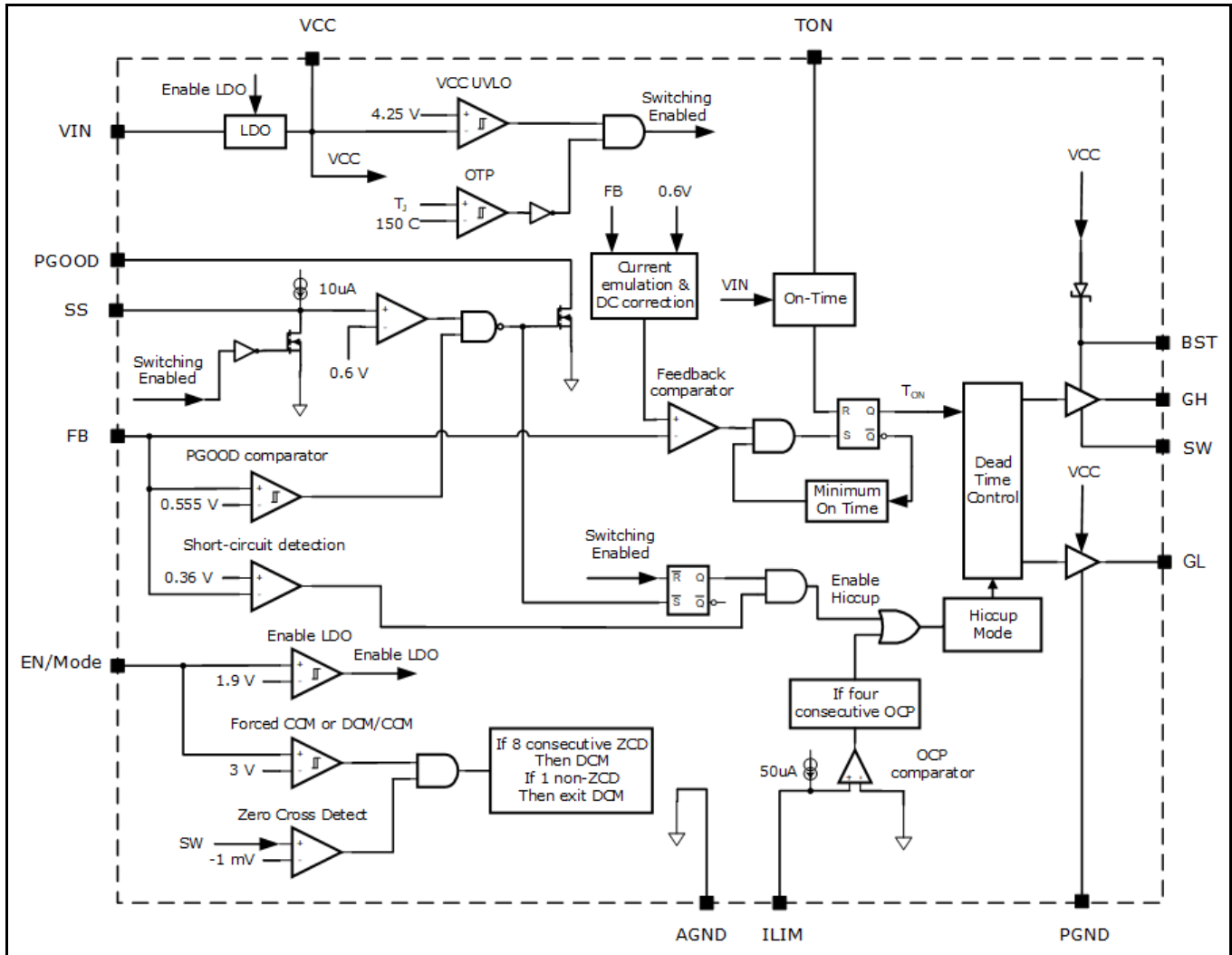

Fig. 2: XRP6141 Block Diagram

PIN ASSIGNMENT

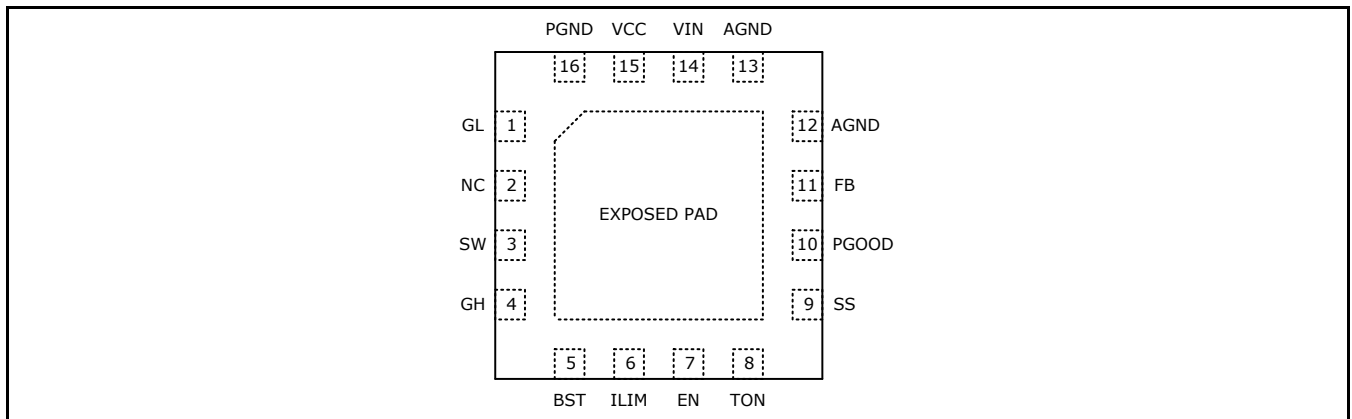

Fig. 3: XRP6141 Pin Assignment

35A Synchronous Step Down COT Controller
PIN DESCRIPTION

Name	Pin Number	Description
GL	1	Driver output for Low-side N-channel synchronous MOSFET.
NC	2	Internally not connected. Leave this pin floating.
SW	3	Lower supply rail for high-side gate driver GH. Connect this pin to the junction between the two external N-channel MOSFETs.
GH	4	Driver output for high-side N-channel switching MOSFET.
BST	5	High-side driver supply pin. Connect a 0.1 μ F bootstrap capacitor between BST and SW.
ILIM	6	Over-current protection programming. Connect with a resistor to the drain of the low-side MOSFET.
EN/MODE	7	Precision enable pin. Pulling this pin above 1.9V will turn the IC on and it will operate in Forced CCM. If the voltage is raised above 3.0V, then the IC will operate in DCM or CCM, depending on load.
TON	8	Constant on-time programming pin. Connect with a resistor to AGND.
SS	9	Soft-start pin. Connect an external capacitor between SS and AGND to program the soft-start rate based on the 10 μ A internal source current.
PGOOD	10	Power-good output. This open-drain output is pulled low when V _{OUT} is outside the regulation.
FB	11	Feedback input to feedback comparator. Connect with a set of resistors to V _{OUT} and GND in order to program V _{OUT} .
AGND	12, 13	Analog ground. Control circuitry of the IC is referenced to this pin.
VIN	14	IC supply input. Provides power to internal LDO.
VCC	15	The output of LDO. For operation using a 5V rail, VCC should be shorted to VIN.
PGND	16	Low side driver ground.
Exposed Pad		Thermal pad for heat dissipation. Connect to AGND with a short trace.

ORDERING INFORMATION⁽¹⁾

Part Number	Operating Temperature Range	Package	Packing Method	Lead-Free
XRP6141ELTR-F	-40°C ≤ T _J ≤ +125°C	3x3mm QFN16	Tape & Reel	Yes ⁽²⁾
XRP6141EVB	XRP6141 Evaluation Board			

NOTES:

1. Refer to www.maxlinear.com/XRP6141 for most up-to-date Ordering Information
2. Visit www.maxlinear.com for additional information on Environmental Rating.

35A Synchronous Step Down COT Controller

TYPICAL PERFORMANCE CHARACTERISTICS

All data taken at $V_{IN} = 12V$, $V_{OUT} = 1.2V$, $f = 300kHz$, $T_A = 25^\circ C$, unless otherwise specified - schematic and BOM from Application Information section of this datasheet.

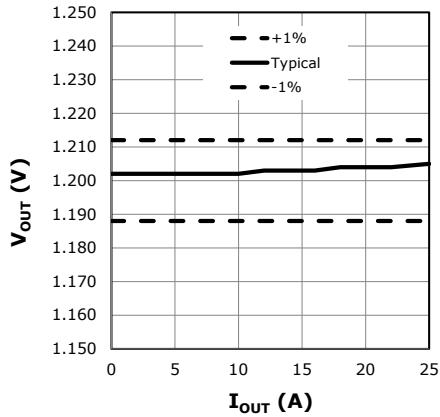

Fig. 4: Load Regulation, $V_{IN} = 12V$

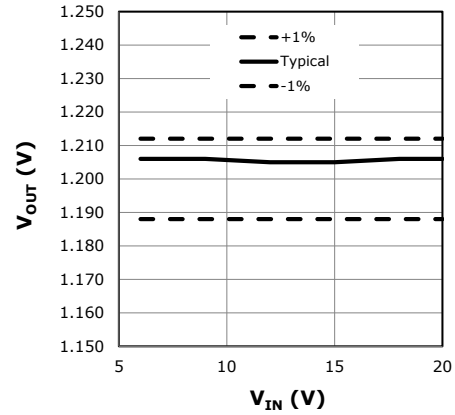

Fig. 5: Line Regulation, $I_{OUT} = 25A$

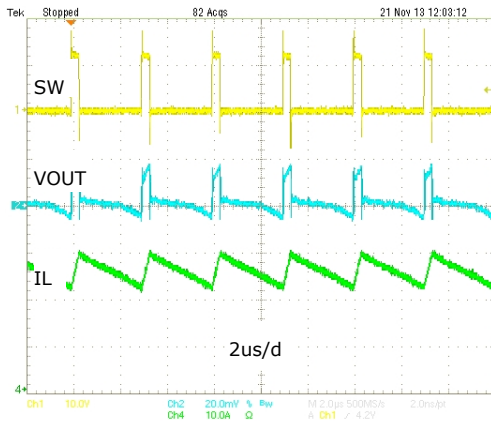

Fig. 6: V_{OUT} Ripple is 22mV at 25A, 12 V_{IN} , 1.2 V_{OUT}

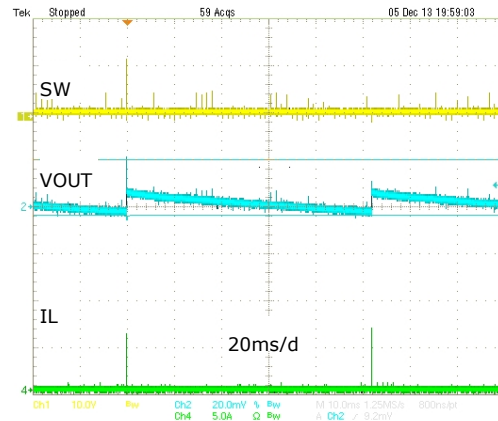

Fig. 7: V_{OUT} Ripple is 22mV at 0A, DCM, 12 V_{IN} , 1.2 V_{OUT}

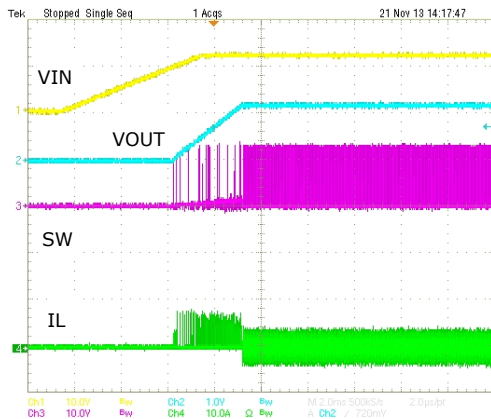

Fig. 8: Powerup, Forced CCM, $I_{OUT} = 0A$

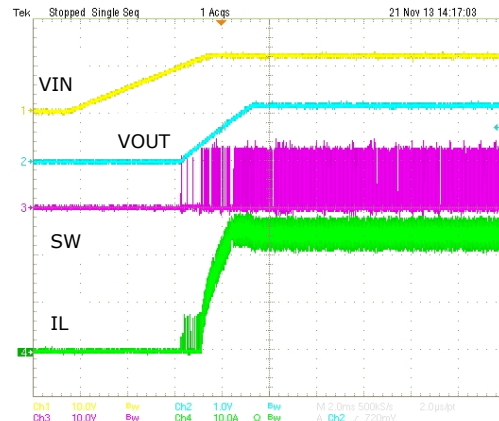

Fig. 9: Powerup, Forced CCM, $I_{OUT} = 25A$

35A Synchronous Step Down COT Controller

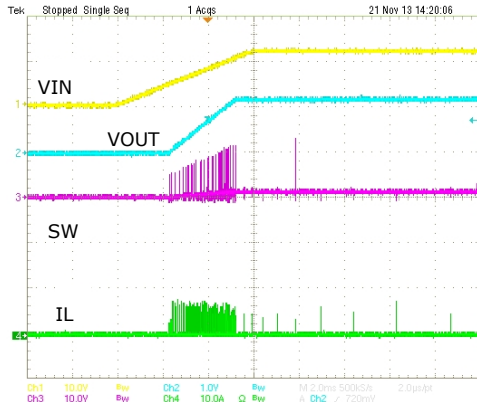

Fig. 10: Powerup, DCM / CCM, $I_{OUT} = 0A$

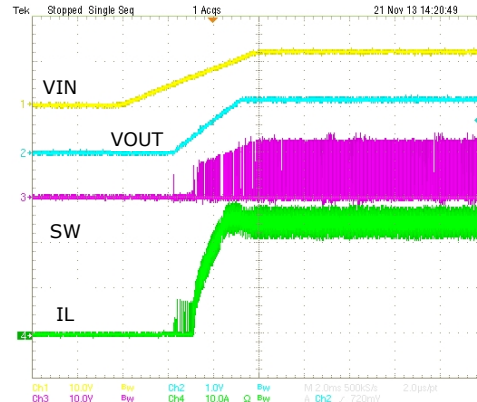

Fig. 11: Powerup, DCM / CCM, $I_{OUT} = 25A$

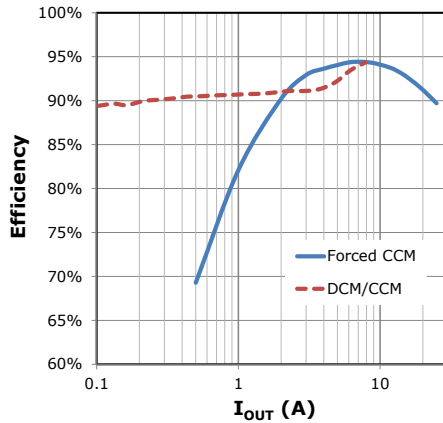

Fig. 12: Efficiency, $5V_{IN}$, $1.8V_{OUT}$, $0.47\mu H$, $300kHz$

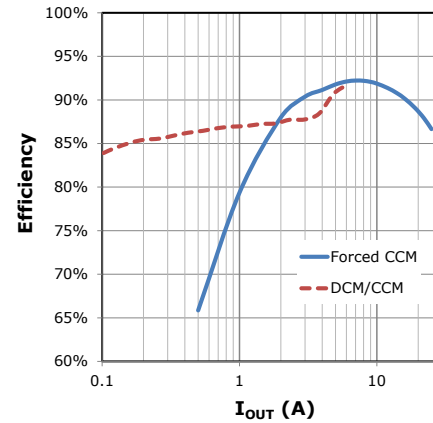

Fig. 13: Efficiency, $5V_{IN}$, $1.2V_{OUT}$, $0.47\mu H$, $300kHz$

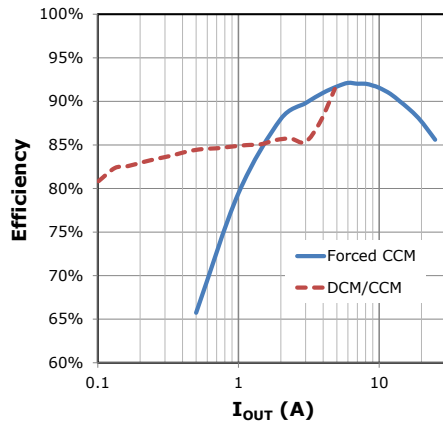

Fig. 14: Efficiency, $5V_{IN}$, $1.0V_{OUT}$, $0.47\mu H$, $300kHz$

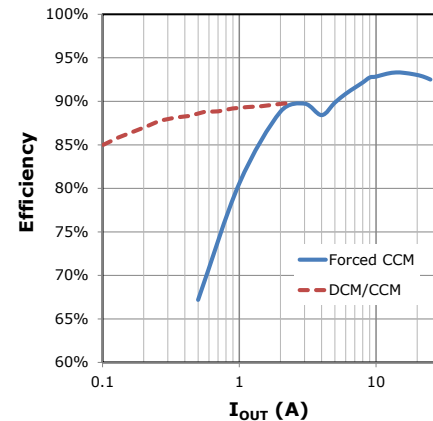

Fig. 15: Efficiency, $12V_{IN}$, $3.3V_{OUT}$, $1\mu H$, $300kHz$

35A Synchronous Step Down COT Controller

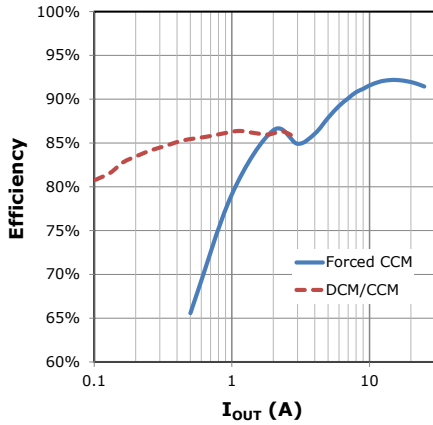

Fig. 16: Efficiency, 12V_{IN}, 2.5V_{OUT}, 1µH, 300kHz

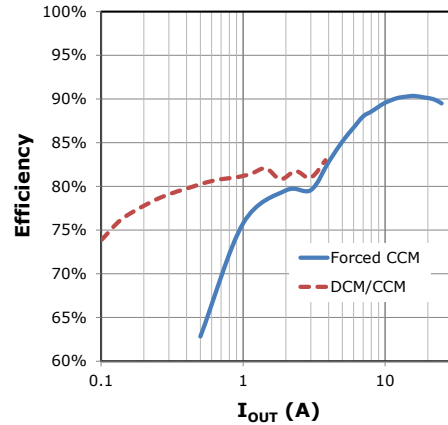

Fig. 17: Efficiency, 12V_{IN}, 1.8V_{OUT}, 1µH, 300kHz

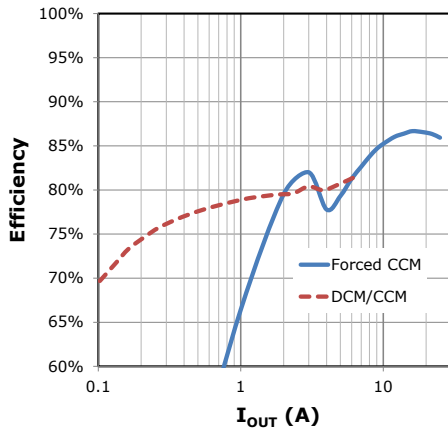

Fig. 18: Efficiency, 12V_{IN}, 1.2V_{OUT}, 0.47µH, 300kHz

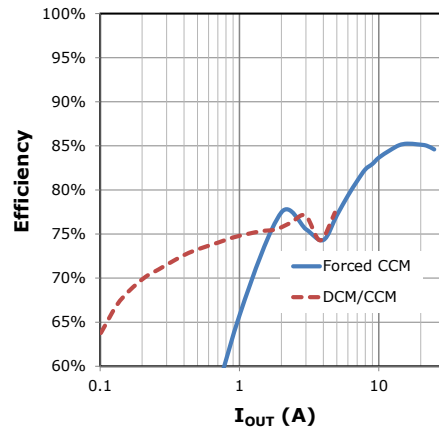

Fig. 19: Efficiency, 12V_{IN}, 1.0V_{OUT}, 0.47µH, 300kHz

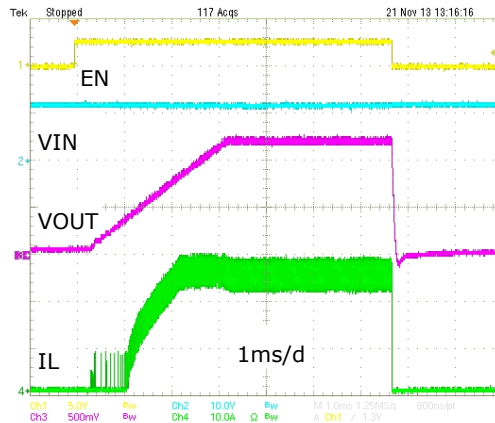

Fig. 20: Enable Turn On / Turn Off, 12V_{IN}, 1.2V_{OUT}, 25A

35A Synchronous Step Down COT Controller

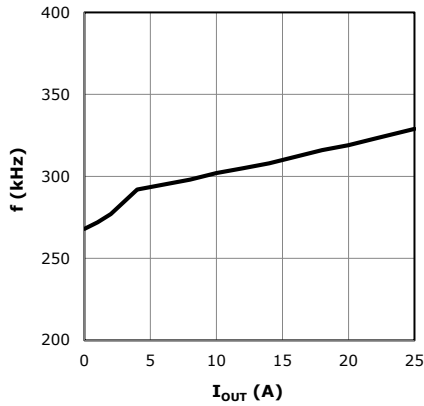

Fig. 22: Frequency versus I_{OUT}, Forced CCM

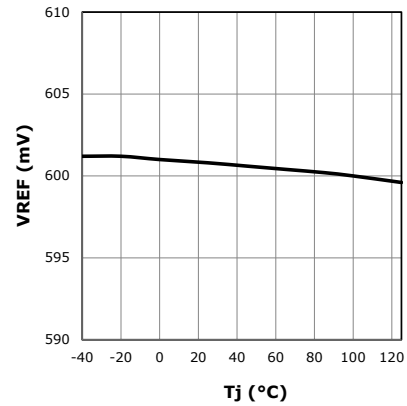

Fig. 23: VREF versus Temperature

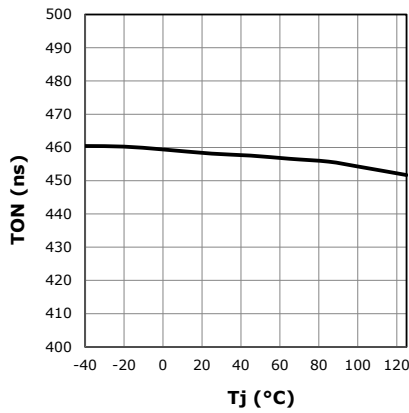

Fig. 24: On-Time versus Temperature

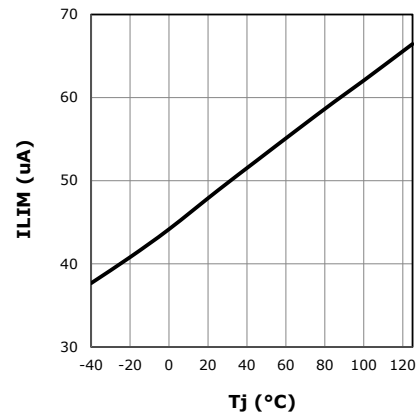

Fig. 25: ILIM versus Temperature

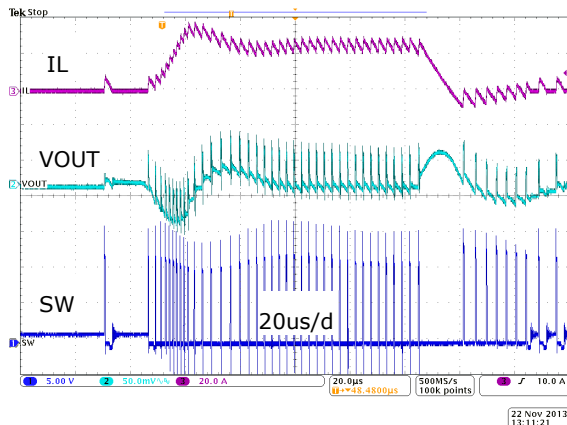

Fig. 26: Load Step, DCM/CCM, 0A-25A-0A

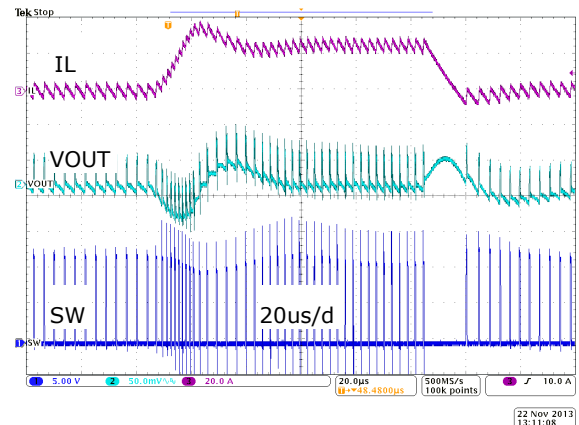

Fig. 27: Load Step, Forced CCM, 0A-25A-0A

35A Synchronous Step Down COT Controller

DETAILED OPERATION

XRP6141 is a synchronous step-down, proprietary emulated, current-mode Constant On-Time (COT) controller. The on-time, which is programmed via RON, is inversely proportional to V_{IN} and maintains a nearly constant frequency. The emulated current-mode control allows the use of ceramic output capacitors.

Each switching cycle begins with the GH signal turning the high-side (switching) FET for a pre-programmed time. At the end of the on-time, the high-side FET is turned off and the low-side (synchronous) FET is turned on for a preset minimum time (250ns nominal). This parameter is termed Minimum Off-Time. After the Minimum Off-Time, the voltage at the feedback pin FB is compared to an internal voltage ramp at the feedback comparator. When V_{FB} drops below the ramp voltage, the high-side FET is turned on and the cycle repeats. This voltage ramp constitutes an emulated current ramp and makes possible the use of ceramic capacitors, in addition to other capacitor types, for output filtering.

ENABLE/MODE INPUT (EN/MODE)

The EN/MODE pin accepts a tri-level signal that is used to control turn on and off. It also selects between two modes of operation: 'Forced CCM' and 'DCM / CCM'. If EN is pulled below 1.9V, the controller shuts down. A voltage between 1.9V and 3.0V selects the Forced CCM Mode, which will run the converter in continuous conduction at all times. A voltage higher than 3.0V selects the DCM / CCM Mode, which will run the converter in discontinuous conduction at light loads.

Selecting the Forced CCM Mode

In order to set the controller to operate in Forced CCM, a voltage between 1.9V and 3.0V must be applied to the EN/MODE pin. This can be achieved with an external control signal that meets the above voltage requirement. Where an external control is not available, the EN/MODE can be derived from V_{IN} . If V_{IN} is well regulated, use a resistor divider and set the voltage to 2.5V. If V_{IN} varies over a wide range, the circuit shown in Figure 28 can be used to generate the required voltage. Note that at V_{IN} of 5.5V to 22V, the nominal Zener voltage is 4.0V to 5.0V respectively. Therefore, for V_{IN} in the range of 5.5V to 22V, the circuit shown in Figure 28 will generate voltage at the EN/MODE pin required for Forced CCM.

Selecting the DCM/CCM Mode

In order to set the controller operation to DCM / CCM, a voltage between 3.1V and 5.5V must be applied to the EN/MODE pin. If an external control signal is available, it can be directly connected to the EN/MODE pin. In applications where an external control signal is not available, the EN/MODE input can be derived from V_{IN} . If V_{IN} is well regulated, use a resistor divider and set the voltage to 4V. If V_{IN} varies over a wide range, the circuit shown in Figure 29 can be used to generate the required voltage.

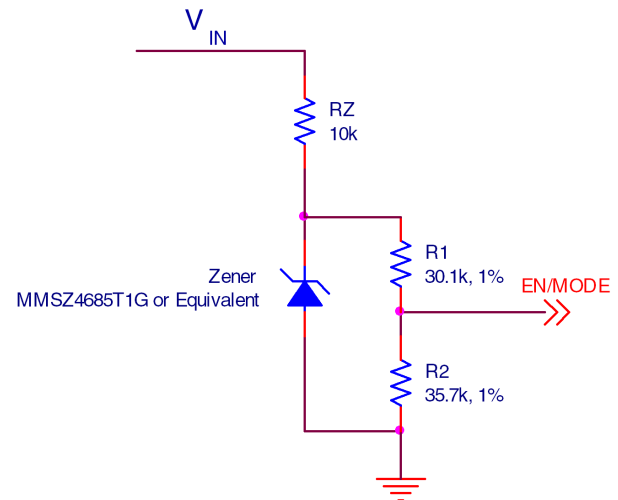

Figure 28. Selecting Forced CCM by Deriving EN/MODE from V_{IN}

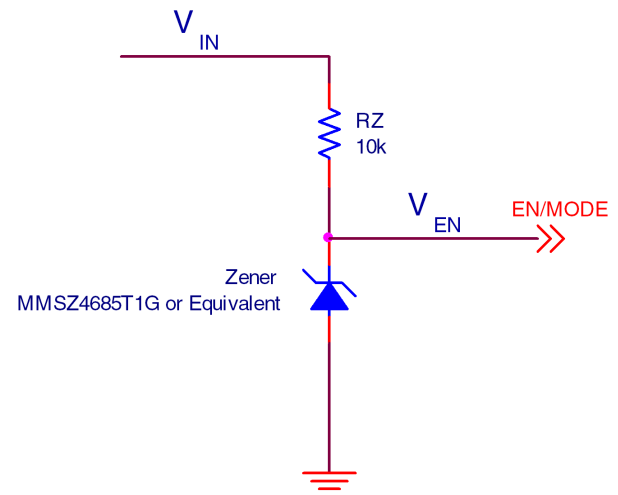

Figure 29. Selecting DCM / CCM by Deriving EN/MODE from V_{IN}

PROGRAMMING THE ON-TIME

The on-time T_{ON} is programmed via resistor RON according to following equation:

$$T_{ON} = \frac{(3.4E - 10) \times R_{ON}}{V_{IN}}$$

The required T_{ON} for a given application is calculated from:

$$T_{ON} = \frac{V_{OUT}}{V_{IN} \times f}$$

35A Synchronous Step Down COT Controller

Note that switching frequency f will increase somewhat, as a function of increasing load current and increasing losses (see Figure 22).

OVER-CURRENT PROTECTION (OCP)

If load current exceeds the programmed over-current I_{OCP} for four consecutive switching cycles, then the IC enters hiccup mode of operation. In hiccup, the MOSFET gates are turned off for 110ms (hiccup timeout). Following the hiccup timeout, a soft-start is attempted. If OCP persists, hiccup timeout will repeat. The IC will remain in hiccup mode until load current is reduced below the programmed I_{OCP} . In order to program over-current protection, use the following equation:

$$RLIM = \frac{(I_{OCP} \times RDS) + 8mV}{ILIM}$$

Where:

$RLIM$ is resistor value for programming I_{OCP}

I_{OCP} is the over-current value to be programmed

RDS is the MOSFET rated on resistance

8mV is the OCP comparator offset

$ILIM$ is the internal current that generates the necessary OCP comparator threshold (use 45 μ A)

Note that $ILIM$ has a positive temperature coefficient of 0.4%/°C. This is meant to roughly match and compensate for positive temperature coefficient of the synchronous FET. In order for this feature to be effective, the temperature rise of the IC should approximately match the temperature rise of the FET.

SHORT-CIRCUIT PROTECTION (SCP)

If the output voltage drops below 60% of its programmed value, the IC will enter hiccup mode. Hiccup will persist until the short-circuit is removed. The SCP circuit becomes active after PGOOD asserts high.

OVER-TEMPERATURE PROTECTION (OTP)

OTP triggers at a nominal die temperature of 150°C. The gate of switching FET and synchronous FET are turned off. When die temperature cools down to 135°C, soft-start is initiated and operation resumes.

PROGRAMMING THE OUTPUT VOLTAGE

Use an external voltage divider as shown in Figure 1 to program the output voltage V_{OUT} .

$$R1 = R2 \times \left(\frac{V_{OUT}}{0.6} - 1 \right)$$

The $R2$ recommended range is 2k Ω to 10k Ω .

PROGRAMMING THE SOFT-START

Place a capacitor CSS between the SS and GND pins to program the soft-start. In order to program a soft-start time of TSS, calculate the required capacitance CSS from the following equation:

$$CSS = TSS \times \frac{10\mu A}{0.6V}$$

FEED-FORWARD CAPACITOR (C_{FF})

A feed-forward capacitor (C_{FF}) may be necessary depending on the Equivalent Series Resistance (ESR) of C_{OUT} . If only ceramic output capacitors are used, then a C_{FF} is necessary. Calculate C_{FF} from:

$$CFF = \frac{1}{2 \times \pi \times R1 \times 7 \times f_{LC}}$$

where:

$R1$ is the resistor that C_{FF} is placed in parallel with

f_{LC} is the frequency of the output filter double pole

f_{LC} must be less than 15kHz when using ceramic C_{OUT} . If necessary, increase C_{OUT} and/or L in order to meet this constraint.

When using capacitors with higher ESR such as the Panasonic TPE series, a C_{FF} is not required provided the following conditions are met:

1. The frequency of the output LC double pole f_{LC} should be less than 10kHz.
2. The frequency of ESR zero $f_{ZERO,ESR}$ should be at least five times larger than f_{LC} .

Note that if $f_{ZERO,ESR}$ is less than 5 x f_{LC} , then it is recommended to set the f_{LC} at less than 2kHz. C_{FF} is still not required.

FEED-FORWARD RESISTOR (R_{FF})

Poor PCB layout and/or extremely fast switching FETs can cause switching noise at the output and may couple to the FB pin via C_{FF} . Excessive noise at FB will cause poor load regulation. To solve this problem, place a resistor R_{FF} in series with C_{FF} . A R_{FF} value up to 2% of $R1$ is acceptable.

MAXIMUM ALLOWABLE VOLTAGE RIPPLE AT FB PIN

Note that the steady-state voltage ripple at feedback pin ($V_{FB,RIPPLE}$) must not exceed 50mV in order for the controller to function correctly. If $V_{FB,RIPPLE}$ is larger than 50mV, then C_{OUT} should be increased as necessary in order to keep the $V_{FB,RIPPLE}$ below 50mV.

35A Synchronous Step Down COT Controller

Applications Circuit

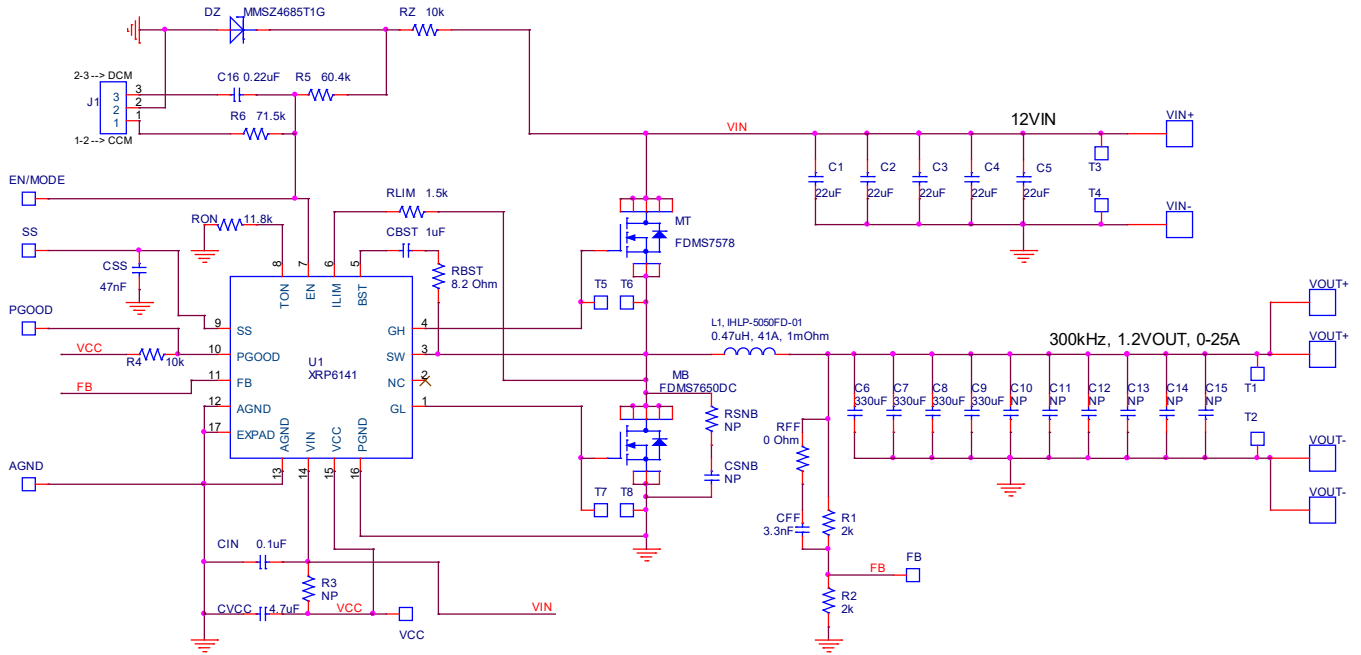

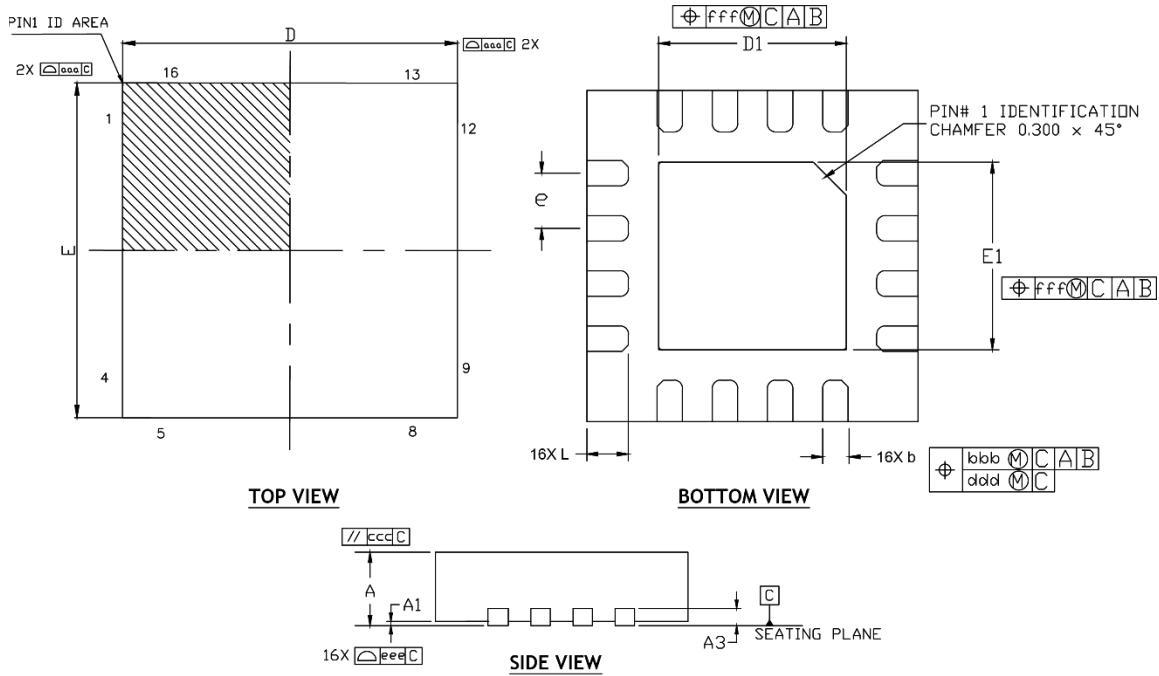
35A Synchronous Step Down COT Controller
MECHANICAL DIMENSIONS
16 PIN 3X3 QFN

DIMENSION TABLE			
SYMBOL	MIN	NOM	MAX
A	0.80	0.90	1.00
A1	0.00	0.02	0.05
A3	0.20Ref		
b	0.18	0.25	0.30
D	3.00 BSC		
E	3.00 BSC		
e	0.50 BSC		
D1	1.50	1.65	1.80
E1	1.50	1.65	1.80
L	0.20	0.30	0.40
K	0.20	-	-
aaa		0.15	
bbb		0.10	
ccc		0.10	
ddd		0.05	
eee		0.08	
fff		0.10	
N		16	

TERMINAL DETAILS

- ALL DIMENSIONS ARE IN MILLIMETERS.
- DIMENSIONS AND TOLERANCE PER JEDEC MO-220.

Drawing No.: POD- 00000138

Revision: A

RECOMMENDED LAND PATTERN AND STENCIL

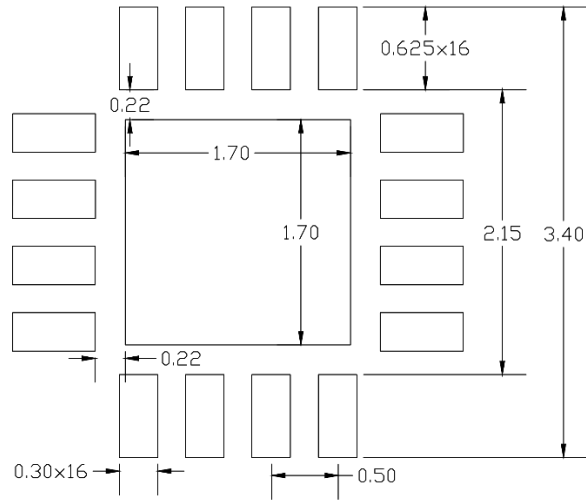

TYPICAL RECOMMENDED LAND PATTERN

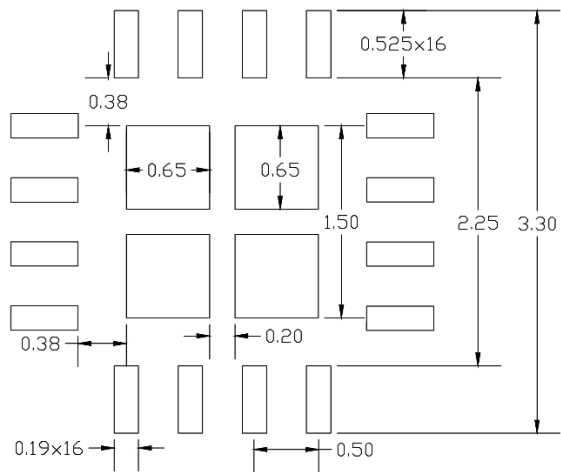

TYPICAL RECOMMENDED STENCIL

Drawing No.: POD- 00000138

Revision: A

REVISION HISTORY

Revision	Date	Description
1.0.0	12/16/2013	Initial release
1.0.1	12/20/2013	Specification improvement
2.0.0	7/31/2005	Modified Functional Block Diagram, Application Circuit, Feed-Forward Capacitor; added "Selecting the Forced CCM Mode", "Selecting the DCM/CCM Mode", "Feed-Forward Resistor", "Maximum Allowable Voltage Ripple at FB Pin" sections.
2.0.1	11/23/2015	Change VCC Linear Regulator Dropout Voltage from 200mV min and 300mV typ to 200mV typ.
2.0.2	5/24/2018	Update to MaxLinear logo. Update format and Ordering Information table. Added Revision History.
2.0.3	10/17/2019	Correct block diagram by changing the input gate to the Hiccup Mode block from an AND gate to an OR gate. Update ordering information.

**Corporate Headquarters:**

5966 La Place Court
Suite 100
Carlsbad, CA 92008
Tel.: +1 (760) 692-0711
Fax: +1 (760) 444-8598

www.maxlinear.com

The content of this document is furnished for informational use only, is subject to change without notice, and should not be construed as a commitment by MaxLinear, Inc. MaxLinear, Inc. assumes no responsibility or liability for any errors or inaccuracies that may appear in the informational content contained in this guide. Complying with all applicable copyright laws is the responsibility of the user. Without limiting the rights under copyright, no part of this document may be reproduced into, stored in, or introduced into a retrieval system, or transmitted in any form or by any means (electronic, mechanical, photocopying, recording, or otherwise), or for any purpose, without the express written permission of MaxLinear, Inc.

MaxLinear, Inc. does not recommend the use of any of its products in life support applications where the failure or malfunction of the product can reasonably be expected to cause failure of the life support system or to significantly affect its safety or effectiveness. Products are not authorized for use in such applications unless MaxLinear, Inc. receives, in writing, assurances to its satisfaction that: (a) the risk of injury or damage has been minimized; (b) the user assumes all such risks; (c) potential liability of MaxLinear, Inc. is adequately protected under the circumstances.

MaxLinear, Inc. may have patents, patent applications, trademarks, copyrights, or other intellectual property rights covering subject matter in this document. Except as expressly provided in any written license agreement from MaxLinear, Inc., the furnishing of this document does not give you any license to these patents, trademarks, copyrights, or other intellectual property.

MaxLinear, the MaxLinear logo, and any MaxLinear trademarks, MxL, Full-Spectrum Capture, FSC, G.now, AirPHY and the MaxLinear logo are all on the products sold, are all trademarks of MaxLinear, Inc. or one of MaxLinear's subsidiaries in the U.S.A. and other countries. All rights reserved. Other company trademarks and product names appearing herein are the property of their respective owners.