

4-Bit binary counters

54F161A, 54F163A

PIN CONFIGURATION

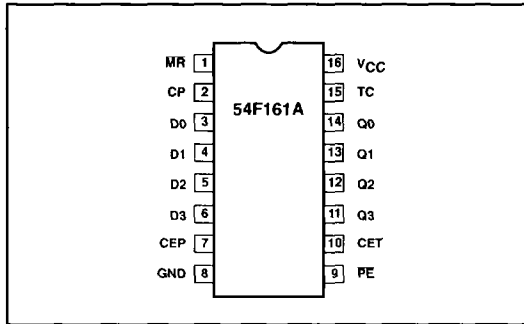

LOGIC SYMBOL

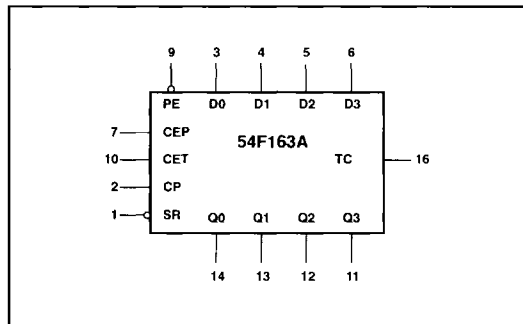
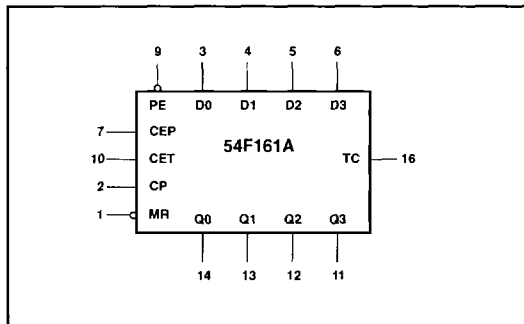
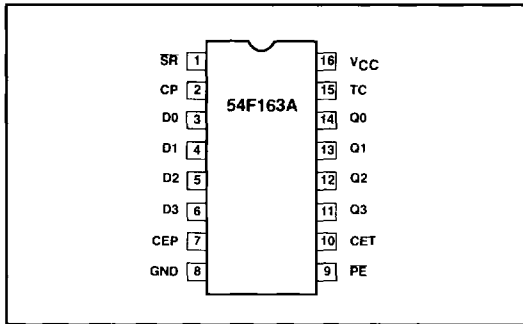

LLCC LEAD CONFIGURATION

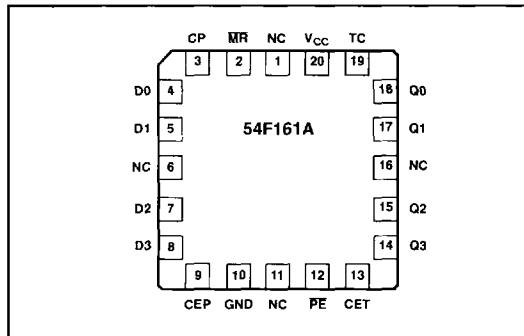

LLCC LEAD CONFIGURATION

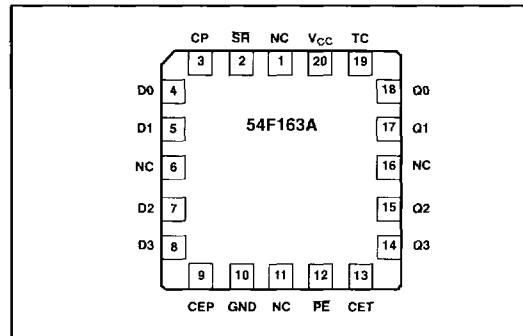

4-Bit binary counters

54F161A, 54F163A

STATE DIAGRAM

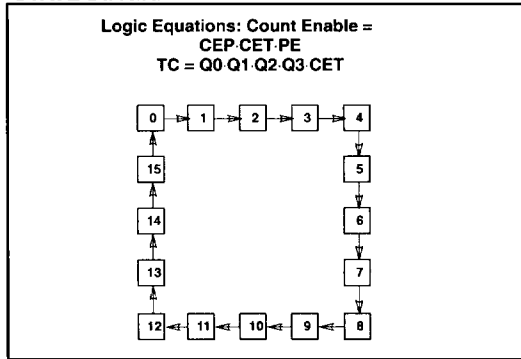

LOGIC DIAGRAM

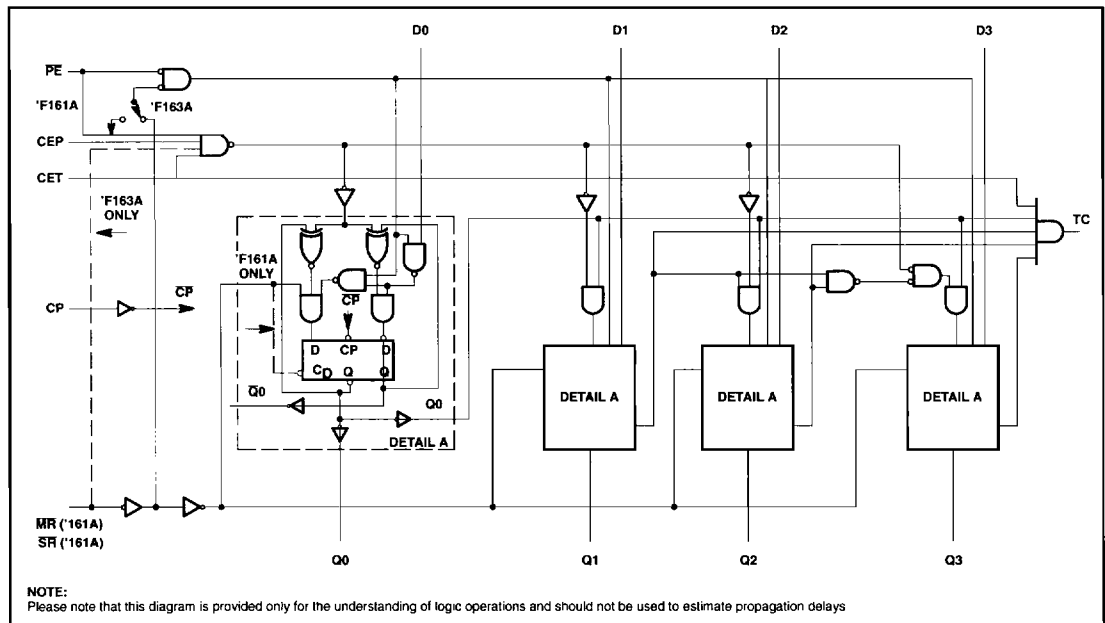

MODE SELECT — FUNCTION TABLE, 54F161A

OPERATING MODE	INPUTS					OUTPUTS		
	MR	CP	CEP	CET	PE	D _n	Q _n	TC
Reset (clear)	L	X	X	X	X	X	L	L
Parallel load	H	↑	X	X	l	l	L	L
	H	↑	X	X	l	h	H	(1)
Count	H	↑	h	h	h	X	count	(1)
Hold (do nothing)	H	X	l	X	h	X	q _n	(1)
	H	X	X	X	h	X	q _n	L

4-Bit binary counters

54F161A, 54F163A

MODE SELECT — FUNCTION TABLE, 54F163A

OPERATING MODE	INPUTS						OUTPUTS	
	SR	CP	CEP	CET	PE	D _n	Q _n	TC
Reset (clear)	l	↑	X	X	X	X	L	L
Parallel load	h	↑	X	X	l	l	L	L
	h	↑	X	X	l	h	H	(2)
Count	h	↑	h	h	h	X	count	(2)
Hold (do nothing)	h	X	l	X	h	X	q _n	(2)
	h	X	X	l	h	X	q _n	L

H = High voltage level steady state

L = Low voltage level steady state

h = High voltage level one setup time prior to the Low-to-High clock transition

l = Low voltage level one setup time prior to Low-to-High clock transition

X = Don't care

q = Lower case letters indicate the state of the referenced output prior to the Low-to-High clock transition

↑ = Low-to-High clock transition

NOTES:

(1) The TC output is High when CET is High and the counter is at Terminal Count (HHHH for 54F161A)

(2) The TC output is High when CET is High and the counter is at Terminal Count (HHHH for 54F163A)

ABSOLUTE MAXIMUM RATINGS

(Operation beyond the limits set forth in this table may impair the useful life of the device. Unless otherwise noted these limits are over the operating free-air temperature range.)

SYMBOL	PARAMETER	RATING	UNIT
V _{CC}	Supply voltage range	-0.5 to +7.0	V
V _I	Input voltage range	-0.5 to +7.0	V
I _I	Input current range	-30 to +5	mA
V _O	Voltage applied to output in High output state range	-0.5 to +V _{CC}	V
I _O	Current applied to output in Low output state	40	mA
T _{STG}	Storage temperature range	-65 to +150	°C

RECOMMENDED OPERATING CONDITIONS

SYMBOL	PARAMETER	LIMITS			UNIT
		MIN	NOM	MAX	
V _{CC}	Supply voltage	4.5	5.0	5.5	V
V _{IH}	High-level input voltage	2.0			V
V _{IL}	Low-level input voltage			0.8	V
I _{IK}	Input clamp current			-18	mA
I _{OH}	High-level output current			-1.0	mA
I _{OL}	Low-level output current			20.0	ma
T _{amb}	Operating free-air temperature range	-55		+125	°C

4-Bit binary counters

54F161A, 54F163A

DC ELECTRICAL CHARACTERISTICS

(Over recommended operating free-air temperature range unless otherwise noted.)

SYMBOL	PARAMETER		TEST CONDITIONS ¹	LIMITS			UNIT
				MIN	TYP ²	MAX	
V _{OH}	High-level output voltage		V _{CC} = MIN, V _{IL} = MAX, I _{OH} = MAX, V _{IH} = MIN	2.5			V
V _{OL}	Low-level output voltage		V _{CC} = MIN, V _{IL} = MAX, I _{OL} = MAX, V _{IH} = MIN		0.35	0.50	V
V _{IK}	Input clamp voltage		V _{CC} = MIN, I _I = I _{IK}		-0.73	-1.2	V
I _{IH2}	Input current at maximum input voltage		V _{CC} = MAX, V _I = 7.0V			100	μA
I _{IH1}	High-level input current	CET, SR, PE	V _{CC} = MAX, V _I = 2.7V			40	μA
		Other inputs				20	μA
I _{IL}	Low-level input current	CET, SR, PE	V _{CC} = MAX, V _I = 0.5V			-1.2	mA
		Other inputs				-0.6	mA
I _{OS}	Short-circuit output current ³		V _{CC} = MAX	-60		-150	mA
I _{CC}	Supply current ⁴ (total)	I _{CCH}	V _{CC} = MAX			55	mA
		I _{CCL}				55	mA

AC ELECTRICAL CHARACTERISTICS

SYMBOL	PARAMETER	TEST CONDITIONS	LIMITS					UNIT
			T _{amb} = +25°C V _{CC} = +5.0V C _L = 50pF, R _L = 500Ω			T _{amb} = -55°C to +125°C V _{CC} = +5.0V ± 10% C _L = 50pF, R _L = 500Ω		
			MIN	TYP	MAX	MIN	MAX	
f _{MAX}	Maximum clock frequency	Waveform 1	100	120		75 ⁵		MHz
t _{PLH} t _{PHL}	Propagation delay CP to Q _n	Waveform 1 PE = High	2.0 3.5	4.0 7.0	6.5 10.0	2.0 3.5	7.5 11.5	ns ns
t _{PLH} t _{PHL}	Propagation delay CP to Q _n	Waveform 1 PE = Low	2.0 3.0	4.0 6.0	7.0 8.5	2.0 3.0	8.5 10.0	ns ns
t _{PLH} t _{PHL}	Propagation delay CP to TC	Waveform 1	4.0 3.5	10.0 14.0	14.0 16.0	4.0 3.5	16.5 18.5	ns ns
t _{PLH} t _{PHL}	Propagation delay CET to TC	Waveform 2	2.0 2.0	4.5 4.5	7.5 7.5	2.0 2.0	9.0 9.0	ns ns
t _{PHL}	Propagation delay MR to Q _n (54F161A)	Waveform 3	5.5	9.0	12.0	5.5	14.0	ns
t _{PHL}	Propagation delay MR to TC (54F161A)	Waveform 3	4.5		11.5	4.5	14.0	ns

4-Bit binary counters

54F161A, 54F163A

AC SETUP REQUIREMENTS

SYMBOL	PARAMETER	TEST CONDITIONS	LIMITS					UNIT
			T _{amb} = +25°C V _{CC} = +5.0V C _L = 50pF, R _L = 500Ω			T _{amb} = -55°C to +125°C V _{CC} = +5.0V ± 10% C _L = 50pF, R _L = 500Ω		
			MIN	TYP	MAX	MIN	MAX	
t _s (H) t _s (L)	Setup time, High or Low D _n to CP	Waveform 5	5.0 5.0			5.5 5.5	ns ns	
t _h (H) t _h (L)	Hold time, High or Low D _n to CP	Waveform 5	2.0 2.0			2.5 2.5	ns ns	
t _s (H) t _s (L)	Setup time, High or Low PE or SR to CP	Waveform 5 or 6	11.0 8.5			13.5 10.5	ns ns	
t _h (H) t _h (L)	Hold time, High or Low PE or SR to CP	Waveform 5 or 6	2.0 0			2.0 0	ns ns	
t _s (H) t _s (L)	Setup time, High or Low CEP or CET to CP	Waveform 4	11.0 5.0			13.0 6.5	ns ns	
t _h (H) t _h (L)	Hold time, High or Low CEP or CET to CP	Waveform 4	2.0 0			2.0 0	ns ns	
t _w (H) t _w (L)	Clock pulse width (load), High or Low	Waveform 1	6.5 3.5			9.0 4.0	ns ns	
t _w (H) t _w (L)	Clock pulse width (count), High or Low	Waveform 1	6.5 3.5			9.0 4.0	ns ns	
t _w (L)	\overline{MR} pulse width Low (54F161A)	Waveform 3	5.0			9.5	ns	
t _{rec}	Recovery time, \overline{MR} to CP (54F161A)	Waveform 3	6.0			6.0	ns	

NOTES:

- For conditions shown as MIN or MAX, use the appropriate value specified under recommended operating conditions for the applicable type and function table for operating mode.
- All typical values are at V_{CC} = 5V, T_A = 25°C.
- Not more than one output should be shorted at a time. For testing I_{OS}, the use of high-speed test apparatus and/or sample-and-hold techniques are preferable in order to minimize internal heating and more accurately reflect operational values. Otherwise, prolonged shorting of a High output may raise the chip temperature well above normal and thereby cause invalid readings in other parameter tests. In any sequence of parameter tests, I_{OS} tests should be performed last.
- I_{CC} is measured with the outputs left open and by setting the outputs Low for I_{CCL} and again by setting the outputs high for I_{CCH}.
- These parameters are guaranteed, but not tested.
- Pulse width tests are guaranteed as specified, but tested at 7.0ns due to tester limitations.

4-Bit binary counters

54F161A, 54F163A

AC WAVEFORMS

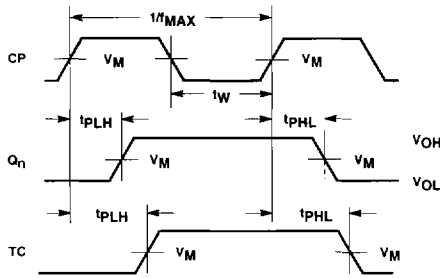

Waveform 1. Clock to Output Delays, Maximum Clock Frequency, and Clock Pulse Width

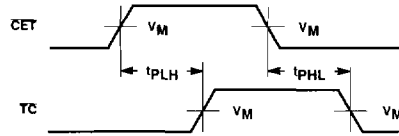

Waveform 2. Propagation Delays CET Input to TC Output

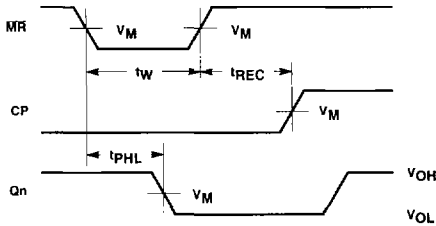

Waveform 3. Master Reset Pulse Width, Master Reset to Output Delay and Master Reset to Clock Recovery Time (54F161A)

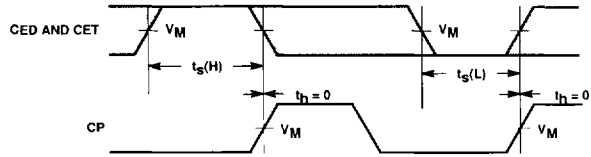

Waveform 4. CEP and CET Setup and Hold Times

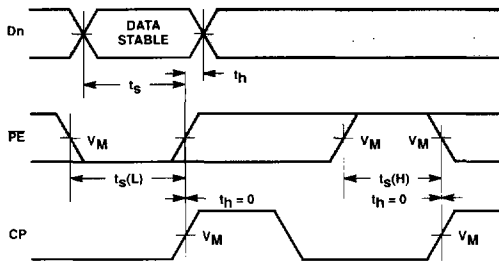

Waveform 5. Parallel Data and Parallel Enable Setup and Hold Times

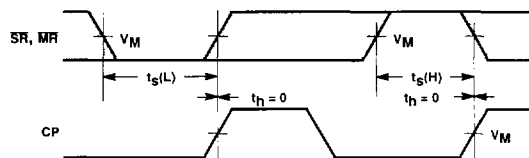

Waveform 6. Synchronous Reset Setup, Pulse Width and Hold Times (54F163A)

NOTE: For all waveforms $V_M = 1.5V$
The shaded areas indicate when the input is permitted to change for predictable output performance

4-Bit binary counters

54F161A, 54F163A

APPLICATION DIAGRAM

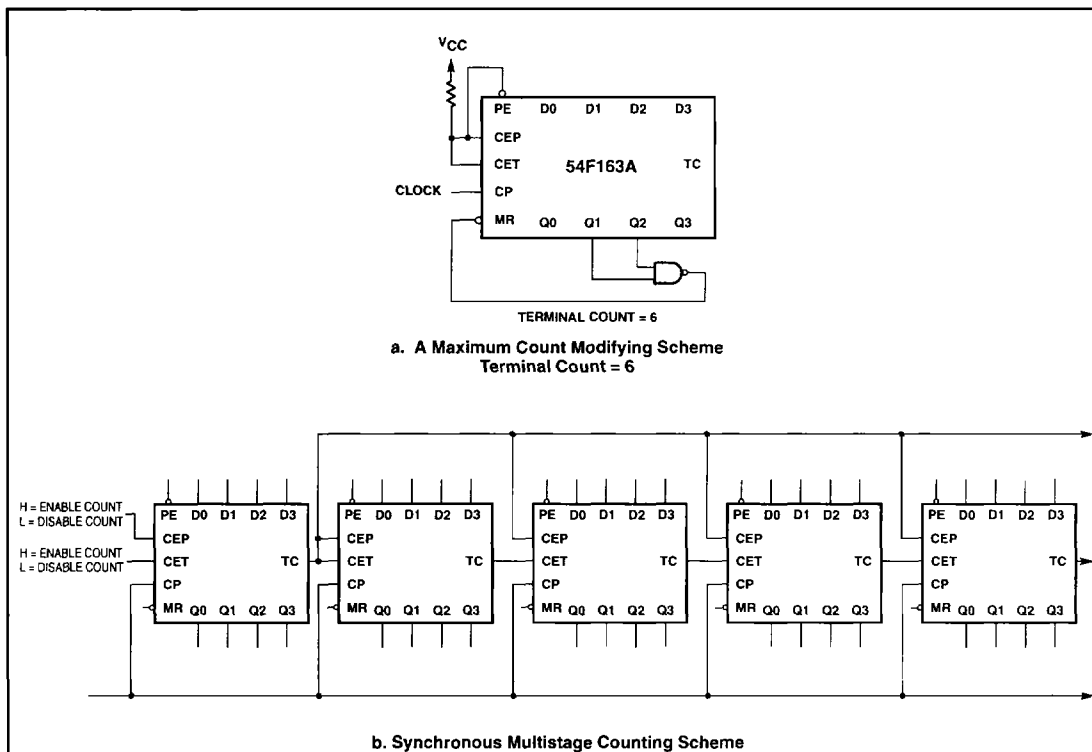

TEST CIRCUIT AND WAVEFORM

Test Circuit for Totem-Pole Outputs

Input Pulse Definition

$V_M = 1.5V$

DEFINITIONS:

- R_L = Load Resistor; see AC Characteristics for value.
- C_L = Load capacitance includes jig and probe capacitance; see AC Characteristics for value.
- R_T = Termination resistance should be equal to Z_{OUT} of pulse generators.
- V_X = Unlocked pins must be held at: $\leq 0.8V$; $\geq 2.7V$ or open per Function Table.

INPUT PULSE CHARACTERISTICS				
Family	Rep. Rate	Pulse Width	t_{TLH}	t_{THL}
54F	1MHz	500ns	$\leq 2.5ns$	$\leq 2.5ns$