

## DYNAMIC CHARACTERISTICS

Parameters / Test Conditions	Symbol	Min.	Max.	Unit
Gate Charge: On-State Gate Charge Gate to Source Charge Gate to Drain Charge	$Q_{g(on)}$ $Q_{gs}$ $Q_{gd}$		8.6 1.5 5.5	nC
		$V_{GS} = 10V, I_D = 2.25A$ $V_{DS} = 100V$		

## SWITCHING CHARACTERISTICS

Parameters / Test Conditions	Symbol	Min.	Max.	Unit
Switching time tests: Turn-on delay time Rinse time Turn-off delay time Fall time	$t_{d(on)}$ $t_r$ $t_{d(off)}$ $t_f$		15 20 30 20	ns
		$I_D = 2.25A, V_{GS} = 10Vdc,$ Gate drive impedance = $7.5\Omega,$ $V_{DD} = 100Vdc$		
Diode Reverse Recovery Time	$t_{rr}$		350	ns
		$di/dt \leq 100A/\mu s, V_{DD} \leq 50V,$ $I_F = 2.25A$		

## PACKAGE DIMENSIONS

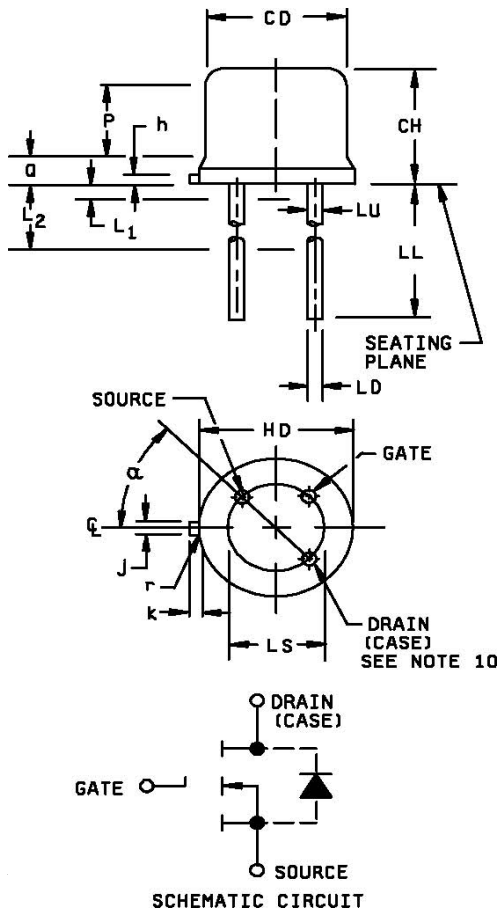

Ltr	Dimensions				Notes
	Inches		Millimeters		
	Min	Max	Min	Max	
CD	.305	.355	7.75	9.02	
CH	.160	.180	4.07	4.57	
HD	.335	.370	8.51	9.39	
h	.009	.041	0.23	1.04	
J	.028	.034	0.72	0.86	2
k	.029	.045	0.74	1.14	3
LD	.016	.021	0.41	0.53	7, 8
LL	.500	.750	12.7	19.05	7, 8
LS	.200 TP		5.08 TP		6
LU	.016	.019	0.41	0.48	7, 8
L <sub>1</sub>		.050		1.27	7, 8
L <sub>2</sub>	.250		6.35		7, 8
P	.070		1.78		5
Q		.050		1.27	4
r		.010		0.25	9
α	45° TP		45° TP		6

- 1 Dimensions are in inches. Millimeters are given for general information only.
- 2 Beyond radius (r) maximum, j shall be held for a minimum length of .011 (0.028 mm).
- 3 Dimension k measured from maximum HD.
- 4 Outline in this zone is not controlled.
- 5 Dimension CD shall not vary more than .010 (0.25 mm) in zone P. This zone is controlled for automatic handling.
- 6 Leads at gauge plane .054 +.001, -.000 (1.37 +0.03, -0.00 mm) below seating plane shall be within .007 (0.18 mm) radius of true position (TP) at maximum material condition (MMC) relative to tab at MMC.
- 7 LU applies between L<sub>1</sub> and L<sub>2</sub>. LD applies between L<sub>2</sub> and L minimum. Diameter is uncontrolled in L<sub>1</sub> and beyond LL minimum.
- 8 All three leads.
- 9 Radius (r) applies to both inside corners of tab.
- 10 Drain is electrically connected to the case.
- 11 In accordance with ASME Y14.5M, diameters are equivalent to φx symbology.

**FIGURE 1. Physical dimensions for TO-205AF.**

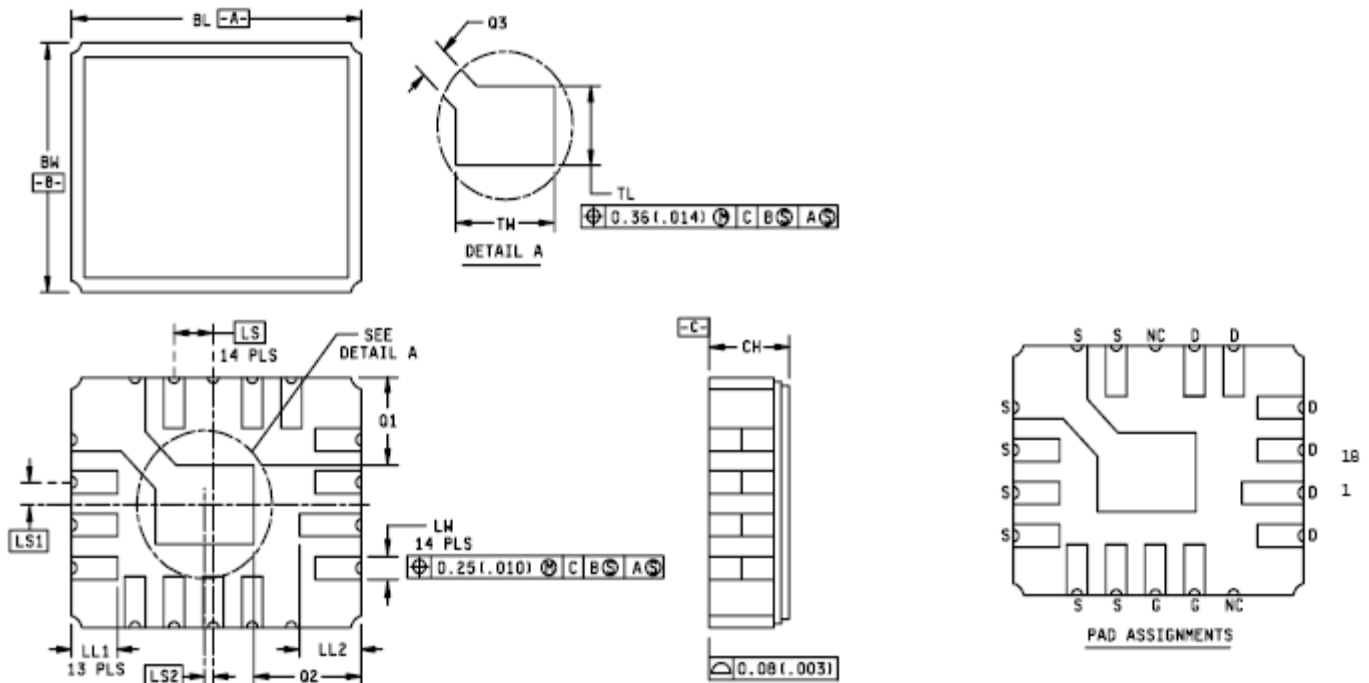

## NOTES:

- 1 Dimensions are in inches.
- 2 Millimeters are given for general information only.
- 3 In accordance with ASME Y14.5M, diameters are equivalent to  $\phi x$  symbology.
- 4 Ceramic package only.

Ltr	Dimensions			
	Inches		Millimeters	
	Min	Max	Min	Max
BL	.345	.360	8.77	
BW	.280	.295	7.11	
CH	.095	.115	2.41	
LL <sub>1</sub>	.040	.055	1.02	
LL <sub>2</sub>	.055	.065	1.40	
LS	.050 BSC		1.27 BSC	
LS <sub>1</sub>	.025 BSC		0.635 BSC	
LS <sub>2</sub>	.008 BSC		0.203 BSC	
LW	.020	.030	0.51	0.76
Q <sub>1</sub>	.105 REF		2.67 REF	
Q <sub>2</sub>	.120 REF		3.05 REF	
Q <sub>3</sub>	.045	.055	1.14	1.40
TL	.070	.080	1.78	2.03
TW	.120	.130	3.05	3.30

**FIGURE 2. Physical dimensions for LCC.**