

# Improved, Quad, SPST Analog Switches

## ABSOLUTE MAXIMUM RATINGS

(All Voltages Referenced to V-.)

V+	.....44V
GND	.....25V
V <sub>L</sub>	.....(GND -0.3V) to (V+ +0.3V)
Digital Inputs, V <sub>S</sub> , V <sub>D</sub> (Note 1)	.....(V- -2V) to (V+ +2V) or 30mA (whichever occurs first)
Continuous Current (any terminal)	.....30mA
Peak Current (pulsed at 1ms, 10% duty cycle max)	.....100mA

Continuous Power Dissipation (T<sub>A</sub> = +70°C)

16-Pin Plastic DIP (derate 10.53mW/°C above +70°C)	.842mW
16-Pin Narrow SO (derate 8.70mW/°C above +70°C)	...696mW
16-Pin CERDIP (derate 10.00mW/°C above +70°C)	.....800mW
16-Pin TSSOP (derate 6.7mW/°C above +70°C)	.....457mW
16-Pin QFN (derate 19.2mW/°C above +70°C)	.....1538mW

Operating Temperature Ranges

DG41_C	.....0°C to +70°C
DG41_D	.....-40°C to +85°C
DG41_AK	.....-55°C to +125°C
Storage Temperature Range	.....-65°C to +150°C
Lead Temperature (soldering, 10s)	.....+300°C

**Note 1:** Signals on S, D, or IN exceeding V+ or V- are clamped by internal diodes. Limit forward current to maximum current rating.

Stresses beyond those listed under "Absolute Maximum Ratings" may cause permanent damage to the device. These are stress ratings only, and functional operation of the device at these or any other conditions beyond those indicated in the operational sections of the specifications is not implied. Exposure to absolute maximum rating conditions for extended periods may affect device reliability.

## ELECTRICAL CHARACTERISTICS—Dual Supplies

(V+ = 15V, V- = -15V, V<sub>L</sub> = 5V, V<sub>GND</sub> = 0V, V<sub>INH</sub> = 2.4V, V<sub>INL</sub> = 0.8V, T<sub>A</sub> = T<sub>MIN</sub> to T<sub>MAX</sub>, unless otherwise noted.)

PARAMETER	SYMBOL	CONDITIONS		MIN	TYP (Note 2)	MAX	UNITS	
<b>SWITCH</b>								
Analog Signal Range	V <sub>ANALOG</sub>	(Note 3)		-15		15	V	
Drain-Source On-Resistance	R <sub>DS(ON)</sub>	V+ = 13.5V, V- = -13.5V, V <sub>D</sub> = ±8.5V, I <sub>S</sub> = -10mA	T <sub>A</sub> = +25°C	C, D	17	45	Ω	
				A	17	30		
			T <sub>A</sub> = T <sub>MIN</sub> to T <sub>MAX</sub>			45		
On-Resistance Match Between Channels (Note 4)	ΔR <sub>DS(ON)</sub>	V+ = 15V, V- = -15V, V <sub>D</sub> = ±10V, I <sub>S</sub> = -10mA	T <sub>A</sub> = +25°C			3	Ω	
				T <sub>A</sub> = T <sub>MIN</sub> to T <sub>MAX</sub>		5		
On-Resistance Flatness (Note 4)	R <sub>FLAT(ON)</sub>	V+ = 15V, V- = -15V, V <sub>D</sub> = ±5V, 0V, I <sub>S</sub> = -10mA	T <sub>A</sub> = +25°C			4	Ω	
				T <sub>A</sub> = T <sub>MIN</sub> to T <sub>MAX</sub>		6		
Source Off-Leakage Current (Note 7)	I <sub>S(OFF)</sub>	V+ = 16.5V, V- = -16.5V, V <sub>D</sub> = ±15.5V, V <sub>S</sub> = ±15.5V	T <sub>A</sub> = +25°C	C, D, A	-0.25	-0.10	0.25	nA
				C, D	-5		5	
				A	-10		10	
Drain Off-Leakage Current (Note 7)	I <sub>D(OFF)</sub>	V+ = 16.5V, V- = -16.5V, V <sub>D</sub> = ±15.5V, V <sub>S</sub> = ±15.5V	T <sub>A</sub> = +25°C	C, D, A	-0.25	-0.10	0.25	nA
				C, D	-5		5	
				A	-10		10	
Drain On-Leakage Current (Note 7)	I <sub>D(ON)</sub> + I <sub>S(ON)</sub>	V+ = 16.5V, V- = -16.5V, V <sub>D</sub> = ±15.5V, V <sub>S</sub> = ±15.5V	T <sub>A</sub> = +25°C	C, D, A	-0.4	-0.1	0.4	nA
				C, D	-20		20	
				A	-40		40	

# Improved, Quad, SPST Analog Switches

DG411/DG412/DG413

## ELECTRICAL CHARACTERISTICS—Dual Supplies (continued)

(V+ = 15V, V- = -15V, VL = 5V, V<sub>GND</sub> = 0V, V<sub>INH</sub> = 2.4V, V<sub>INL</sub> = 0.8V, T<sub>A</sub> = T<sub>MIN</sub> to T<sub>MAX</sub>, unless otherwise noted.)

PARAMETER	SYMBOL	CONDITIONS	MIN	TYP (Note 2)	MAX	UNITS	
<b>INPUT</b>							
Input Current with Input Voltage High	I <sub>INH</sub>	I <sub>N</sub> = 2.4V, all others = 0.8V	-0.500	0.005	0.500	μA	
Input Current with Input Voltage Low	I <sub>INL</sub>	I <sub>N</sub> = 0.8V, all others = 2.4V	-0.500	0.005	0.500	μA	
<b>SUPPLY</b>							
Power-Supply Range			±4.5		±20.0	V	
Positive Supply Current	I <sub>+</sub>	All channels on or off, V <sub>+</sub> = 16.5V, V <sub>-</sub> = -16.5V, V <sub>IN</sub> = 0V or 5V	T <sub>A</sub> = +25°C	-1	0.0001	1	μA
			T <sub>A</sub> = T <sub>MIN</sub> to T <sub>MAX</sub>	-5		5	
Negative Supply Current	I <sub>-</sub>	All channels on or off, V <sub>+</sub> = 16.5V, V <sub>-</sub> = -16.5V, V <sub>IN</sub> = 0V or 5V	T <sub>A</sub> = +25°C	-1	-0.0001	1	μA
			T <sub>A</sub> = T <sub>MIN</sub> to T <sub>MAX</sub>	-5		5	
Logic Supply Current	I <sub>L</sub>	All channels on or off, V <sub>+</sub> = 16.5V, V <sub>-</sub> = -16.5V, V <sub>IN</sub> = 0V or 5V	T <sub>A</sub> = +25°C	-1	0.0001	1	μA
			T <sub>A</sub> = T <sub>MIN</sub> to T <sub>MAX</sub>	-5		5	
Ground Current	I <sub>GND</sub>	All channels on or off, V <sub>+</sub> = 16.5V, V <sub>-</sub> = -16.5V, V <sub>IN</sub> = 0V or 5V	T <sub>A</sub> = +25°C	-1	-0.0001	1	μA
			T <sub>A</sub> = T <sub>MIN</sub> to T <sub>MAX</sub>	-5		5	
<b>DYNAMIC</b>							
Turn-On Time	t <sub>ON</sub>	V <sub>D</sub> = ±10V, Figure 2	T <sub>A</sub> = +25°C	110	175	ns	
			T <sub>A</sub> = T <sub>MIN</sub> to T <sub>MAX</sub>				220
Turn-Off Time	t <sub>OFF</sub>	V <sub>D</sub> = ±10V, Figure 2	T <sub>A</sub> = +25°C	100	145	ns	
			T <sub>A</sub> = T <sub>MIN</sub> to T <sub>MAX</sub>				160
Break-Before-Make Time Delay	t <sub>D</sub>	DG413 only, R <sub>L</sub> = 300Ω, C <sub>L</sub> = 35pF, Figure 3	T <sub>A</sub> = +25°C	25		ns	
Charge Injection (Note 3)	Q	C <sub>L</sub> = 1.0nF, V <sub>GEN</sub> = 0V, R <sub>GEN</sub> = 0Ω, Figure 4	T <sub>A</sub> = +25°C	5	10	pC	
Off-Isolation (Note 5)	OIRR	R <sub>L</sub> = 50Ω, C <sub>L</sub> = 5pF, f = 1MHz, Figure 5	T <sub>A</sub> = +25°C	68		dB	
Crosstalk (Note 6)		R <sub>L</sub> = 50Ω, C <sub>L</sub> = 5pF, f = 1MHz, Figure 6	T <sub>A</sub> = +25°C	85		dB	
Source Off-Capacitance	C <sub>S(OFF)</sub>	f = 1MHz, Figure 7	T <sub>A</sub> = +25°C	9		pF	
Drain Off-Capacitance	C <sub>D(OFF)</sub>	f = 1MHz, Figure 7	T <sub>A</sub> = +25°C	9		pF	
Drain On-Capacitance	C <sub>D(ON)</sub> + C <sub>S(ON)</sub>	f = 1MHz, Figure 8	T <sub>A</sub> = +25°C	35		pF	

# Improved, Quad, SPST Analog Switches

## ELECTRICAL CHARACTERISTICS—Single Supply

(V+ = 12V, V- = 0V, VL = 5V, VGND = 0V, VINH = 2.4V, VINL = 0.8V, TA = TMIN to TMAX, unless otherwise noted.)

PARAMETER	SYMBOL	CONDITIONS		MIN	TYP (Note 2)	MAX	UNITS
<b>SWITCH</b>							
Analog Signal Range	VANALOG	(Note 3)		0		12	V
Drain-Source On-Resistance	RDS(ON)	V+ = 10.8V, VD = 3.8V, IS = -10mA	TA = +25°C		40	80	Ω
			TA = TMIN to TMAX			100	
<b>SUPPLY</b>							
Positive Supply Current	I+	All channels on or off, V+ = 13.2V, VIN = 0V or 5V	TA = +25°C	-1	0.0001	1	μA
			TA = TMAX	-5		5	
Negative Supply Current	I-	All channels on or off, V+ = 13.2V, VIN = 0V or 5V	TA = +25°C	-1	0.0001	1	μA
			TA = TMAX	-5		5	
Logic Supply Current	IL	All channels on or off, VL = 5.25V, VIN = 0V or 5V	TA = +25°C	-1	0.0001	1	μA
			TA = TMAX	-5		5	
Ground Current	IGND	All channels on or off, VL = 5.25V, VIN = 0V or 5V	TA = +25°C	-1	-0.0001	1	μA
			TA = TMAX	-5		5	
<b>DYNAMIC</b>							
Turn-On Time	tON	VS = 8V, Figure 2	TA = +25°C		175	250	ns
			TA = TMIN to TMAX			315	
Turn-Off Time	tOFF	VS = 8V, Figure 2	TA = +25°C		95	125	ns
			TA = TMIN to TMAX			140	
Break-Before-Make Time Delay	tD	DG413 only, RL = 300Ω, CL = 35pF, Figure 3	TA = +25°C		25		ns
Charge Injection (Note 3)	Q	CL = 1.0nF, VGEN = 0V, RGEN = 0V, Figure 4	TA = +25°C		5	10	pC

**Note 2:** The algebraic convention, where the most negative value is a minimum and the most positive value a maximum, is used in this data sheet.

**Note 3:** Guaranteed by design.

**Note 4:** ΔRON = ΔRON max - ΔRON min. On-resistance match between channels and flatness are guaranteed only with bipolar-supply operation. Flatness is defined as the difference between the maximum and minimum value of on-resistance as measured at the extremes of the specified analog signal range.

**Note 5:** Off-Isolation = 20log(VD/VS), VD = output, VS = input to off switch. See Figure 5.

**Note 6:** Between any two switches. See Figure 6.

**Note 7:** Leakage parameters IS(OFF), ID(OFF), and ID(ON) are 100% tested at the maximum-rated hot temperature and guaranteed by correlation at +25°C.

# Improved, Quad, SPST Analog Switches

## Typical Operating Characteristics

( $T_A = +25^\circ\text{C}$ , unless otherwise noted.)

DG411/DG412/DG413

**ON-RESISTANCE vs.  $V_D$  AND POWER-SUPPLY VOLTAGE**

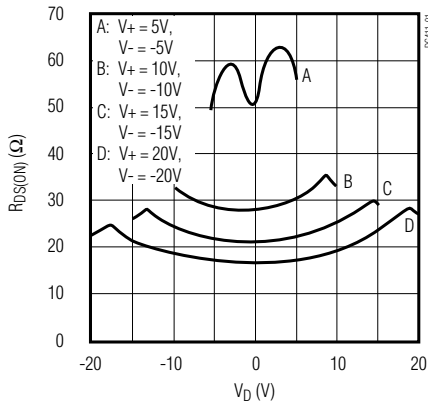

**ON-RESISTANCE vs.  $V_D$  AND TEMPERATURE**

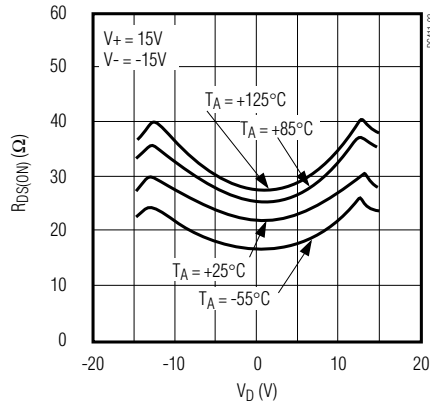

**ON-RESISTANCE vs.  $V_D$  AND TEMPERATURE (SINGLE SUPPLY)**

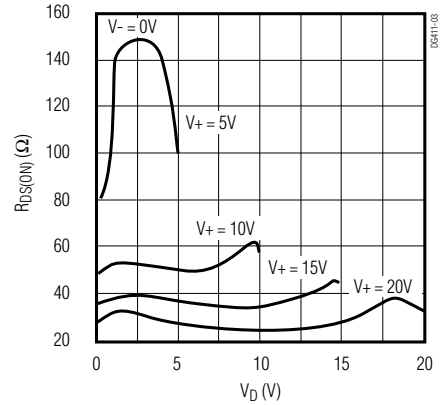

**ON-RESISTANCE vs.  $V_D$  (SINGLE SUPPLY)**

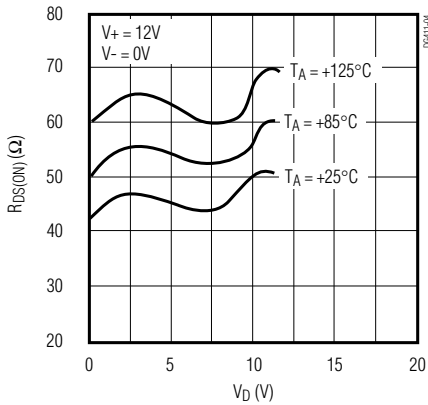

**OFF-LEAKAGE CURRENTS vs. TEMPERATURE**

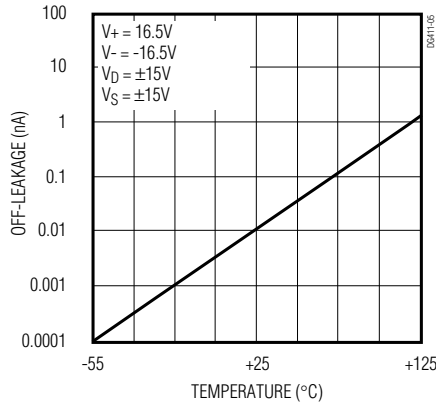

**ON-LEAKAGE CURRENTS vs. TEMPERATURE**

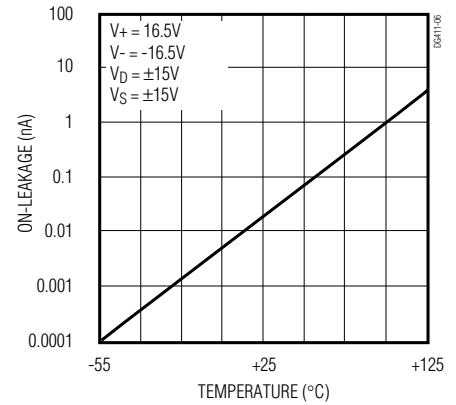

**CHARGE INJECTION vs. ANALOG VOLTAGE**

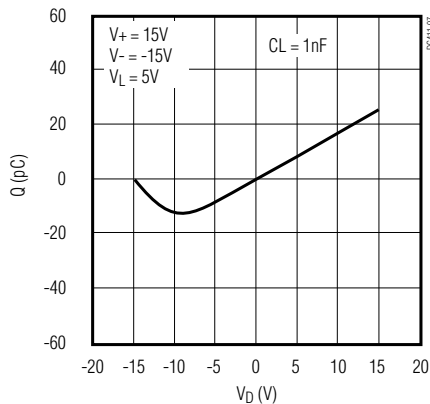

**SUPPLY CURRENT vs. TEMPERATURE**

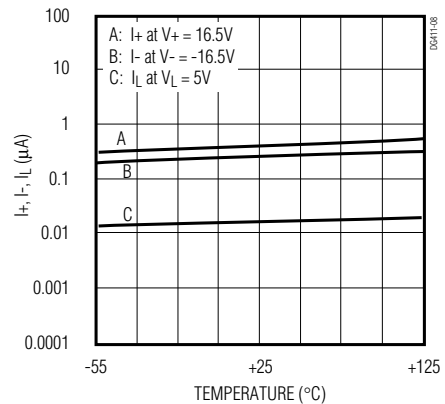

# Improved, Quad, SPST Analog Switches

## Pin Description

PIN		NAME	FUNCTION
DIP/SO/TSSOP	QFN		
1, 16, 9, 8	15, 14, 7, 6	IN1–IN4	Input
2, 15, 10, 7	16, 13, 8, 5	D1–D4	Analog Switch Drain Terminal
3, 14, 11, 6	1, 12, 9, 4	S1–S4	Analog Switch Source Terminal
4	2	V-	Negative-Supply Voltage Input
5	3	GND	Ground
12	10	V <sub>L</sub>	Logic Supply Voltage
13	11	V+	Positive-Supply Voltage Input—Connected to Substrate
—	—	EP	Exposed Paddle (QFN Only). Connect EP to V+.

## Applications Information

### Operation with Supply Voltages Other Than 15V

Using supply voltages other than 15V will reduce the analog signal range. The DG411/DG412/DG413 switches operate with  $\pm 4.5\text{V}$  to  $\pm 20\text{V}$  bipolar supplies or with a +10V to +30V single supply; connect V- to 0V when operating with a single supply. Also, all device types can operate with unbalanced supplies such as +24V and -5V. V<sub>L</sub> must be connected to +5V to be TTL compatible, or to V+ for CMOS-logic level inputs. The *Typical Operating Characteristics* graphs show typical on-resistance with  $\pm 15\text{V}$ ,  $\pm 10\text{V}$ , and  $\pm 5\text{V}$  supplies. (Switching times increase by a factor of two or more for operation at  $\pm 5\text{V}$ .)

### Overvoltage Protection

Proper power-supply sequencing is recommended for all CMOS devices. Do not exceed the absolute maximum ratings because stresses beyond the listed ratings may cause permanent damage to the devices. Always sequence V+ on first, followed by V<sub>L</sub>, V-, and logic inputs. If power-supply sequencing is not possible, add two small, external signal diodes in series with supply pins for overvoltage protection (Figure 1).

Adding diodes reduces the analog signal range to 1V below V+ and 1V below V-, without affecting low switch resistance and low leakage characteristics. Device operation is unchanged, and the difference between V+ and V- should not exceed +44V.

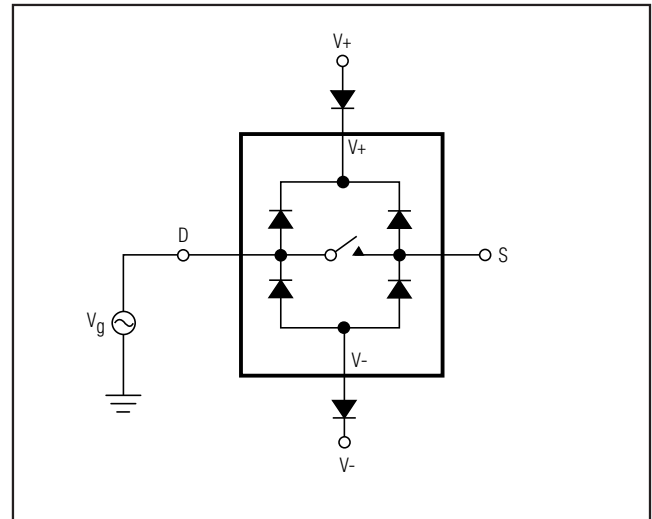

Figure 1. Overvoltage Protection Using External Blocking Diodes

# Improved, Quad, SPST Analog Switches

## Timing Diagrams/Test Circuits

DG411/DG412/DG413

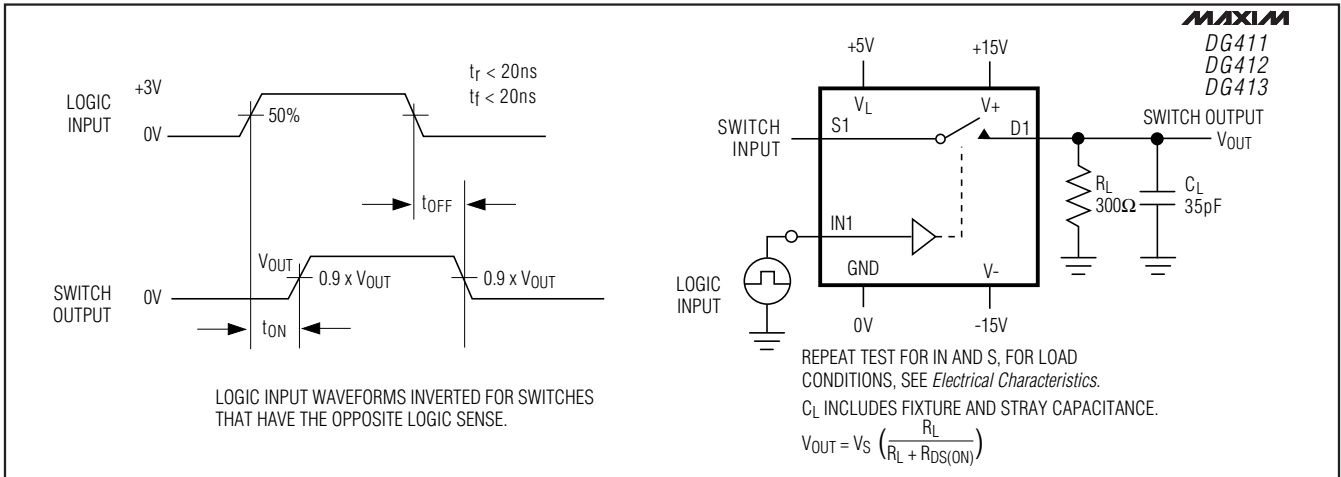

Figure 2. Switching-Time

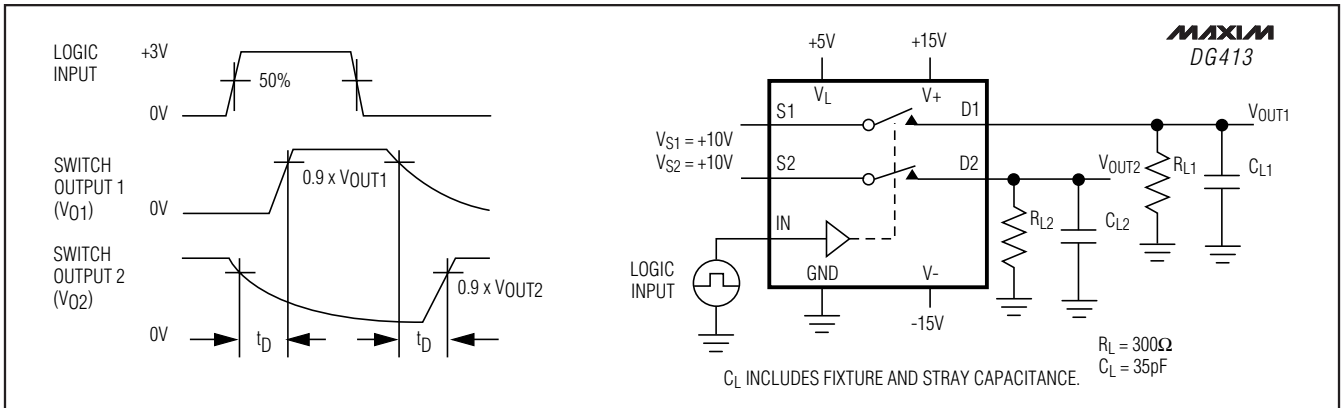

Figure 3. DG413 Break-Before-Make

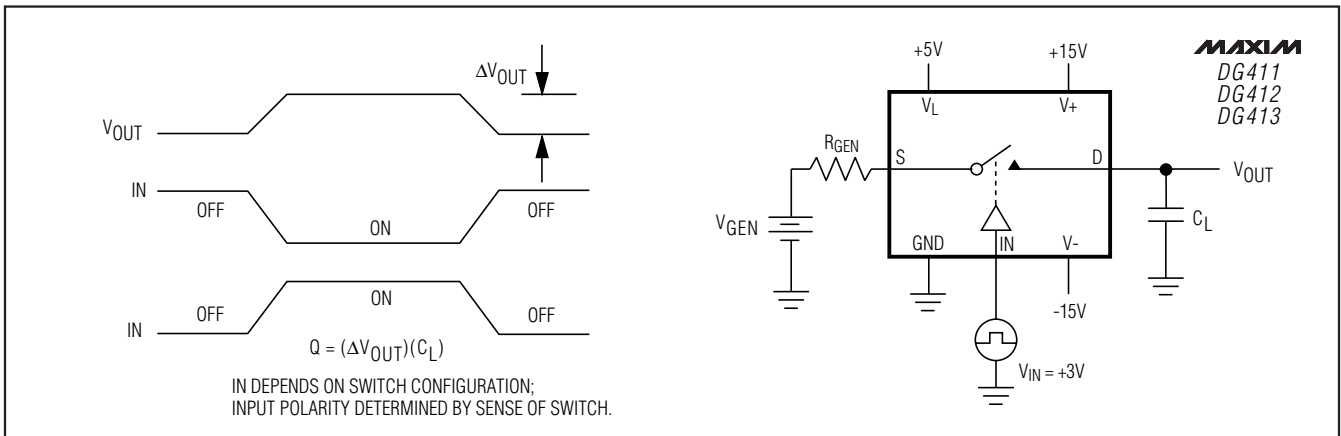

Figure 4. Charge-Injection

# Improved, Quad, SPST Analog Switches

## Timing Diagrams/Test Circuits (continued)

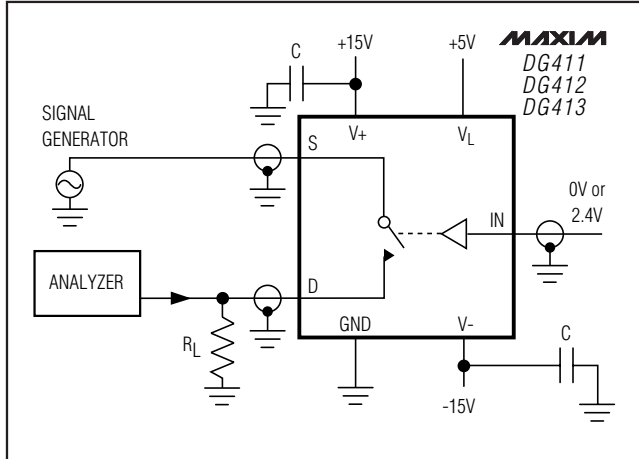

Figure 5. Off-Isolation

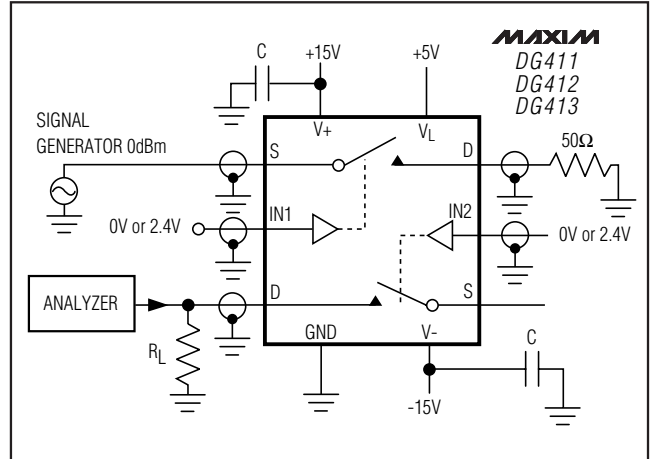

Figure 6. Crosstalk

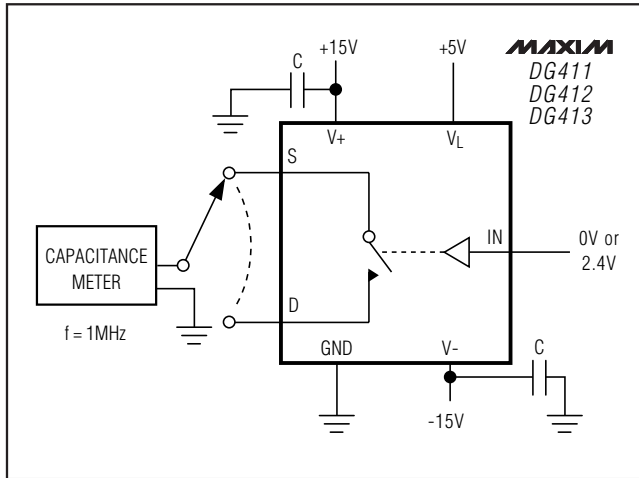

Figure 7. Channel Off-Capacitance

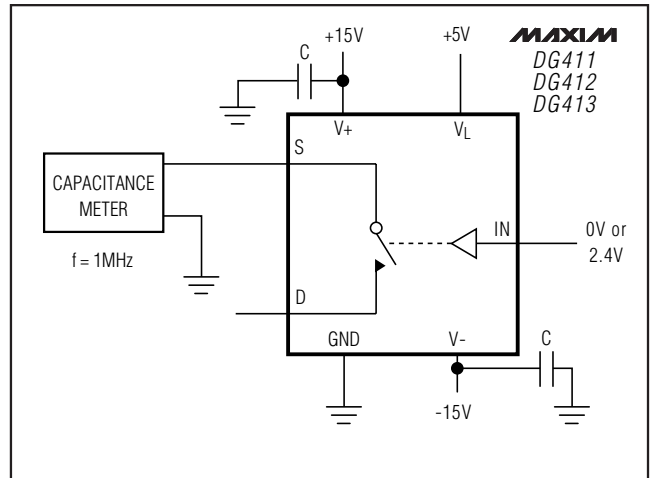

Figure 8. Channel On-Capacitance

# Improved, Quad, SPST Analog Switches

DG411/DG412/DG413

## Ordering Information (continued)

PART	TEMP RANGE	PIN-PACKAGE
DG411EGE	-40°C to +85°C	16 QFN-EP*
DG411DJ	-40°C to +85°C	16 Plastic DIP
DG411DY	-40°C to +85°C	16 Narrow SO
DG411DK	-40°C to +85°C	16 CERDIP
DG411AK	-55°C to +125°C	16 CERDIP**
DG411MY/PR	-55°C to +125°C	16 SO***
DG411MY/PR-T	-55°C to +125°C	16 SO***
<b>DG412CJ</b>	0°C to +70°C	16 Plastic DIP
DG412CUE	0°C to +70°C	16 TSSOP
DG412EUE	-40°C to +85°C	16 TSSOP
DG412CY	0°C to +70°C	16 Narrow SO
DG412C/D	0°C to +70°C	Dice†
DG412DJ	-40°C to +85°C	16 Plastic DIP
DG412EGE	-40°C to +85°C	16 QFN-EP*
DG412DY	-40°C to +85°C	16 Narrow SO
DG412DK	-40°C to +85°C	16 CERDIP
DG412AK	-55°C to +125°C	16 CERDIP**
DG412MY/PR	-55°C to +125°C	16 SO***
DG412MY/PR-T	-55°C to +125°C	16 SO***
<b>DG413CJ</b>	0°C to +70°C	16 Plastic DIP
DG413CUE	0°C to +70°C	16 TSSOP
DG413EUE	-40°C to +85°C	16 TSSOP
DG413CY	0°C to +70°C	16 Narrow SO
DG413C/D	0°C to +70°C	Dice†
DG413EGE	-40°C to +85°C	16 QFN-EP*
DG413DJ	-40°C to +85°C	16 Plastic DIP
DG413DY	-40°C to +85°C	16 Narrow SO
DG413DK	-40°C to +85°C	16 CERDIP
DG413AK	-55°C to +125°C	16 CERDIP**

†Contact factory for dice specifications.

\*EP = Exposed pad.

\*\*Contact factory for availability and processing to MIL-STD-883B.

\*\*\*Contact factory for availability.

## Chip Topography

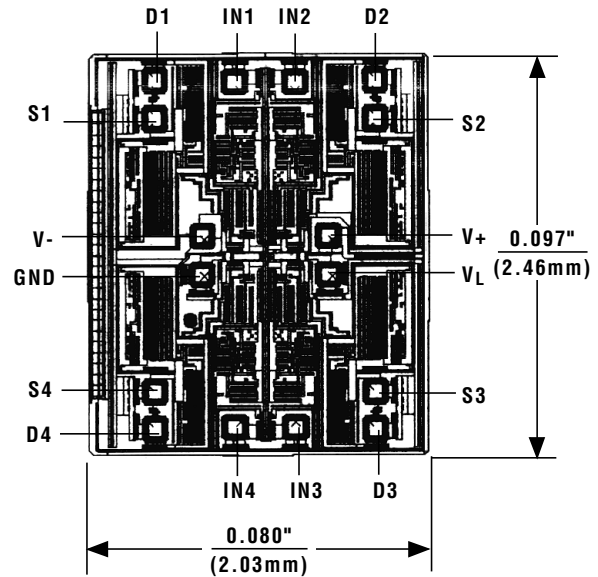



# Improved, Quad, SPST Analog Switches

## Pin Configurations/Functional Diagrams (continued)

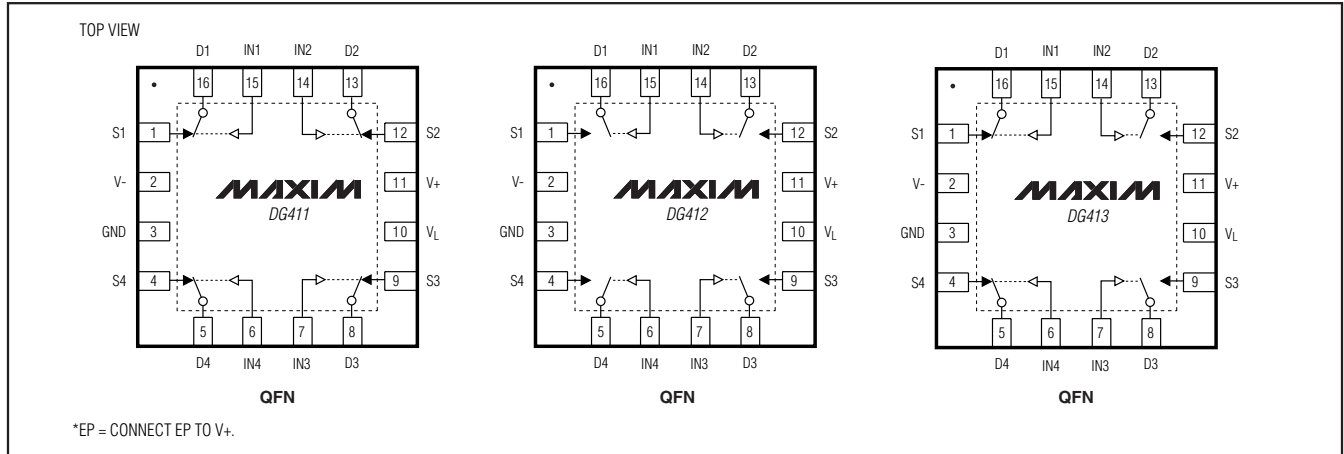

# Improved, Quad, SPST Analog Switches

## Package Information

For the latest package outline information and land patterns, go to [www.maxim-ic.com/packages](http://www.maxim-ic.com/packages).

PACKAGE TYPE	PACKAGE CODE	DOCUMENT NO.
16 QFN-EP	G1655-3	<a href="#">21-0091</a>
16 Plastic DIP	P16-1	<a href="#">21-0043</a>
16 TSSOP	U16-2	<a href="#">21-0066</a>
16 CERDIP	J16-3	<a href="#">21-0045</a>
16 Narrow SO	S16-1	<a href="#">21-0041</a>
16 SO	S16-1	<a href="#">21-0041</a>

DG411/DG412/DG413

# Improved, Quad, SPST Analog Switches

## Revision History

REVISION NUMBER	REVISION DATE	DESCRIPTION	PAGES CHANGED
6	9/07	Addition of exposed pad information	1, 6, 9, 14, 15
7	9/08	Addition of rugged plastic information	1, 9

Maxim cannot assume responsibility for use of any circuitry other than circuitry entirely embodied in a Maxim product. No circuit patent licenses are implied. Maxim reserves the right to change the circuitry and specifications without notice at any time.

12 **Maxim Integrated Products, 120 San Gabriel Drive, Sunnyvale, CA 94086 408-737-7600**

© 2008 Maxim Integrated Products

**MAXIM** is a registered trademark of Maxim Integrated Products, Inc.