

AD7228A—SPECIFICATIONS

DUAL SUPPLY ($V_{DD} = 10.8\text{ V to }16.5\text{ V}$; $V_{SS} = -5\text{ V} \pm 10\%$; $GND = 0\text{ V}$; $V_{REF} = +2\text{ V to }+10\text{ V}^1$; $R_L = 2\text{ k}\Omega$, $C_L = 100\text{ pF}$ unless otherwise noted.) All specifications T_{MIN} to T_{MAX} unless otherwise noted.

Parameter	B Version ²	C Version	T Version	U Version	Units	Conditions/Comments
STATIC PERFORMANCE						
Resolution	8	8	8	8	Bits	$V_{DD} = +15\text{ V} \pm 10\%$, $V_{REF} = +10\text{ V}$
Total Unadjusted Error ³	± 2	± 1	± 2	± 1	LSB max	
Relative Accuracy	± 1	$\pm 1/2$	± 1	$\pm 1/2$	LSB max	
Differential Nonlinearity	± 1	± 1	± 1	± 1	LSB max	
Full-Scale Error ⁴	± 1	$\pm 1/2$	± 1	$\pm 1/2$	LSB max	
Zero Code Error						Guaranteed Monotonic
@ 25°C	± 25	± 15	± 25	± 15	mV max	Typical tempco is 5 ppm/°C with $V_{REF} = +10\text{ V}$
T_{MIN} to T_{MAX}	± 30	± 20	± 30	± 20	mV max	Typical tempco is 30 $\mu\text{V}/^\circ\text{C}$
Minimum Load Resistance	2	2	2	2	k Ω min	$V_{OUT} = +10\text{ V}$
REFERENCE INPUT						
Voltage Range ¹	2 to 10	2 to 10	2 to 10	2 to 10	V min/V max	Occurs when each DAC is loaded with all 1s. $V_{REF} = 8\text{ V p-p Sine Wave @ }10\text{ kHz}$
Input Resistance	2	2	2	2	k Ω min	
Input Capacitance ⁵	500	500	500	500	pF max	
AC Feedthrough	-70	-70	-70	-70	dB typ	
DIGITAL INPUTS						
Input High Voltage, V_{INH}	2.4	2.4	2.4	2.4	V min	$V_{IN} = 0\text{ V or }V_{DD}$
Input Low Voltage, V_{INL}	0.8	0.8	0.8	0.8	V max	
Input Leakage Current	± 1	± 1	± 1	± 1	$\mu\text{A max}$	
Input Capacitance ⁵	8	8	8	8	pF max	
Input Coding	Binary	Binary	Binary	Binary		
DYNAMIC PERFORMANCE⁵						
Voltage Output Slew Rate	2	2	2	2	V/ $\mu\text{s min}$	$V_{REF} = +10\text{ V}$; Settling Time to $\pm 1/2\text{ LSB}$ $V_{REF} = +10\text{ V}$; Settling Time to $\pm 1/2\text{ LSB}$ Code transition all 0s to all 1s. $V_{REF} = 0\text{ V}$; $\overline{WR} = V_{DD}$ Code transition all 0s to all 1s. $V_{REF} = +10\text{ V}$; $\overline{WR} = 0\text{ V}$
Voltage Output Settling Time						
Positive Full-Scale Change	5	5	5	5	$\mu\text{s max}$	
Negative Full-Scale Change	5	5	5	5	$\mu\text{s max}$	
Digital Feedthrough	50	50	50	50	nV secs typ	
Digital Crosstalk ⁶	50	50	50	50	nV secs typ	
POWER SUPPLIES						
V_{DD} Range	10.8/16.5	10.8/16.5	10.8/16.5	10.8/16.5	V min/V max	For Specified Performance
V_{SS} Range	-4.5/-5.5	-4.5/-5.5	-4.5/-5.5	-4.5/-5.5	V min/V max	
I_{DD}						Outputs Unloaded; $V_{IN} = V_{INL}$ or V_{INH}
@ 25°C	16	16	16	16	mA max	
T_{MIN} to T_{MAX}	20	20	22	22	mA max	
I_{SS}						Outputs Unloaded; $V_{IN} = V_{INL}$ or V_{INH}
@ 25°C	14	14	14	14	mA max	
T_{MIN} to T_{MAX}	18	18	20	20	mA max	

SINGLE SUPPLY ($V_{DD} = +15\text{ V} \pm 10\%$, $V_{SS} = GND = 0\text{ V}$; $V_{REF} = +10\text{ V}$, $R_L = 2\text{ k}\Omega$, $C_L = 100\text{ pF}$ unless otherwise noted.) All specifications T_{MIN} to T_{MAX} unless otherwise noted.

Parameter	B Version ²	C Version	T Version	U Version	Units	Conditions/Comments
STATIC PERFORMANCE						
Resolution	8	8	8	8	Bits	Guaranteed Monotonic $V_{OUT} = +10\text{ V}$
Total Unadjusted Error ³	± 2	± 1	± 2	± 1	LSB max	
Differential Nonlinearity	± 1	± 1	± 1	± 1	LSB max	
Minimum Load Resistance	2	2	2	2	k Ω min	
REFERENCE INPUT						
Input Resistance	2	2	2	2	k Ω min	Occurs when each DAC is loaded with all 1s.
Input Capacitance ⁵	500	500	500	500	pF max	
DIGITAL INPUTS						
	As per Dual Supply Specifications					
DYNAMIC PERFORMANCE⁵						
Voltage Output Slew Rate	2	2	2	2	V/ $\mu\text{s min}$	Settling Time to $\pm 1/2\text{ LSB}$ Settling Time to $\pm 1/2\text{ LSB}$ Code transition all 0s to all 1s. $V_{REF} = 0\text{ V}$; $\overline{WR} = V_{DD}$ Code transition all 0s to all 1s. $V_{REF} = +10\text{ V}$; $\overline{WR} = 0\text{ V}$
Voltage Output Settling Time						
Positive Full-Scale Change	5	5	5	5	$\mu\text{s max}$	
Negative Full-Scale Change	7	7	7	7	$\mu\text{s max}$	
Digital Feedthrough	50	50	50	50	nV secs typ	
Digital Crosstalk ⁶	50	50	50	50	nV secs typ	
POWER SUPPLIES						
V_{DD} Range	13.5/16.5	13.5/16.5	13.5/16.5	13.5/16.5	V min/V max	For Specified Performance
I_{DD}						
@ 25°C	16	16	16	16	mA max	
T_{MIN} to T_{MAX}	20	20	22	22	mA max	

NOTES

¹ V_{OUT} must be less than V_{DD} by 3.5 V to ensure correct operation.

²Temperature ranges are as follows:

B, C Versions: -40°C to +85°C

T, U Versions: -55°C to +125°C

³Total Unadjusted Error includes zero code error, relative accuracy and full-scale error.

⁴Calculated after zero code error has been adjusted out.

⁵Sample tested at 25°C to ensure compliance.

⁶The glitch impulse transferred to the output of one converter (not addressed) due to a change in the digital input code to another addressed converter.

Specifications subject to change without notice.

+5 V SUPPLY OPERATION ($V_{DD} = +5 V \pm 5\%$, $V_{SS} = 0$ to $-5 V \pm 10\%$, $GND = 0 V$, $V_{REF} = +1.25 V$, $R_L = 2 k\Omega$, $C_L = 100 pF$ unless otherwise noted.) All specifications T_{MIN} to T_{MAX} unless otherwise noted.

Parameter	B Version	C Version	T Version	U Version	Units	Conditions/Comments
STATIC PERFORMANCE						
Resolution	8	8	8	8	Bits	Guaranteed Monotonic
Relative Accuracy	± 2	± 2	± 2	± 2	LSB max	
Differential Nonlinearity	± 1	± 1	± 1	± 1	LSB max	
Full-Scale Error	± 4	± 2	± 4	± 2	LSB max	
Zero Code Error						
@ 25°C	± 30	± 20	± 30	± 20	mV max	
T_{MIN} to T_{MAX}	± 40	± 30	± 40	± 30	mV max	
REFERENCE INPUT						
Reference Input Range	1.2 1.3	1.2 1.3	1.2 1.3	1.2 1.3	V min V max	
Reference Input Resistance	2	2	2	2	k Ω min	
Reference Input Capacitance	500	500	500	500	pF max	
POWER REQUIREMENTS						
Positive Supply Range	4.75/5.25	4.75/5.25	4.75/5.25	4.75/5.25	V min/V max	For Specified Performance
Positive Supply Current						
@ 25°C	16	16	16	16	μA max	
T_{MIN} to T_{MAX}	20	20	22	22	μA max	
Negative Supply Current						
@ 25°C	14	14	14	14	μA max	
T_{MIN} to T_{MAX}	18	18	20	20	μA max	

NOTES

All of the specifications as per Dual Supply Specifications except for negative full-scale settling-time when $V_{SS} = 0 V$. Specifications subject to change without notice.

SWITCHING CHARACTERISTICS^{1, 2} (See Figures 1, 2; $V_{DD} = +5 V \pm 5\%$ or $+10.8 V$ to $+16.5 V$; $V_{SS} = 0 V$ or $-5 V \pm 10\%$)

Parameters	Limit at 25°C All Grades	Limit at T_{MIN} , T_{MAX} (B, C Versions)	Limit at T_{MIN} , T_{MAX} (T, U Versions)	Units	Conditions/Comments
t_1	0	0	0	ns min	Address to \overline{WR} Setup Time Address to \overline{WR} Hold Time Data Valid to \overline{WR} Setup Time Data Valid to \overline{WR} Hold Time Write Pulse Width
t_2	0	0	0	ns min	
t_3	70	90	100	ns min	
t_4	10	10	10	ns min	
t_5	95	120	150	ns min	

NOTES

¹Sample tested at 25°C to ensure compliance. All input rise and fall times measured from 10% to 90% of +5 V, $t_r = t_f = 5 ns$.

²Timing measurement reference level is $\frac{V_{INH} + V_{INL}}{2}$.

INTERFACE LOGIC INFORMATION

Address lines A0, A1 and A2 select which DAC accepts data from the input port. Table I shows the selection table for the eight DACs with Figure 1 showing the input control logic. When the \overline{WR} signal is low, the input latch of the selected DAC is transparent, and its output responds to activity on the data bus. The data is latched into the addressed DAC latch on the rising edge of \overline{WR} . While \overline{WR} is high, the analog outputs remain at the value corresponding to the data held in their respective latches.

Table I. AD7228A Truth Table

AD7228A Control Inputs				AD7228A Operation
\overline{WR}	A2	A1	A0	
H	X	X	X	No Operation
L	L	L	L	Device Not Selected
L	L	L	H	DAC 1 Transparent
L	L	L	L	DAC 1 Latched
L	L	L	H	DAC 2 Transparent
L	L	H	L	DAC 3 Transparent
L	L	H	H	DAC 4 Transparent
L	H	L	L	DAC 5 Transparent
L	H	L	H	DAC 6 Transparent
L	H	H	L	DAC 7 Transparent
L	H	H	H	DAC 8 Transparent

H = High State L = Low State X = Don't Care

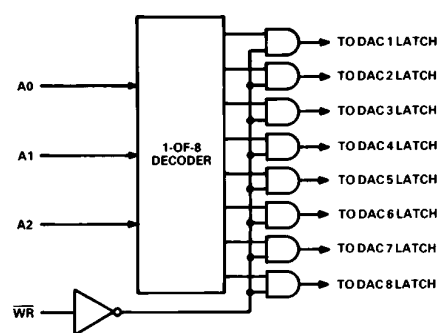
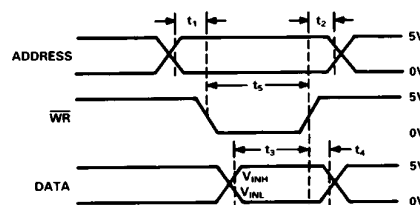

Figure 1. Input Control Logic



NOTE: THE SELECTED INPUT LATCH IS TRANSPARENT WHILE \overline{WR} IS LOW, THUS INVALID DATA DURING THIS TIME CAN CAUSE SPURIOUS OUTPUTS

Figure 2. Write Cycle Timing Diagram

AD7228A

ABSOLUTE MAXIMUM RATINGS¹

V_{DD} to GND	−0.3 V, +17 V
V_{DD} to V_{SS}	−0.3 V, +24 V
Digital Input Voltage to GND	−0.3 V, V_{DD}
V_{REF} to GND	−0.3V, V_{DD}
V_{OUT} to GND ²	V_{SS} , V_{DD}
Power Dissipation (Any Package) to +75°C	1000 mW
Derates above 75°C by	2.0 mW/°C
Operating Temperature	
Commercial	−40°C to +85°C
Industrial	−40°C to +85°C

Extended	−55°C to +125°C
Storage Temperature	−65°C to +150°C
Lead Temperature (Soldering, 10 secs)	+300°C

NOTES

¹Stresses above those listed under “Absolute Maximum Ratings” may cause permanent damage to the device. This is a stress rating only and functional operation of the device at these or any other conditions above those indicated in the operational sections of this specification is not implied. Exposure to absolute maximum rating conditions for extended periods may affect device reliability.

²Outputs may be shorted to any voltage in the range V_{SS} to V_{DD} provided that the power dissipation of the package is not exceeded. Typical short circuit current for a short to GND or V_{SS} is 50 mA.

CAUTION

ESD (electrostatic discharge) sensitive device. Electrostatic charges as high as 4000 V readily accumulate on the human body and test equipment and can discharge without detection. Although the AD7228A features proprietary ESD protection circuitry, permanent damage may occur on devices subjected to high energy electrostatic discharges. Therefore, proper ESD precautions are recommended to avoid performance degradation or loss of functionality.



PIN CONFIGURATIONS

DIP AND SOIC

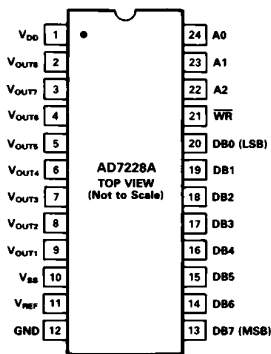

PLCC

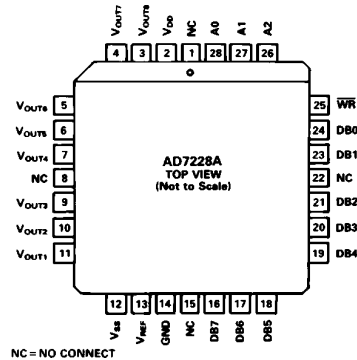

NC = NO CONNECT

CIRCUIT INFORMATION

D/A SECTION

The AD7228A contains eight identical, 8-bit, voltage-mode digital-to-analog converters. The output voltages from the converters have the same polarity as the reference voltage, allowing single supply operation. A novel DAC switch pair arrangement on the AD7228A allows a reference voltage range from +2 V to +10 V when operated from a V_{DD} of +15 V. Each DAC consists of a highly stable, thin-film, R-2R ladder and eight high-speed NMOS switches. The simplified circuit diagram for one channel is shown in Figure 3. Note that V_{REF} and GND are common to all eight DACs.

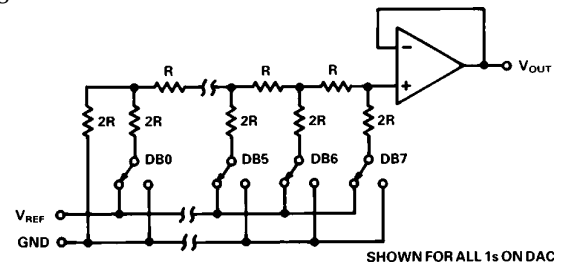

Figure 3. D/A Simplified Circuit Diagram

The input impedance at the V_{REF} pin of the AD7228A is the parallel combination of the eight individual DAC reference input impedances. It is code dependent and can vary from 2 k Ω to infinity. The lowest input impedance occurs when all eight DACs are loaded with digital code 01010101. Therefore, it is important that the external reference source presents a low output impedance to the V_{REF} terminal of the AD7228A under changing load conditions. Due to transient currents at the reference input during digital code changes a 0.1 μ F (or greater) decoupling capacitor is recommended on the V_{REF} input for dc applications. The nodal capacitance at the reference terminal is also code dependent and typically varies from 120 pF to 350 pF.

Each V_{OUT} pin can be considered as a digitally programmable voltage source with an output voltage:

$$V_{OUTN} = D_N \cdot V_{REF}$$

where D_N is a fractional representation of the digital input code and can vary from 0 to 255/256.

The output impedance is that of the output buffer amplifier as described in the following section.

OP AMP SECTION

Each voltage-mode D/A converter output is buffered by a unity gain noninverting CMOS amplifier. This buffer amplifier is tested with a 2 kΩ and 100 pF load but will typically drive a 2 kΩ and 500 pF load.

The AD7228A can be operated single or dual supply. Operating the part from single or dual supplies has no effect on the positive-going settling time. However, the negative-going settling time to voltages near 0 V in single supply will be slightly longer than the settling time for dual supply operation. Additionally, to ensure that the output voltage can go to 0 V in single supply, a transistor on the output acts as a passive pull-down as the output voltage nears 0 V. As a result, the sink capability of the amplifier is reduced as the output voltage nears 0 V in single supply. In dual supply operation, the full sink capability of 400 μA at 25°C is maintained over the entire output voltage range. The single supply output sink capability is shown in Figure 4. The negative V_{SS} also gives improved output amplifier performance allowing an extended input reference voltage range and giving improved slew rate at the output.

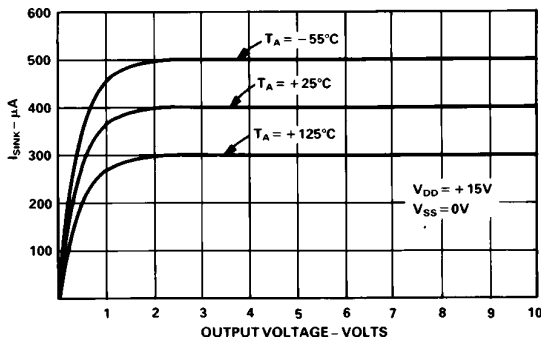

Figure 4. Single Supply Sink Current

The output broadband noise from the amplifier is 300 μV peak-to-peak. Figure 5 shows a plot of noise spectral density versus frequency.

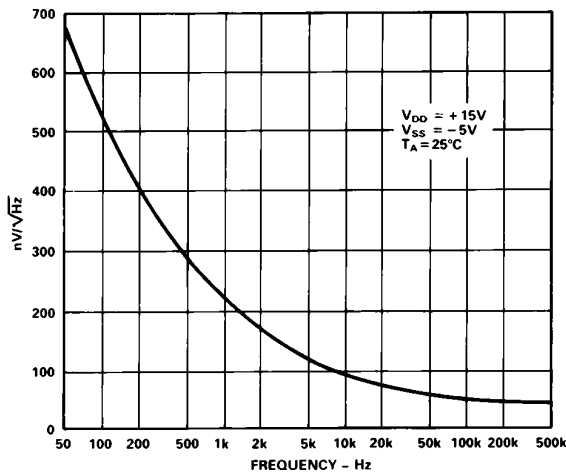

Figure 5. Noise Spectral Density vs. Frequency

DIGITAL INPUTS

The AD7228A digital inputs are compatible with either TTL or 5 V CMOS levels. All logic inputs are static-protected MOS gates with typical input currents of less than 1 nA. Internal input protection is achieved by on-chip distributed diodes.

SUPPLY CURRENT

The AD7228A has a maximum I_{DD} specification of 22 mA and a maximum I_{SS} of 20 mA over the -55°C to +125°C temperature range. This maximum current specification is actually determined by the current at -55°C. Figure 6 shows a typical plot of power supply current versus temperature.

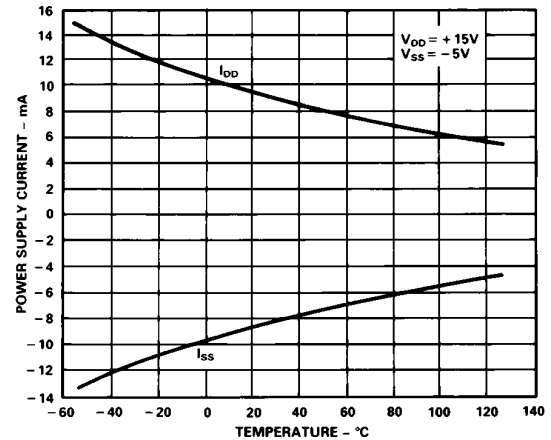

Figure 6. Power Supply Current vs. Temperature

APPLYING THIS AD7228A

UNIPOLAR OUTPUT OPERATION

This is the basic mode of operation for each channel of the AD7228A, with the output voltage having the same positive polarity as V_{REF}. Connections for unipolar output operation are shown in Figure 7. The AD7228A can be operated from single or dual supplies as outlined earlier. The voltage at the reference input must never be negative with respect to GND. Failure to observe this precaution may cause parasitic transistor action and possible device destruction. The code table for unipolar output operation is shown in Table II.

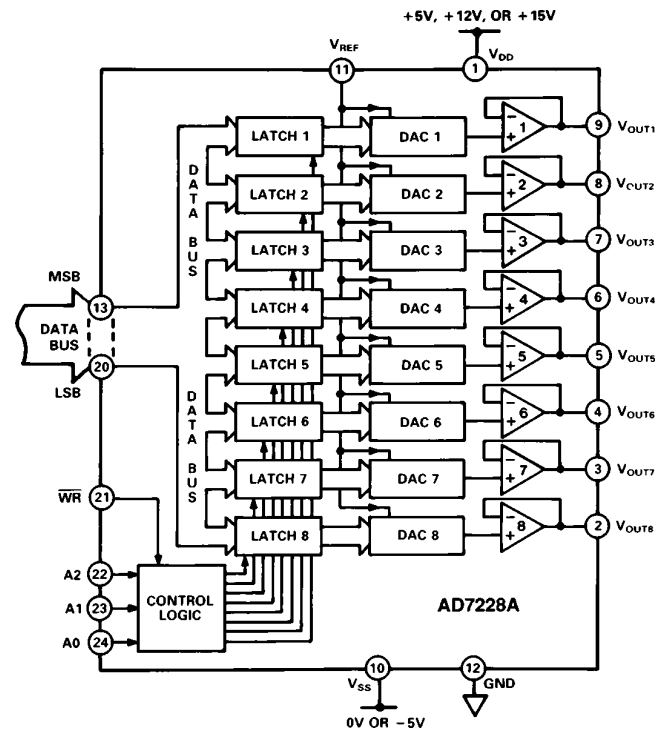

Figure 7. Unipolar Output Circuit

AD7228A

Table II. Unipolar Code Table

DAC Latch Contents MSB	LSB	Analog Output
1 1 1 1	1 1 1 1	$+V_{REF} \left(\frac{255}{256} \right)$
1 0 0 0	0 0 0 1	$+V_{REF} \left(\frac{129}{256} \right)$
1 0 0 0	0 0 0 0	$+V_{REF} \left(\frac{128}{256} \right) = +\frac{V_{REF}}{2}$
0 1 1 1	1 1 1 1	$+V_{REF} \left(\frac{127}{256} \right)$
0 0 0 0	0 0 0 1	$+V_{REF} \left(\frac{1}{256} \right)$
0 0 0 0	0 0 0 0	0 V

Note: 1 LSB = $(V_{REF})(2^{-8}) = V_{REF} \left(\frac{1}{256} \right)$

BIPOLAR OUTPUT OPERATION

Each of the DACs on the AD7228A can be individually configured for bipolar output operation. This is possible using one external amplifier and two resistors per channel. Figure 8 shows a circuit used to implement offset binary coding (bipolar operation) with DAC1 of the AD7228A. In this case

$$V_{OUT} = \left(1 + \frac{R2}{R1} \right) \cdot (D_1 \cdot V_{REF}) - \left(\frac{R2}{R1} \right) \cdot (V_{REF})$$

With $R1 = R2$

$$V_{OUT} = (2D_1 - 1) \cdot (V_{REF})$$

where D_1 is a fractional representation of the digital word in latch 1 of the AD7228A. ($0 \leq D_1 \leq 255/256$)

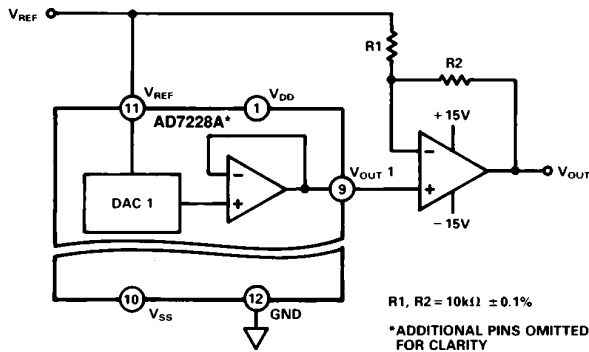

Figure 8. Bipolar Output Circuit

Table III. Bipolar Code Table

DAC Latch Contents MSB	LSB	Analog Output
1 1 1 1	1 1 1 1	$+V_{REF} \left(\frac{127}{128} \right)$
1 0 0 0	0 0 0 1	$+V_{REF} \left(\frac{1}{128} \right)$
1 0 0 0	0 0 0 0	0 V
0 1 1 1	1 1 1 1	$-V_{REF} \left(\frac{1}{128} \right)$
0 0 0 0	0 0 0 1	$-V_{REF} \left(\frac{127}{128} \right)$
0 0 0 0	0 0 0 0	$-V_{REF} \left(\frac{128}{128} \right) = -V_{REF}$

Mismatch between $R1$ and $R2$ causes gain and offset errors, and therefore, these resistors must match and track over temperature.

Once again, the AD7228A can be operated from single supply or from dual supplies. Table III shows the digital code versus output voltage relationship for the circuit of Figure 8 with $R1 = R2$.

AC REFERENCE SIGNAL

In some applications it may be desirable to have an ac signal applied as the reference input to the AD7228A. The AD7228A has multiplying capability within the upper (+10 V) and lower (+2 V) limits of reference voltage when operated with dual supplies. Therefore, ac signals need to be ac coupled and biased up before being applied to the reference input. Figure 9 shows a sine-wave signal applied to the reference input of the AD7228A. For input frequencies up to 50 kHz, the output distortion typically remains less than 0.1%. The typical 3 dB bandwidth for small signal inputs is 800 kHz.

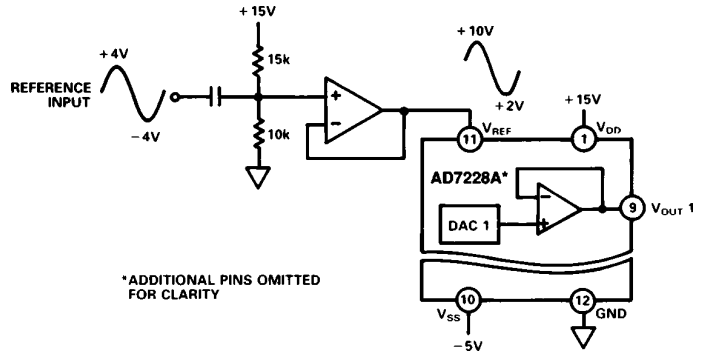

Figure 9. Applying a AC Signal to the AD7228A

TIMING DESKEW

A common problem in ATE applications is the slowing or "rounding-off" of signal edges by the time they reach the pin-driver circuitry. This problem can easily be overcome by "squaring-up" the edge at the pin-driver. However, since each edge will not have been "rounded-off" by the same extent, this "squaring-up" could lead to incorrect timing relationship between signals. This effect is shown in Figure 10a.

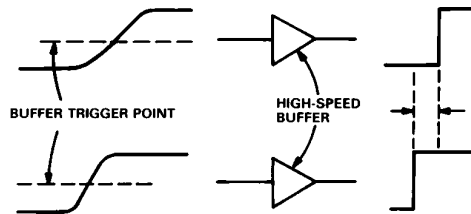

Figure 10a. Time Skewing Due to Slowing of Edges

The circuit of Figure 10b shows how two DACs of the AD7228A can help in overcoming this problem. The same two signals are applied to this circuit as were applied in Figure 10b. The output of each DAC is applied to one input of a high-speed comparator, and the signals are applied to the other inputs. Varying the output voltage of the DAC effectively varies the trigger point at which the comparator flips. Thus the timing relationship between the two signals can be programmably corrected (or deskewed) by varying the code to the DAC of the AD7228A. In a typical application, the code is loaded to the

DACs for correct timing relationships during the calibration cycle of the instrument.

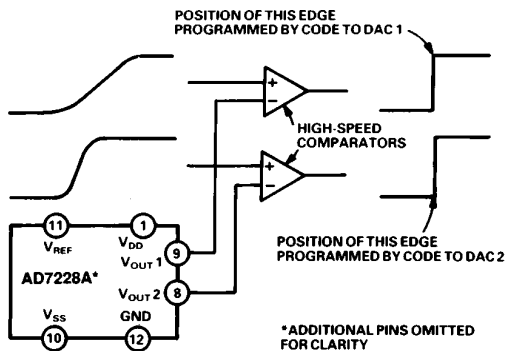

Figure 10b. AD7228A Timing Deskew Circuit

COARSE/FINE ADJUST

The DACs on the AD7228A can be paired together to form a coarse/fine adjust function as indicated in Figure 11. The function is achieved using one external op amp and a few resistors per pair of DACs.

DAC1 is the most significant or coarse DAC. Data is first loaded to this DAC to coarsely set the output voltage. DAC2 is then used to fine tune this output voltage. Varying the ratio of R1 to R2 varies the relative effect of the coarse and fine DACs on the output voltage. For the resistor values shown, DAC2 has a resolution of 150 μ V in a 10 V output range. Since each DAC on the AD7228A is guaranteed monotonic, the coarse adjustment and fine adjustment are each monotonic. One application for this is as a set-point controller (see "Circuit Applications of the AD7226 Quad CMOS DAC" available from Analog Devices, Publication Number E873-15-11/84).

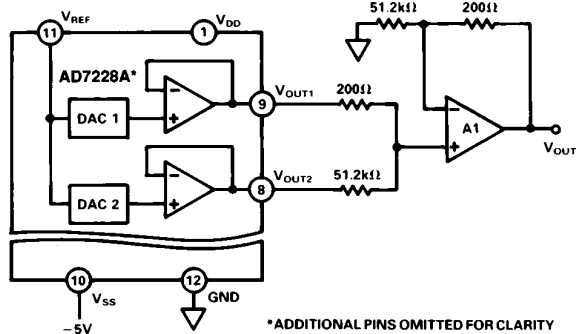

Figure 11. Coarse/Fine Adjust Circuit

SELF-PROGRAMMABLE REFERENCE

The circuit of Figure 12 shows how one DAC of the AD7228, in this case DAC1, may be used in a feedback configuration to provide a programmable reference for itself and the other seven converters. The relationship of V_{REF} to V_{IN} is expressed by

$$V_{REF} = \frac{(1 + G)}{(1 + G \cdot D_1)} \cdot V_{IN} \quad \text{where } G = R_2/R_1$$

Figure 13 shows typical plots of V_{REF} versus digital code, D_1 , for three different values of G. With $V_{IN} = 2.5$ V and $G = 3$ the voltage at the output varies between 2.5 V and 10 V giving an effective 10-bit dynamic range to the other seven converters. For correct operation of the circuit, V_{SS} should be -5 V and R_1 greater than 6.8 k Ω .

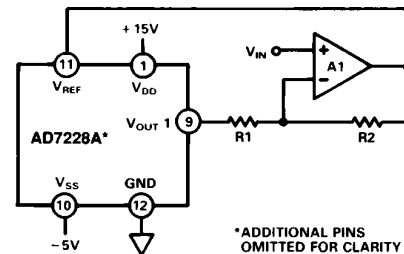

Figure 12. Self-Programmable Reference

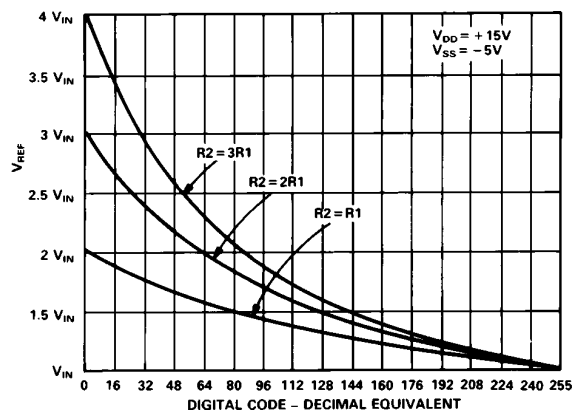

Figure 13. Variation of V_{REF} with Feedback Configuration

MICROPROCESSOR INTERFACING

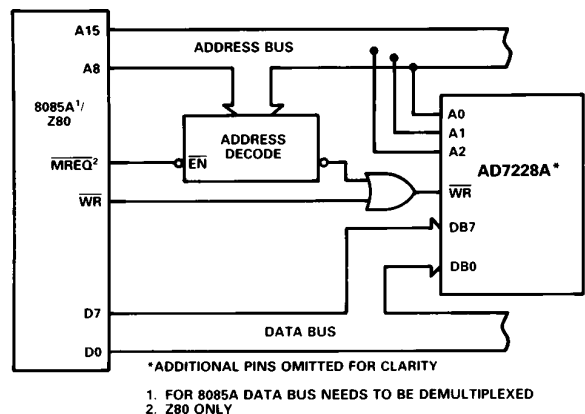

Figure 14. AD7228A to 8085A/Z80 Interface

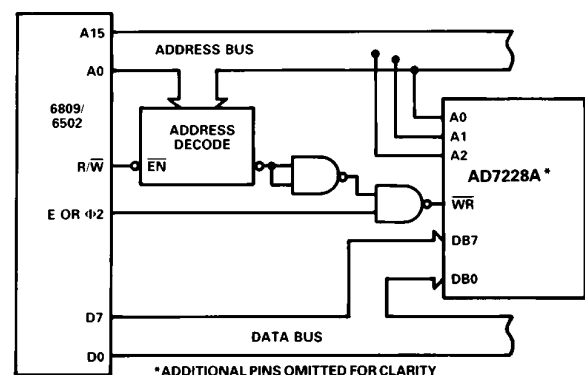

Figure 15. AD7228A to 6809/6502 Interface

AD7228A

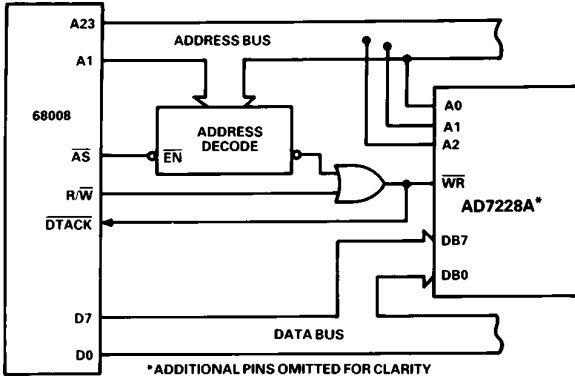

Figure 16. AD7228A to 68008 Interface

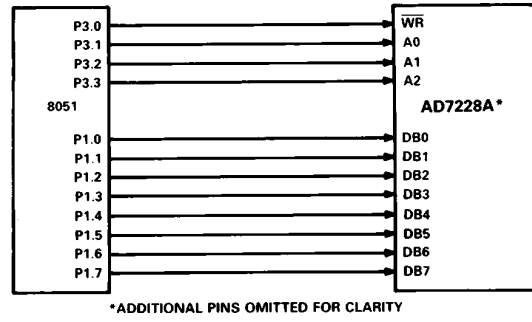
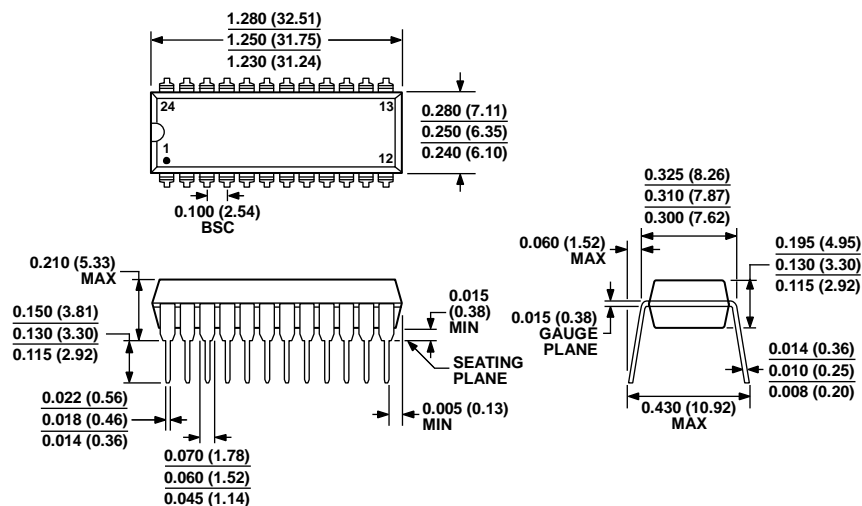

Figure 17. AD7228A to MCS-51 Interface

OUTLINE DIMENSIONS



COMPLIANT TO JEDEC STANDARDS MS-001
 CONTROLLING DIMENSIONS ARE IN INCHES; MILLIMETER DIMENSIONS (IN PARENTHESES) ARE ROUNDED-OFF INCH EQUIVALENTS FOR REFERENCE ONLY AND ARE NOT APPROPRIATE FOR USE IN DESIGN. CORNER LEADS MAY BE CONFIGURED AS WHOLE OR HALF LEADS.

Figure 18. 24-Lead Plastic Dual In-Line Package [PDIP]
 Narrow Body
 (N-24-1)
 Dimensions shown in inches and (millimeters)

071006-A

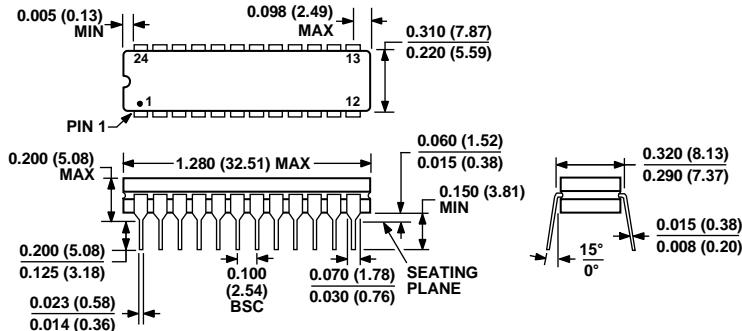

CONTROLLING DIMENSIONS ARE IN INCHES; MILLIMETER DIMENSIONS (IN PARENTHESES) ARE ROUNDED-OFF INCH EQUIVALENTS FOR REFERENCE ONLY AND ARE NOT APPROPRIATE FOR USE IN DESIGN.

Figure 19. 24-Lead Ceramic Dual In-Line Package [CERDIP]
 Narrow Body
 (Q-24-1)
 Dimensions shown in inches and (millimeters)

106806-A

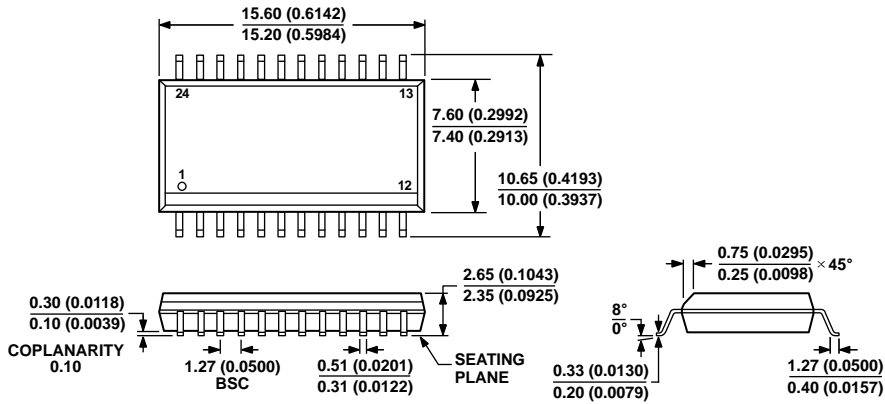

COMPLIANT TO JEDEC STANDARDS MS-013-AD
 CONTROLLING DIMENSIONS ARE IN MILLIMETERS; INCH DIMENSIONS
 (IN PARENTHESES) ARE ROUNDED-OFF MILLIMETER EQUIVALENTS FOR
 REFERENCE ONLY AND ARE NOT APPROPRIATE FOR USE IN DESIGN.

Figure 20. 24-Lead Standard Small Outline Package [SOIC_W]
 Wide Body
 (RW-24)

Dimensions shown in millimeters and (inches)

12-09-2010-A

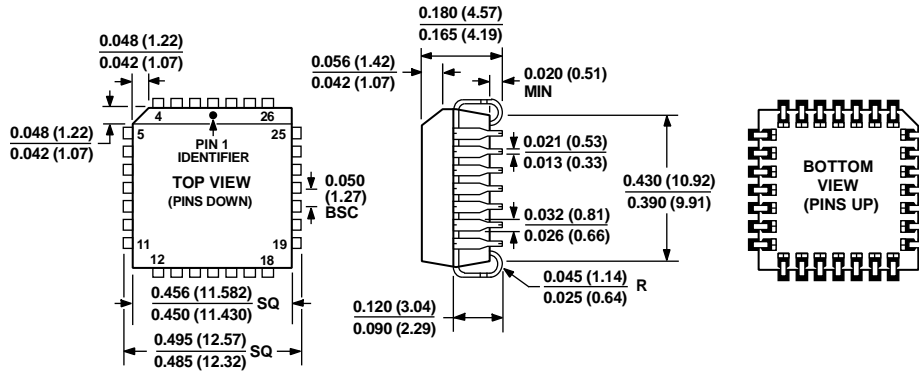

COMPLIANT TO JEDEC STANDARDS MO-047-AB
 CONTROLLING DIMENSIONS ARE IN INCHES; MILLIMETER DIMENSIONS
 (IN PARENTHESES) ARE ROUNDED-OFF INCH EQUIVALENTS FOR
 REFERENCE ONLY AND ARE NOT APPROPRIATE FOR USE IN DESIGN.

Figure 21. 28-Lead Plastic Leaded Chip Carrier [PLCC]
 (P-28)

Dimensions shown in inches and (millimeters)

042508-A

ORDERING GUIDE

Model ¹	Temperature Range	TUE (LSB)	Package Description	Package Option
AD7228ABN	-40°C to +85°C	±2 max	24-Lead PDIP	N-24-1
AD7228ABNZ	-40°C to +85°C	±2 max	24-Lead PDIP	N-24-1
AD7228ABPZ	-40°C to +85°C	±2 max	24-Lead PLCC	P-28
AD7228ABPZ-REEL	-40°C to +85°C	±2 max	24-Lead PLCC	P-28
AD7228ABR	-40°C to +85°C	±2 max	24-Lead SOIC_W	RW-24
AD7228ABRZ	-40°C to +85°C	±2 max	24-Lead SOIC_W	RW-24
AD7228ABRZ-REEL	-40°C to +85°C	±2 max	24-Lead SOIC_W	RW-24
AD7228ACN	-40°C to +85°C	±1 max	24-Lead PDIP	N-24-1
AD7228ACNZ	-40°C to +85°C	±1 max	24-Lead PDIP	N-24-1
AD7228ACP	-40°C to +85°C	±1 max	24-Lead PLCC	P-28
AD7228ACPZ	-40°C to +85°C	±1 max	24-Lead PLCC	P-28
AD7228ACPZ-REEL	-40°C to +85°C	±1 max	24-Lead PLCC	P-28
AD7228ACQ	-40°C to +85°C	±1 max	24-Lead Cerdip	Q-24-1
AD7228ACR	-40°C to +85°C	±1 max	24-Lead SOIC_W	RW-24
AD7228ACR-REEL	-40°C to +85°C	±1 max	24-Lead SOIC_W	RW-24
AD7228ACRZ	-40°C to +85°C	±1 max	24-Lead SOIC_W	RW-24
AD7228ACRZ-REEL	-40°C to +85°C	±1 max	24-Lead SOIC_W	RW-24

¹ Z = RoHS Compliant Part.

REVISION HISTORY**6/13—Rev. A to Rev. B**

Updated Outline Dimensions.....	9
Changes to Ordering Guide.....	11