

**Characteristics list**

Rated voltage (V)	Rated temperature (°C)	Category voltage (V)	Category temperature (°C)	Rated capacitance (µF)	Case size (mm)			Size code	Specifications				Standard		Floor life level	
					L	W	H		Ripple <sup>*1</sup> current (mA rms)	ESR <sup>*2</sup> (mΩ max.)	tan δ <sup>*3</sup>	LC <sup>*4</sup> (µA)	Part number	Min. packaging q'ty (pcs)	Reflow temp ≤260°C	Reflow temp ≤250°C
2.0	105	2.0	105	330	3.5	2.8	1.9	B2	2000	15	0.08	132.0	2TPE330MFB	2000	3	3
	85	1.8	105		3.5	2.8	1.9		2000	15	0.08	132.0	2TPE330MAFB	2000		
	85	1.8	105		3.5	2.8	1.9		2000	13/300kHz	0.10	132.0	2TPE330MADGB	2000		
	85	1.8	105	470	3.5	2.8	1.9		2300	15	0.10	188.0	2TPE470MAFB	2000		
	85	1.8	105		3.5	2.8	1.9		2300	11/300kHz	0.08	188.0	2TPE470MAJGB	2000		
2.5	85	2.0	105	220	3.5	2.8	1.9		2000	15	0.08	110.0	2R5TPE220MAFB	2000		
	105	2.5	105		3.5	2.8	1.9		1800	15/300kHz	0.08	110.0	2R5TPE220MFGB	2000		
	105	2.5	105		3.5	2.8	1.9		1700	21	0.08	55.0	2R5TPE220MLB	2000		
	85	2.0	105		3.5	2.8	1.9		1600	25	0.08	55.0	2R5TPE220MAPB	2000		
	105	2.5	105		3.5	2.8	1.9		1400	35	0.08	55.0	2R5TPE220MZB	2000		
	85	2.0	105	330	3.5	2.8	1.9		1400	35	0.08	55.0	2R5TPE220MAZB	2000		
	<b>NEW</b> 105	<b>2.5</b>	<b>105</b>		<b>3.5</b>	<b>2.8</b>	<b>1.9</b>		<b>1400</b>	<b>30</b>	<b>0.08</b>	<b>55.0</b>	<b>2R5TPE220MUB</b>	<b>2000</b>		
	85	2.0	105		3.5	2.8	1.9		1400	35	0.08	82.5	2R5TPE330MAZB	2000		
	85	2.0	105		3.5	2.8	1.9		3200	9/300kHz	0.08	165.0	ETPE330MA9GB	2000		
	105	2.5	105		3.5	2.8	1.9		3200	9/300kHz	0.08	165.0	ETPE330M9GB	2000		
	85	2.0	105	100	3.5	2.8	1.9		2700	15	0.08	165.0	ETPE330MAFB	2000		
	105	2.5	105		3.5	2.8	1.9		2700	15	0.08	165.0	ETPE330MFB	2000		
	<b>NEW</b> 105	<b>2.5</b>	<b>105</b>		<b>3.5</b>	<b>2.8</b>	<b>1.9</b>		<b>2450</b>	<b>18</b>	<b>0.08</b>	<b>165.0</b>	<b>ETPE330MIB</b>	<b>2000</b>		
	105	4.0	105		3.5	2.8	1.9		1400	35	0.08	40.0	4TPE100MZB	2000		
	<b>NEW</b> 105	<b>4.0</b>	<b>105</b>		<b>3.5</b>	<b>2.8</b>	<b>1.9</b>		<b>950</b>	<b>70</b>	<b>0.08</b>	<b>40.0</b>	<b>4TPE100MBB</b>	<b>2000</b>		
4.0	<b>NEW</b> 105	<b>4.0</b>	<b>105</b>	150	3.5	2.8	1.9	1300	40	0.08	40.0	4TPE100MWB	2000			
	85	3.2	105		3.5	2.8	1.9	1400	35	0.08	60.0	4TPE150MAZB	2000			
	85	3.2	105	220	3.5	2.8	1.9	1400	35	0.08	88.0	4TPE220MAZB	2000			
	<b>NEW</b> 105	<b>4.0</b>	<b>105</b>		3.5	2.8	1.9	1350	35	0.10	88.0	4TPE220MZB	2000			
	<b>NEW</b> 105	<b>4.0</b>	<b>105</b>		3.5	2.8	1.9	1150	45	0.10	88.0	4TPE220MVB	2000			
	<b>NEW</b> 105	<b>4.0</b>	<b>105</b>		3.5	2.8	1.9	950	70	0.10	88.0	4TPE220MBB	2000			
	105	6.3	105		3.5	2.8	1.9	1600	25	0.08	63.0	6TPE100MPB	2000			
6.3	85	5.0	105	100	3.5	2.8	1.9	1400	35	0.08	63.0	6TPE100MAZB	2000			
	105	6.3	105		3.5	2.8	1.9	1400	35	0.08	63.0	6TPE100MZB	2000			
	<b>NEW</b> 105	<b>6.3</b>	<b>105</b>		3.5	2.8	1.9	950	70	0.08	63.0	6TPE100MBB	2000			
	<b>NEW</b> 105	<b>6.3</b>	<b>105</b>		3.5	2.8	1.9	1300	40	0.08	63.0	6TPE100MWB	2000			
	<b>NEW</b> 105	<b>6.3</b>	<b>105</b>		3.5	2.8	1.9	1200	45	0.08	63.0	6TPE100MVB	2000			
	85	5.0	105	120	3.5	2.8	1.9	1400	35	0.08	75.6	6TPE120MAZB	2000			
	85	5.0	105		150	3.5	2.8	1.9	1600	25	0.08	94.5	6TPE150MAPB	2000		
	85	5.0	105			3.5	2.8	1.9	1400	35	0.08	94.5	6TPE150MAZB	2000		
	85	5.0	105			3.5	2.8	1.9	1400	35	0.10	138.6	6TPE220MAZB	2000		
	85	5.0	105		220	3.5	2.8	1.9	1600	25	0.10	138.6	6TPE220MAPB	2000		
	<b>NEW</b> 105	<b>6.3</b>	<b>105</b>	3.5		2.8	1.9	1150	45	0.10	138.6	6TPE220MVB	2000			
	<b>NEW</b> 105	<b>6.3</b>	<b>105</b>	3.5		2.8	1.9	950	70	0.10	138.6	6TPE220MBB	2000			
	<b>NEW</b> 105	<b>6.3</b>	<b>105</b>	3.5		2.8	1.9	1350	35	0.10	138.6	6TPE220MZB	2000			
	8.0	85	6.3	105		100	3.5	2.8	1.9	1400	35	0.08	80.0	8TPE100MAZB	2000	
	10	85	8.0	105	47	3.5	2.8	1.9	1400	35	0.08	47.0	10TPE47MAZB	2000		

\*1: Ripple current (100 kHz / +45 °C) \*2: ESR (100 kHz / +20 °C) \*3: tan δ (120 Hz / +20 °C) \*4: After 5 minutes  
 ♦ Please refer to each page in this catalog for "Reflow conditions", "Taping specifications" and "Floor life level".  
 ♦ Small order quantity (500 pcs/reel) is available with TPE series. Please contact our sales representative if you prefer it.

**Surface Mount Type**

TPE series D size



**Features**

- Low profile (Height 1.5 mm max.)
- Low ESR (7 mΩ max.)
- Large capacitance (1500 μF max.)
- RoHS compliance, Halogen free

**Specifications**

Size code	D15E	D2E	D3L	D4
Category temp. range	-55 °C to +105 °C			
Rated volt. range	6.3 V	2.5 V to 10 V		
Category volt. range	5.0 V	2.5 V to 10 V		
Rated cap. range	470 μF	68 μF to 470 μF	150 μF to 680 μF	330 μF to 1500 μF
Capacitance tolerance	±20 % (120 Hz / +20 °C)			
Leakage current	Please see the attached characteristics list			
Dissipation factor(tan δ)	Please see the attached characteristics list			
Surge voltage (V)	Rated voltage × 1.15			
Endurance	+105 °C 2000 h rated voltage applied Rated temp, +85 °C Products : +85 °C 1000 h, rated voltage applied 6TPE330MAP, 6TPE470MAZU : +85 °C 2000 h, rated voltage applied			
	Capacitance change	Within ±20 % of the initial value		
	Dissipation factor(tan δ)	≤ 1.5 times of the initial limit		
	Leakage current	Within the initial limit		
Damp heat (Steady State)	+60 °C, 90 % to 95 % RH, 500 h, No-applied voltage			
	Capacitance change	Within +50 %, -20 % of the initial value (2R5TPE220M (I, F, 9), 2R5TPE330M (I, F, C, 9, 7), 2R5TPE470M (I, F, C, 9, 7), 2R5TPE1000MF, 2R5TPE1500M (F, C)) Within +40 %, -20 % of the initial value (Except for above model)		
	Dissipation factor(tan δ)	≤ 1.5 times of the initial limit		
	Leakage current	≤ 3 times of the initial limit		

**Marking**

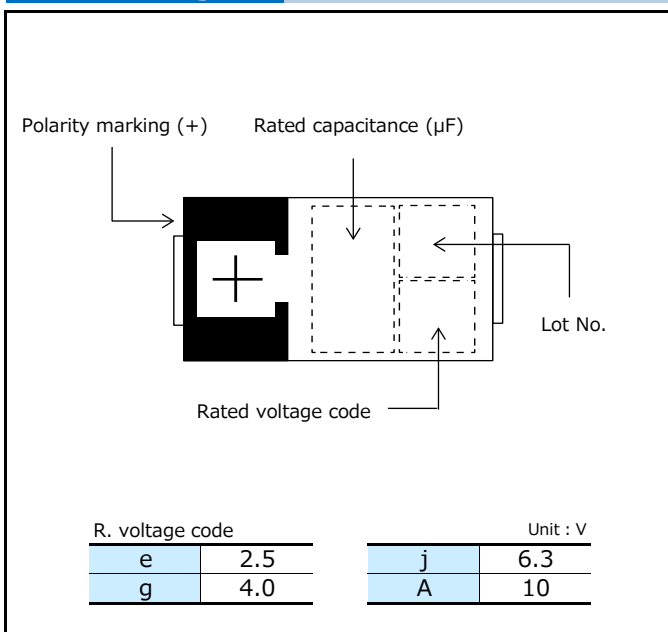

**Dimensions (not to scale)**

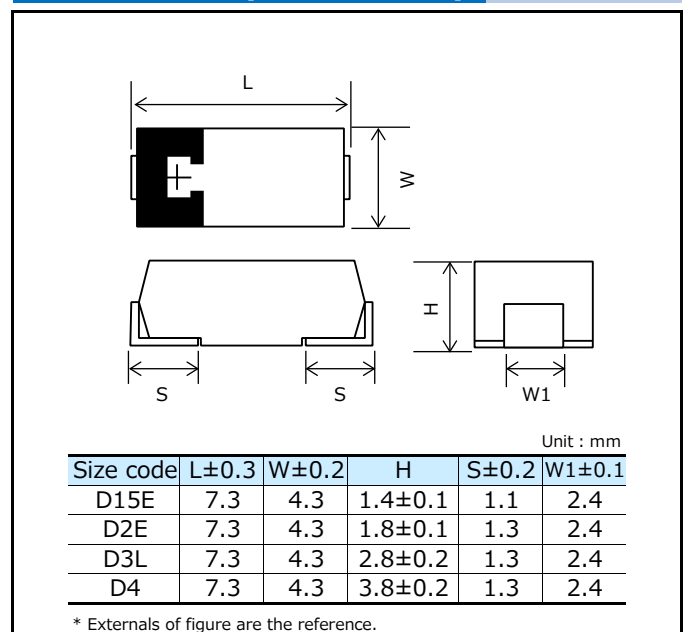

**Characteristics list**

Rated voltage (V)	Rated temperature (°C)	Category voltage (V)	Category temperature (°C)	Rated capacitance (µF)	Case size (mm)			Size code	Specifications				Standard		Floor life level						
					L	W	H		Ripple current <sup>*1</sup> (mA rms)	ESR <sup>*2</sup> (mΩ max.)	tan δ <sup>*3</sup>	LC <sup>*4</sup> (µA)	Part number	Min. packaging qty (pcs)	Reflow temp ≤260°C	Reflow temp ≤250°C					
2.5	105	2.5	105	220	7.3	4.3	1.8	D2E	3900	9	0.10	55.0	2R5TPE220M9	3000	3						
	105	2.5	105		7.3	4.3	1.8		3100	15	0.10	55.0	2R5TPE220MF	3000							
	105	2.5	105		7.3	4.3	1.8		2800	18	0.10	55.0	2R5TPE220MI	3000							
	105	2.5	105		7.3	4.3	1.8		2400	25	0.10	55.0	2R5TPE220M	3000							
	105	2.5	105		7.3	4.3	1.8		4400	7	0.10	82.5	2R5TPE330M7	3000							
	105	2.5	105		7.3	4.3	1.8		3900	9	0.10	82.5	2R5TPE330M9	3000							
	105	2.5	105	330	7.3	4.3	1.8	D2E	3500	12	0.10	82.5	2R5TPE330MC	3000							
	105	2.5	105		7.3	4.3	1.8		3100	15	0.10	82.5	2R5TPE330MF	3000							
	105	2.5	105		7.3	4.3	1.8		2800	18	0.10	82.5	2R5TPE330MI	3000							
	105	2.5	105		7.3	4.3	1.8		2400	25	0.10	82.5	2R5TPE330M	3000							
	105	2.5	105		7.3	4.3	1.8		4400	7	0.10	117.5	2R5TPE470M7	3000							
	105	2.5	105		7.3	4.3	1.8		3900	9	0.10	117.5	2R5TPE470M9	3000							
	105	2.5	105	470	7.3	4.3	1.8	D2E	3500	12	0.10	117.5	2R5TPE470MC	3000							
	105	2.5	105		7.3	4.3	1.8		3100	15	0.10	117.5	2R5TPE470MI	3000							
	105	2.5	105		7.3	4.3	1.8		2800	18	0.10	117.5	2R5TPE470M	3000							
	105	2.5	105		7.3	4.3	1.8		2400	25	0.10	117.5	2R5TPE470MI	3000							
	105	2.5	105		7.3	4.3	2.8		3500	12	0.10	170.0	2R5TPE680MCL	2500							
	105	2.5	105		7.3	4.3	2.8		3100	15	0.10	170.0	2R5TPE680MFL	2500							
105	2.5	105	680	7.3	4.3	2.8	D3L	1850	40	0.10	170.0	2R5TPE680MWL	2500								
NEW 105	2.5	105		7.3	4.3	2.8		3900	15	0.15	250.0	2R5TPE1000MF	2000								
105	2.5	105	1000	7.3	4.3	3.8	D4	4400	12	0.15	375.0	2R5TPE1500MC	2000								
105	2.5	105	1500	7.3	4.3	3.8		3900	15	0.15	375.0	2R5TPE1500MF	2000								
4.0	105	4.0	105	150	7.3	4.3	1.8	D2E	2800	18	0.10	60.0	4TPE150MI	3000	3	2a					
	105	4.0	105		7.3	4.3	1.8		3100	15	0.10	88.0	4TPE220MF	3000							
	105	4.0	105		7.3	4.3	1.8		2800	18	0.10	88.0	4TPE220MI	3000							
	105	4.0	105	220	7.3	4.3	1.8		D2E	2400	25	0.10	88.0	4TPE220M			3000				
	NEW 105	4.0	105		7.3	4.3	1.8			1750	45	0.10	88.0	4TPE220MV			3000				
	105	4.0	105		7.3	4.3	1.8			2800	18	0.10	132.0	4TPE330MI			3000				
	105	4.0	105	330	7.3	4.3	1.8		D2E	2400	25	0.10	132.0	4TPE330M			3000				
	NEW 105	4.0	105		7.3	4.3	1.8			1850	40	0.10	132.0	4TPE330MW			3000				
	105	4.0	105		7.3	4.3	2.8			3500	12	0.10	188.0	4TPE470MCL			2500				
	105	4.0	105	470	7.3	4.3	2.8		D3L	3100	15	0.10	188.0	4TPE470MFL			2500				
	105	4.0	105		7.3	4.3	2.8			2800	18	0.10	188.0	4TPE470MIL			2500				
	105	4.0	105		7.3	4.3	2.8			2400	25	0.10	188.0	4TPE470ML			2500				
	NEW 105	4.0	105	680	7.3	4.3	2.8		D3L	1850	40	0.10	188.0	4TPE470MWL			2500				
	6.3	105	6.3	105	100	7.3	4.3		1.8	D2E	2800	18	0.10	63.0			6TPE100MI	3000	3		
		105	6.3	105		7.3	4.3		1.8		2400	25	0.10	63.0			6TPE100M	3000			
		NEW 105	6.3	105		7.3	4.3		1.8		1850	40	0.10	63.0			6TPE100MW	3000			
		105	6.3	105	150	7.3	4.3		1.8		D2E	3100	15	0.10			94.5	6TPE150MF			3000
		105	6.3	105		7.3	4.3		1.8			2800	18	0.10			94.5	6TPE150MI			3000
105		6.3	105	7.3		4.3	1.8	2400	25			0.10	94.5	6TPE150M	3000						
105		6.3	105	220	7.3	4.3	1.8	D2E	2800		18	0.10	138.6	6TPE220MI	3000						
105		6.3	105		7.3	4.3	1.8		2400		25	0.10	138.6	6TPE220M	3000						
105		6.3	105		7.3	4.3	1.8		2400		25	0.10	138.6	6TPE220MAP	3000						
NEW 105		6.3	105	680	7.3	4.3	1.8	D3L	1850		40	0.10	138.6	6TPE220MW	3000						
NEW 105		6.3	105	85	7.3	4.3	2.8	D3L	2800		18	0.10	138.6	6TPE220MIL	2500						
85		5.0	105	330	7.3	4.3	1.8	D2E	2400		25	0.10	207.9	6TPE330MAP	3000						
85		5.0	105		7.3	4.3	2.8		2400		25	0.10	207.9	6TPE330MAL	2500						
85		5.0	105		7.3	4.3	2.8		3900		9/500kHz	0.10	207.9	6TPE330MA9EL	2500						
105		6.3	105	470	7.3	4.3	2.8	D3L	3100		15	0.10	207.9	6TPE330MFL	2500						
105		6.3	105		7.3	4.3	2.8		2800		18	0.10	207.9	6TPE330MIL	2500						
105		6.3	105		7.3	4.3	2.8		2400		25	0.10	207.9	6TPE330ML	2500						
85		5.0	105	680	7.3	4.3	3.8	D4	4400		10	0.10	207.9	6TPE330MAA	2000						
85	5.0	105	7.3		4.3	1.4	D15E		1700	35	0.10	296.1	6TPE470MAZU	4000							
105	6.3	105	7.3		4.3	3.8	3500		18	0.15	296.1	6TPE470MI	2000								
105	6.3	105	880	7.3	4.3	3.8	D4	3000	25	0.15	296.1	6TPE470M	2000								
NEW 105	6.3	105		7.3	4.3	3.8		2500	35	0.15	296.1	6TPE470MZ	2000								
NEW 105	6.3	105		7.3	4.3	3.8		2350	40	0.15	296.1	6TPE470MW	2000								
105	6.3	105	1000	7.3	4.3	3.8	D4	3500	18	0.15	428.4	6TPE680MI	2000								
105	6.3	105		7.3	4.3	3.8		3000	25	0.15	428.4	6TPE680M	2000								
105	10	105		7.3	4.3	1.8		D2E	2400	25	0.10	68.0	10TPE68M	3000							
NEW 105	10	105	68	7.3	4.3	1.8	D2E	1850	40	0.10	68.0	10TPE68MW	3000								
NEW 105	10	105	150	7.3	4.3	2.8	D2E	2400	25	0.10	150.0	10TPE150MPL	2500								
105	10	105	220	7.3	4.3	2.8	D3L	2800	18	0.10	220.0	10TPE220MIL	2500								
105	10	105		7.3	4.3	2.8		2400	25	0.10	220.0	10TPE220ML	2500								
105	10	105		7.3	4.3	3.8		D4	3000	25	0.10	330.0	10TPE330M	2000							

\*1: Ripple current (100 kHz / +45 °C) \*2: ESR (100 kHz / +20 °C) \*3: tan δ (120 Hz / +20 °C) \*4: After 5 minutes

◆ Please refer to each page in this catalog for "Reflow conditions", "Taping specifications" and "Floor life level".

◆ Small order quantity (500 pcs/reel) is available with TPE series. Please contact our sales representative if you prefer it.

## Guidelines and precautions regarding the technical information and use of our products described in this online catalog.

- If you want to use our products described in this online catalog for applications requiring special qualities or reliability, or for applications where the failure or malfunction of the products may directly jeopardize human life or potentially cause personal injury (e.g. aircraft and aerospace equipment, traffic and transportation equipment, combustion equipment, medical equipment, accident prevention, anti-crime equipment, and/or safety equipment), it is necessary to verify whether the specifications of our products fit to such applications. Please ensure that you will ask and check with our inquiry desk as to whether the specifications of our products fit to such applications use before you use our products.
- The quality and performance of our products as described in this online catalog only apply to our products when used in isolation. Therefore, please ensure you evaluate and verify our products under the specific circumstances in which our products are assembled in your own products and in which our products will actually be used.
- If you use our products in equipment that requires a high degree of reliability, regardless of the application, it is recommended that you set up protection circuits and redundancy circuits in order to ensure safety of your equipment.
- The products and product specifications described in this online catalog are subject to change for improvement without prior notice. Therefore, please be sure to request and confirm the latest product specifications which explain the specifications of our products in detail, before you finalize the design of your applications, purchase, or use our products.
- The technical information in this online catalog provides examples of our products' typical operations and application circuits. We do not guarantee the non-infringement of third party's intellectual property rights and we do not grant any license, right, or interest in our intellectual property.
- If any of our products, product specifications and/or technical information in this online catalog is to be exported or provided to non-residents, the laws and regulations of the exporting country, especially with regard to security and export control, shall be observed.

## <Regarding the Certificate of Compliance with the EU RoHS Directive/REACH Regulations>

- The switchover date for compliance with the RoHS Directive/REACH Regulations varies depending on the part number or series of our products.
- When you use the inventory of our products for which it is unclear whether those products are compliant with the RoHS Directive/REACH Regulation, please select "Sales Inquiry" in the website inquiry form and contact us.

**We do not take any responsibility for the use of our products outside the scope of the specifications, descriptions, guidelines and precautions described in this online catalog.**

## Notices

### ■ Applicable laws and regulations

- This product complies with the RoHS Directive (Restriction of the use of certain hazardous substances in electrical and electronic equipment (DIRECTIVE 2011/65/EU and (EU)2015/863)).
- No Ozone Depleting Chemicals(ODC's), controlled under the Montreal Protocol Agreement, are used in producing this product.  
We do not use PBBs or PBDEs as brominated flame retardants.
- Export procedure which followed export related regulations, such as foreign exchange and a foreign trade method, on the occasion of export of this product.
- These products are not dangerous goods on the transportation as identified by UN(United Nations) numbers or UN classification.

### ■ Limited applications

- This capacitor is designed to be used for electronics circuits such as audio/visual equipment, home appliances, computers and other office equipment, optical equipment, measuring equipment.
- Prior to usage of this capacitor for applications requiring high reliability and safety and malfunction of capacitor might threaten human life or property, it is highly recommended to confirm the usage of this capacitors with Panasonic.

### ■ Intellectual property rights and licenses

- The technical information in this specification provides examples of our products' typical operations and application circuits. We do not guarantee the non-infringement of third party's intellectual property rights and we do not grant any license, right, or interest in our intellectual property.

## Items to be observed

### ■ For specification

- This specification guarantees the quality and performance of the product as individual components. The durability differs depending on the environment and the conditions of usage. Before use, check and evaluate their compatibility with actual conditions when installed in the products. When safety requirements cannot be satisfied in your technical examination, inform us immediately.
- Do not use the products beyond the specifications described in this document.

### ■ Upon application to products where safety is regarded as important

Install the following systems for a failsafe design to ensure safety if these products are to be used in equipment where a defect in these products may cause the loss of human life or other signification damage, such as damage to vehicles (automobile, train, vessel), traffic lights, medical equipment, aerospace equipment, electric heating appliances, combustion/ gas equipment, rotating rotating equipment, and disaster/crime prevention equipment.

- (1) The system is equipped with a protection circuit and protection device.
- (2) The system is equipped with a redundant circuit or other system to prevent an unsafe status in the event of a single fault.

### ■ Conditions of use

- Before using the products, carefully check the effects on their quality and performance, and determined whether or not they can be used. These products are designed and manufactured for general-purpose and standard use in general electronic equipment. These products are not intended for use in the following special conditions.
  - (1) In liquid, such as Water, Oil, Chemicals, or Organic solvent.
  - (2) In direct sunlight, outdoors, or in dust.
  - (3) In vapor, such as dew condensation water of resistive element, or water leakage, salty air, or air with a high concentration corrosive gas, such as Cl<sub>2</sub>, H<sub>2</sub>S, NH<sub>3</sub>, SO<sub>2</sub>, or NO<sub>x</sub>.
  - (4) In an environment where strong static electricity or electromagnetic waves exist.
  - (5) Mounting or placing heat-generating components or inflammables, such as vinyl-coated wires, near these products.
  - (6) Sealing or coating of these products or a printed circuit board on which these products are mounted, with resin and other material.
  - (7) Using resolvent, water or water-soluble cleaner for flux cleaning agent after soldering. (In particular, when using water or a water-soluble cleaning agent, be careful not to leave water residues)
  - (8) Using in the atmosphere where strays acid or alkaline.
  - (9) Using in the atmosphere where there are excessive vibration and shock.
  - (10) Using in the atmosphere where there are low pressure or decompression.
- Please arrange circuit design for preventing impulse or transitional voltage.  
Do not apply voltage, which exceeds the full rated voltage when the capacitors receive impulse voltage, instantaneous high voltage, high pulse voltage etc.
- Our products there is a product are using an electrolyte solution. Therefore, misuse can result in rapid deterioration of characteristics and functions of each product. Electrolyte leakage damages printed circuit and affects performance, characteristics, and functions of customer system.

## ⚠ Guidelines and precautions (POSCAP)

### 1. Circuit design

#### 1.1 Prohibited circuits

Since problems can be expected, POSCAP cannot be used on the following circuits.

- (1) High impedance voltage retention circuits
- (2) Coupling circuit
- (3) Time constant circuits
- (4) Circuits greatly affected by leakage current
- (5) The circuit in which two or more POSCAP are connected in a series so as to raise the endurance voltage.

#### 1.2 Failure and life-span

The failure rate is 0.5 %\* / 1000 h (Confidence level : 60 %) based on JIS C 5003.

The mainly failure modes are as follows.

\* B2 size or less : 1.0 %

##### 1.2-1 Contingency failure

The main causes of failure are thermal stresses cause by the soldering or thermal use environment, along with heat stresses, electrical stresses or mechanical stresses. The most common failure mode is a short circuit. In case a short circuit occurs, ensure safety by fully considering the followings.

- (a) If POSCAP emit smoke, turn off the main power of the equipment. In this case, keep your face and hands away from the area.
- (b) It may take a few seconds to a few minutes before POSCAP emits smoke by the situation. Increase safety by using a protective circuit.
- (c) If the smoke comes into eyes, rinse immediately. If the smoke is inhaled, gargle immediately.
- (d) In case a large current continues to flow after a short circuit, in the worst case, the shorted-out section may ignite. For safety, install a redundant circuit or a protective circuit, etc.

##### 1.2-2 Wear-out failure (lifetime)

When lifetime exceeded the specified guarantee time of Endurance and Damp heat, electrolyte might insulate and cause electric characteristic changed. This is called an open circuit. The rated capacitance values and the electrical characteristics values such as ESR specified in the characteristics list are factory default values. Please carefully design a circuit since rated capacitance values and the electrical characteristics values may change (increase) beyond the specified values under the conditions of rated voltage/temperature and electrical/mechanical performances.

#### 1.3 Reduction of failure stress

When POSCAP is used within the rated voltage, it shows a stable characteristic, but it may be damaged in a short circuit when an overvoltage, for instance, is applied. The time to reach the failure mode can be extended by using POSCAP with reduced environment temperature, ripple current and applied voltage.

Failure rate

- In the case of the endurance which is 105 °C 2000 h.  
0.5 %/1000 h (Environment temp. : 105 °C, Rated voltage or Category voltage applied)
- In the case of the endurance which is 105 °C 1000 h or 125 °C 1000 h.  
1.0 %/1000 h (Environment temp. : 105 °C, Rated voltage or Category voltage applied)
- In the case of the endurance which is 85 °C 1000 h.  
1.0 %/1000 h (Environment temp. : 85 °C, Rated voltage applied)

#### 1.4 Check the rated performance

After checking the operation and installation environments, design the circuit so that it falls within the rated performance range stipulated in this delivery specification.

#### 1.5 Operating temperature and ripple current

- (1) Set the operating temperature so that it falls within the range stipulated in this delivery specification.
- (2) Do not apply current that exceeds the allowable ripple current. Ripple current should be controlled so that surface temperature of a capacitor do not exceed the rated temperature.  
(For questions regarding TQC series, please contact us.)
- (3) The ESR values specified in the characteristics list are factory default values.  
ESR values may change (increase) beyond the specified values depending on the customer's use conditions.



### 1.6 Leakage current

Even when the soldering conditions fall within the range of this delivery specifications, leakage current increases a little on occasion. It also increases a little during high temperature storage, high humidity storage and temperature cycling with no voltage applied. In cases such as these, leakage current will decrease by applying voltage under the condition of below the POSCAP's maximum operating temperature. The speed at which the leakage current is restored is increased by applying voltage when the POSCAP's temperature is close to the maximum operating temperature.

### 1.7 Rapid charge and discharge limitation

Rapid charge and discharge are restricted (for maintainance of high-proof reliability).

A protective circuit is recommended for when a rapid charge or discharge causes excessive rush current since this is main cause of short circuit and large leakage current. Use a protective circuits in case the rush current value exceeds 20 A\*.

Be sure to insert a protection resistor of about 1 kΩ for charge and discharge when measuring the leakage current.

\* When TH series use under the ambient temperature more than 105 °C : 10 A, TPU series : 10 A

## 2. Mounting

### 2.1 Protect circuit

The failure mode of POSCAP is the short mode. When it breaks down, short electric current flows to it. POSCAP gives off heat by this short current.

Do the following consideration in design fully for the safety because it has a bad influence on the part around POSCAP due to this heat.

- A protective circuit and a protective device are set up, so as to make the system safer.
- A diffuse circuit and so on is set up, so as to make the system safer such as that a machine may not break down as to the single trouble.

### 2.2 Considerations when soldering

The soldering conditions are to be within the range prescribed in this delivery specification.

If the specifications are not followed, there is the possibility of degradation of electric characteristic and lifetime when soldering is conducted under conditions that are harsher than those stipulated.

### 2.3 Others

POSCAP's Electrical characteristics are affected by temperature and frequency fluctuations.

Design circuits after checking the amount of fluctuation.

## 3. Storage

It is necessary to set an environment to prevent a trouble at the time of soldering by the degradation of solder ability or moisture's getting into the molding resin when POSCAP are stored.

- Please make storage of POSCAP sealing up in the reel and storage bag at the time of delivery in the following environment. Also, set storage period of unopened as 18 months or shorter after shipment from factory.
  - Room temperature and room humidity (generally : 15 to 35 °C, 45 to 75% RH ) are desirable.
  - Place where POSCAP is not exposed by direct sunshine.
- Please unseal storage bag just before mounting and use up POSCAP in the storage bag.

Floor life		
Level	Time	Conditions
2a	4 weeks	≤ 30 °C / 60 %RH
3	168 hours	≤ 30 °C / 60 %RH
5	48 hours	≤ 30 °C / 60 %RH

POSCAP is not compatible with JEDEC J-STD-020, J-STD-033

### \* Intellectual property right

We, Panasonic Group are providing the product and service that customers can use without anxiety, and are working positively on the protection of our products under intellectual property rights.

Representative patents relating to POSCAP are as follows:

US Patent No.6508800, No.6891717, No.7158368, No.7326260号, No.8081421, No.8149569, No.8456804, No.8559166