

FIG 2
1.50 LEAD STYLE
ST4-40-1.50-X-D SHOWN
(DIFFERENT AS SHOWN, OTHERWISE SAME AS FIG 1)

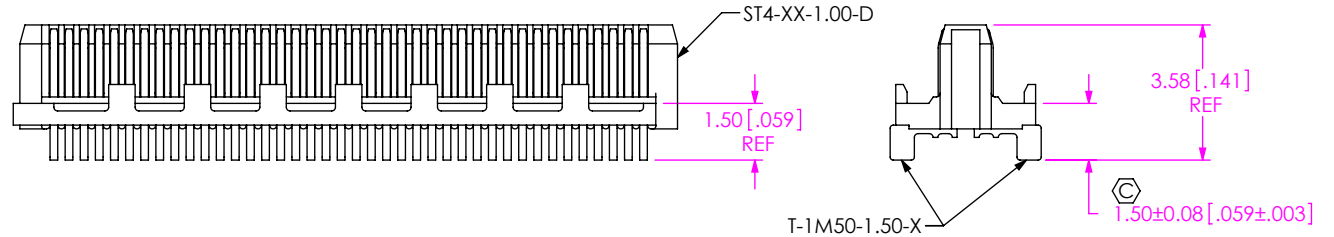
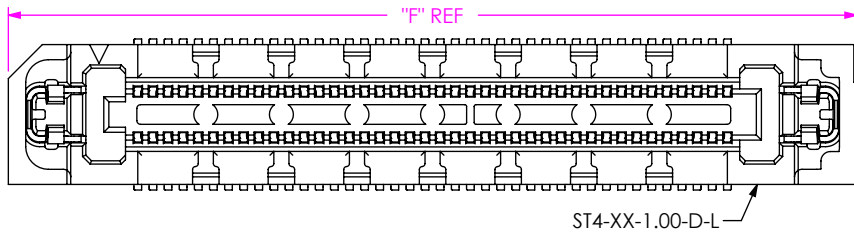
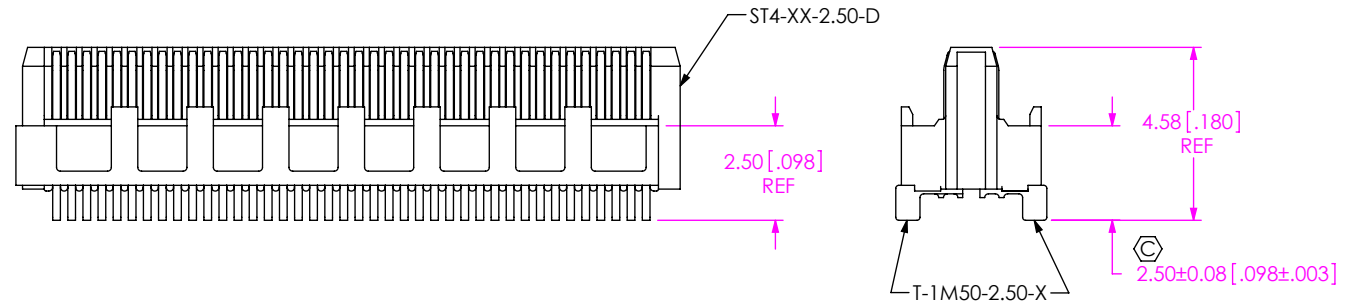
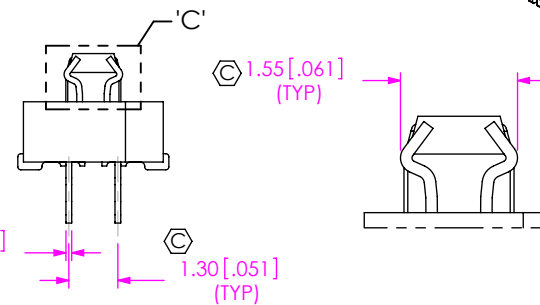
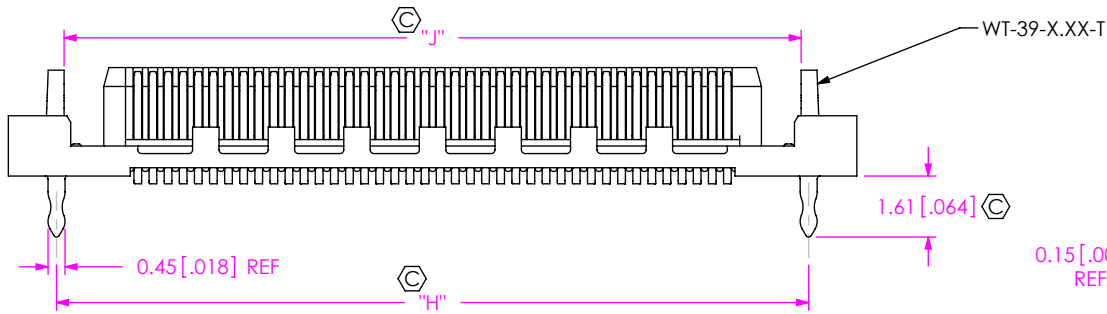
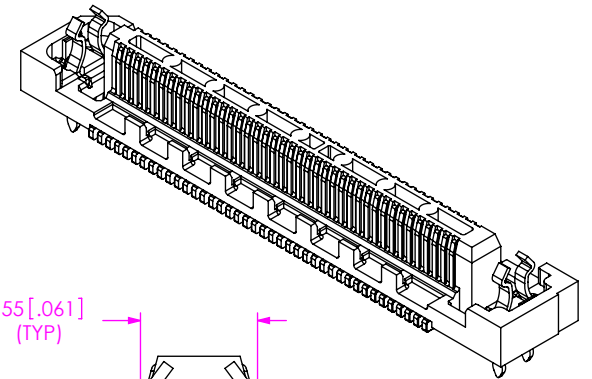

FIG 3
2.50 LEAD STYLE
ST4-40-2.50-X-D SHOWN
(DIFFERENT AS SHOWN, OTHERWISE SAME AS FIG 1)



LEAD STYLE	LATCH
-1.00	WT-39-1.00-T
-1.50	WT-39-1.50-T
-2.50	WT-39-2.50-T

TOOLED FOR -1.00 LEAD STYLE ONLY



No. OF POS	"F"	"H"	"J"
-10	10.46 [0.412]	7.90 [0.311]	7.50 [0.295]
-15	12.46 [0.491]	9.90 [0.390]	9.50 [0.374]
-20	14.46 [0.569]	11.90 [0.469]	11.50 [0.453]
-30	18.46 [0.727]	15.90 [0.626]	15.50 [0.610]
-40	22.46 [0.884]	19.90 [0.783]	19.50 [0.768]
-50	26.46 [1.042]	23.90 [0.941]	23.50 [0.925]

FIG 5
**-L: LATCHING OPTION
ST4-40-1.00-X-D-L SHOWN
(DIFFERENT AS SHOWN, OTHERWISE SAME AS FIG 1)
** = AVAILABLE FOR EXISTING CUSTOMERS ONLY

PROPRIETARY NOTE
THIS DOCUMENT CONTAINS CONFIDENTIAL AND PROPRIETARY INFORMATION AND ALL DESIGN, MANUFACTURING, REPRODUCTION, USE, PATENT RIGHTS AND SALES RIGHTS ARE EXPRESSLY RESERVED BY SAMTEC, INC. THIS DOCUMENT SHALL NOT BE DISCLOSED, IN WHOLE OR PART, TO ANY UNAUTHORIZED PERSON OR ENTITY NOR REPRODUCED, TRANSFERRED OR INCORPORATED IN ANY OTHER PROJECT IN ANY MANNER WITHOUT THE EXPRESS WRITTEN CONSENT OF SAMTEC, INC.

DO NOT SCALE DRAWING

SHEET SCALE: 5:1



520 PARK EAST BLVD, NEW ALBANY, IN 47150
PHONE: 812-944-6733 FAX: 812-948-5047
e-Mail info@SAMTEC.com code 55322

DESCRIPTION:
0.4mm [.016] TERMINAL STRIP ASSEMBLY

DWG. NO.
ST4-XX-X.XX-X-D-X-XX-TR

BY: BRATCHER 3/21/2007 SHEET 2 OF 4

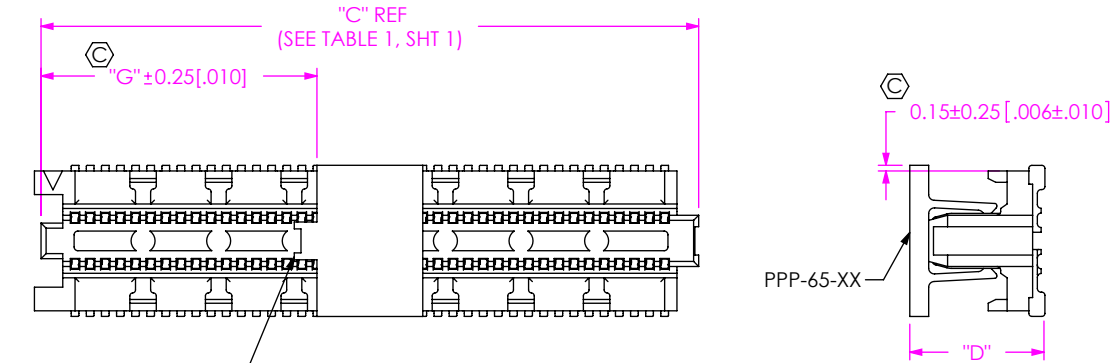

NOTCH OF PPP-65-XX TO FACE POS 1 END

FIG 7
-P: PICK AND PLACE PAD OPTION
ST4-40-1.00-X-D-P SHOWN
(DIFFERENT AS SHOWN, OTHERWISE SAME AS FIG 1)

LEAD STYLE	"D"
-1.00	3.55 [0.140]
-1.50	4.05 [0.159]
-2.50	5.05 [0.199]

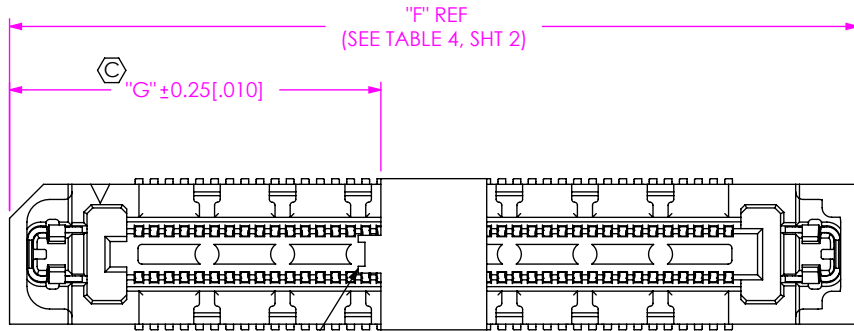

NOTCH OF PPP-65-XX TO FACE POS 1 END

FIG 8
-P: PICK AND PLACE PAD (W/ LATCH OPTION)
ST4-40-1.00-X-D-L-P SHOWN
(DIFFERENT AS SHOWN, OTHERWISE SAME AS FIG 1)

No. OF POS	"G" WITH NO - L OPTION	"G" WITH - L OPTION
-10	1.30 [0.051]	3.83 [0.151]
*-15	2.30 [0.091]	4.83 [0.190]
-20	3.30 [0.130]	5.83 [0.230]
-30	5.30 [0.209]	7.83 [0.308]
-40	7.30 [0.287]	9.83 [0.387]
-50	9.30 [0.366]	11.83 [0.466]

* = NOT TOOLED FOR LEAD STYLE 2.50

PROPRIETARY NOTE
THIS DOCUMENT CONTAINS CONFIDENTIAL AND PROPRIETARY INFORMATION AND ALL DESIGN, MANUFACTURING, REPRODUCTION, USE, PATENT RIGHTS AND SALES RIGHTS ARE EXPRESSLY RESERVED BY SAMTEC, INC. THIS DOCUMENT SHALL NOT BE DISCLOSED, IN WHOLE OR PART, TO ANY UNAUTHORIZED PERSON OR ENTITY NOR REPRODUCED, TRANSFERRED OR INCORPORATED IN ANY OTHER PROJECT IN ANY MANNER WITHOUT THE EXPRESS WRITTEN CONSENT OF SAMTEC, INC.

DO NOT SCALE DRAWING

SHEET SCALE: 5:1

samtec

520 PARK EAST BLVD, NEW ALBANY, IN 47150
PHONE: 812-944-6733 FAX: 812-948-5047
e-Mail info@SAMTEC.com code 55322

DESCRIPTION:
0.4mm[.016] TERMINAL STRIP ASSEMBLY

DWG. NO.
ST4-XX-X.XX-X-D-X-XX-TR

BY: BRATCHER 3/21/2007 SHEET 3 OF 4

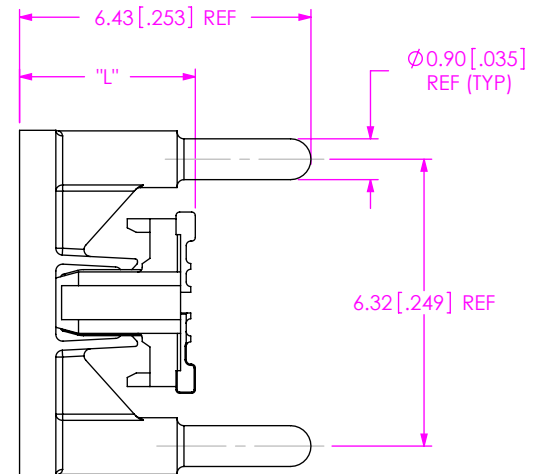
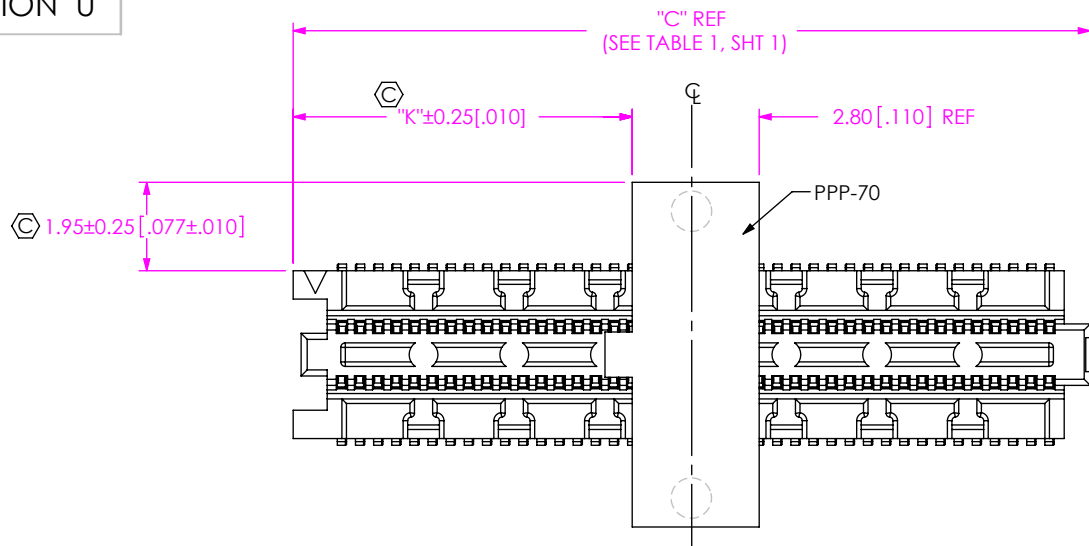

FIG 9
 **-PA: PICK & PLACE WITH ALIGNMENT PINS
 ST4-40-1.00-X-D-PA SHOWN
 (DIFFERENT AS SHOWN, OTHERWISE SAME AS FIG 1)
 ** = AVAILABLE FOR EXISTING CUSTOMERS ONLY

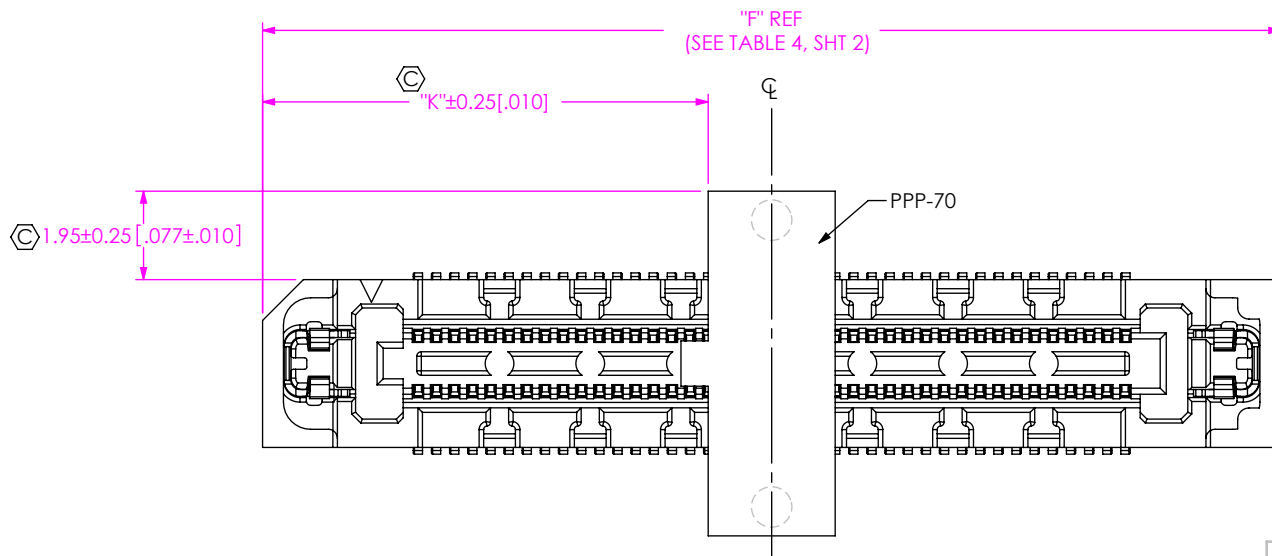

FIG 10
 **-PA: PICK & PLACE WITH ALIGNMENT PINS (WITH -L OPTION)
 ST4-40-1.00-X-D-L-PA SHOWN
 (DIFFERENT AS SHOWN, OTHERWISE SAME AS FIG 1)
 ** = AVAILABLE FOR EXISTING CUSTOMERS ONLY

POS	"K" W/O -L OPTION	"K" W/ -L OPTION
-10	1.300 [0.051]	3.830 [0.151]
-20	3.300 [0.130]	5.830 [0.230]
-30	5.300 [0.209]	7.830 [0.308]
-40	7.300 [0.287]	9.830 [0.387]
-50	9.300 [0.366]	11.830 [0.466]

LEAD STYLE	"L"
-1.00	3.58 [0.141]
-1.50	4.08 [0.161]
-2.50	5.08 [0.200]

PROPRIETARY NOTE
 THIS DOCUMENT CONTAINS CONFIDENTIAL AND PROPRIETARY INFORMATION AND ALL DESIGN, MANUFACTURING, REPRODUCTION, USE, PATENT RIGHTS AND SALES RIGHTS ARE EXPRESSLY RESERVED BY SAMTEC, INC. THIS DOCUMENT SHALL NOT BE DISCLOSED, IN WHOLE OR PART, TO ANY UNAUTHORIZED PERSON OR ENTITY NOR REPRODUCED, TRANSFERRED OR INCORPORATED IN ANY OTHER PROJECT IN ANY MANNER WITHOUT THE EXPRESS WRITTEN CONSENT OF SAMTEC, INC.

DO NOT SCALE DRAWING

SHEET SCALE: 5:1



520 PARK EAST BLVD, NEW ALBANY, IN 47150
 PHONE: 812-944-6733 FAX: 812-948-5047
 e-Mail info@SAMTEC.com code 5322

DESCRIPTION:
 0.4mm[.016] TERMINAL STRIP ASSEMBLY

DWG. NO.
ST4-XX-X.XX-X-D-X-XX-TR

BY: BRATCHER 3/21/2007 SHEET 4 OF 4