

**PROTECTION PRODUCTS**
**Absolute Maximum Rating**

Rating	Symbol	Value	Units
Peak Pulse Power (tp = 8/20μs)	P <sub>pk</sub>	300	Watts
Lead Soldering Temperature	T <sub>L</sub>	260 (10 sec.)	°C
Operating Temperature	T <sub>J</sub>	-55 to +125	°C
Storage Temperature	T <sub>STG</sub>	-55 to +150	°C

**Electrical Characteristics**

<b>SMDA05C-7</b>						
Parameter	Symbol	Conditions	Minimum	Typical	Maximum	Units
Reverse Stand-Off Voltage	V <sub>RWM</sub>				5	V
Reverse Breakdown Voltage	V <sub>BR</sub>	I <sub>t</sub> = 1mA	6			V
Reverse Leakage Current	I <sub>R</sub>	V <sub>RWM</sub> = 5V, T=25°C			20	μA
Clamping Voltage	V <sub>C</sub>	I <sub>PP</sub> = 1A, tp = 8/20μs			9.8	V
Maximum Peak Pulse Current	I <sub>PP</sub>	tp = 8/20μs			17	A
Junction Capacitance	C <sub>J</sub>	Between I/O Pins and Ground V <sub>R</sub> = 0V, f = 1MHz			350	pF

<b>SMDA12C-7</b>						
Parameter	Symbol	Conditions	Minimum	Typical	Maximum	Units
Reverse Stand-Off Voltage	V <sub>RWM</sub>				12	V
Reverse Breakdown Voltage	V <sub>BR</sub>	I <sub>t</sub> = 1mA	13.3			V
Reverse Leakage Current	I <sub>R</sub>	V <sub>RWM</sub> = 12V, T=25°C			1	μA
Clamping Voltage	V <sub>C</sub>	I <sub>PP</sub> = 1A, tp = 8/20μs			19	V
Maximum Peak Pulse Current	I <sub>PP</sub>	tp = 8/20μs			12	A
Junction Capacitance	C <sub>J</sub>	Between I/O Pins and Ground V <sub>R</sub> = 0V, f = 1MHz			120	pF

**PROTECTION PRODUCTS**
**Electrical Characteristics (Continued)**

<b>SMDA15C-7</b>						
<b>Parameter</b>	<b>Symbol</b>	<b>Conditions</b>	<b>Minimum</b>	<b>Typical</b>	<b>Maximum</b>	<b>Units</b>
Reverse Stand-Off Voltage	$V_{RWM}$				15	V
Reverse Breakdown Voltage	$V_{BR}$	$I_t = 1mA$	16.7			V
Reverse Leakage Current	$I_R$	$V_{RWM} = 15V, T=25^\circ C$			1	$\mu A$
Clamping Voltage	$V_C$	$I_{PP} = 1A, tp = 8/20\mu s$			24	V
Maximum Peak Pulse Current	$I_{PP}$	$tp = 8/20\mu s$			10	A
Junction Capacitance	$C_j$	Between I/O Pins and Ground $V_R = 0V, f = 1MHz$			75	pF

<b>SMDA24C-7</b>						
<b>Parameter</b>	<b>Symbol</b>	<b>Conditions</b>	<b>Minimum</b>	<b>Typical</b>	<b>Maximum</b>	<b>Units</b>
Reverse Stand-Off Voltage	$V_{RWM}$				24	V
Reverse Breakdown Voltage	$V_{BR}$	$I_t = 1mA$	26.7			V
Reverse Leakage Current	$I_R$	$V_{RWM} = 24V, T=25^\circ C$			1	$\mu A$
Clamping Voltage	$V_C$	$I_{PP} = 1A, tp = 8/20\mu s$			43	V
Maximum Peak Pulse Current	$I_{PP}$	$tp = 8/20\mu s$			5	A
Junction Capacitance	$C_j$	Between I/O Pins and Ground $V_R = 0V, f = 1MHz$			50	pF

## PROTECTION PRODUCTS

### Typical Characteristics

#### Non-Repetitive Peak Pulse Power vs. Pulse Time

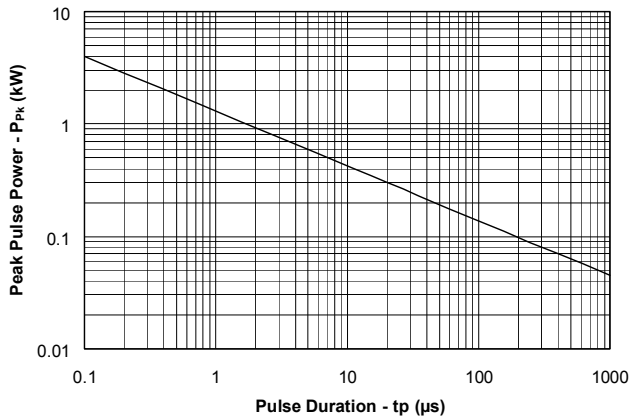

#### Power Derating Curve

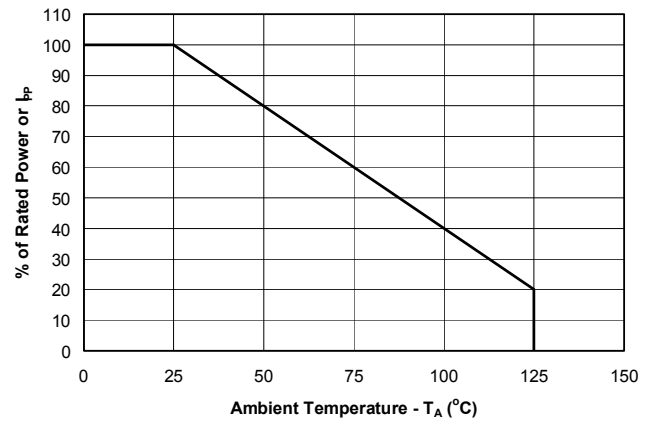

#### Pulse Waveform

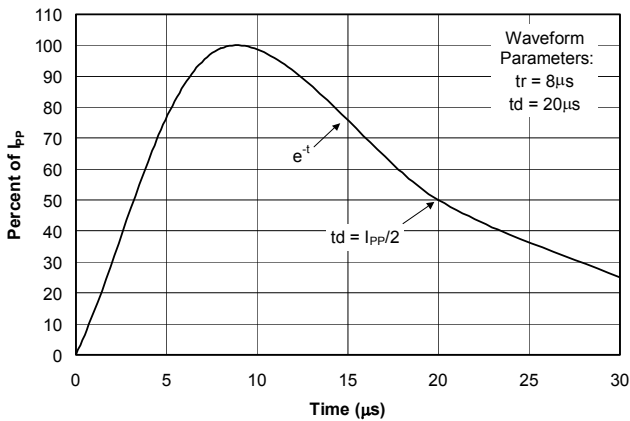

#### ESD Pulse Waveform (IEC 61000-4-2)

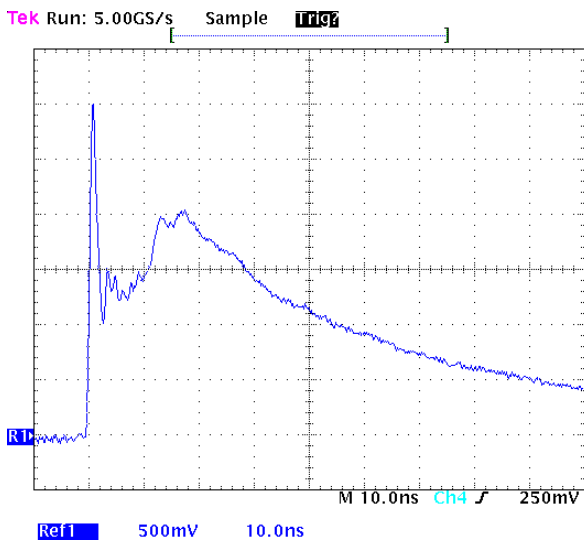

#### IEC 61000-4-2 Discharge Parameters

Level	First Peak Current (A)	Peak Current at 30 ns (A)	Peak Current at 60 ns (A)	Test Voltage (Contact Discharge) (kV)	Test Voltage (Air Discharge) (kV)
1	7.5	4	8	2	2
2	15	8	4	4	4
3	22.5	12	6	6	8
4	30	16	8	8	15

## PROTECTION PRODUCTS

### Applications Information

#### Device Connection for Protection of Seven Data Lines

The SMDAxxC-7 is designed to protect up to 7 data or I/O lines. They are bidirectional devices and may be used on lines where the signal polarities are above and below ground.

The SMDAxxC-7 TVS arrays employ a monolithic structure. Therefore, the working voltage ( $V_{RWM}$ ) and breakdown voltage ( $V_{BR}$ ) specifications apply to the differential voltage between any two data line pins. For example, the SMDA24C-7 is designed for a maximum voltage excursion of  $\pm 12V$  between any two data lines.

The device is connected as follows:

- Pins 1, 2, 3, 4, 5, 6 and 7 are connected to the lines that are to be protected. Pin 8 is connected to ground. The ground connections should be made directly to the ground plane for best results. The path length is kept as short as possible to reduce the effects of parasitic inductance in the board traces.

#### Circuit Board Layout Recommendations for Suppression of ESD.

Good circuit board layout is critical for the suppression of ESD induced transients. The following guidelines are recommended:

- Place the TVS near the input terminals or connectors to restrict transient coupling.
- Minimize the path length between the TVS and the protected line.
- Minimize all conductive loops including power and ground loops.
- The ESD transient return path to ground should be kept as short as possible.
- Never run critical signals near board edges.
- Use ground planes whenever possible.

**Circuit Diagram**

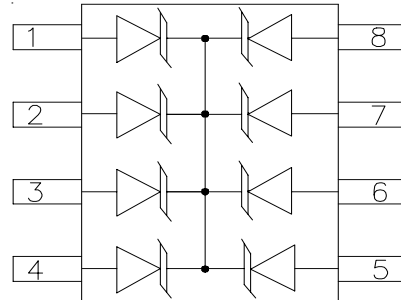

**Connection Diagram**

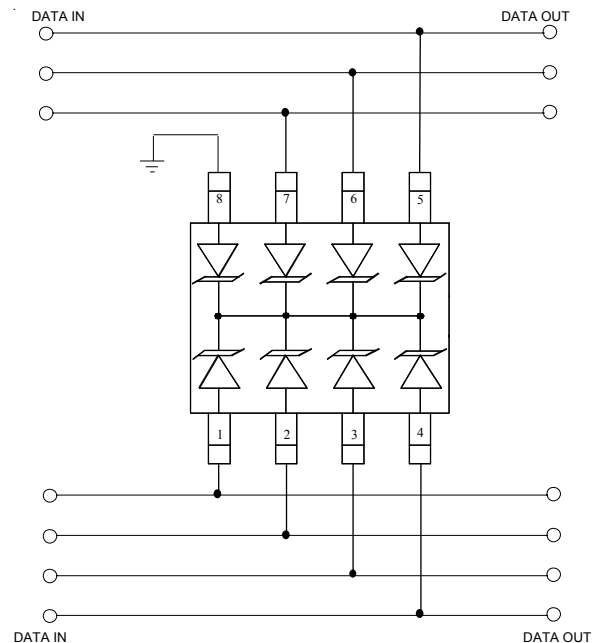

## PROTECTION PRODUCTS

### Outline Drawing - S0-8

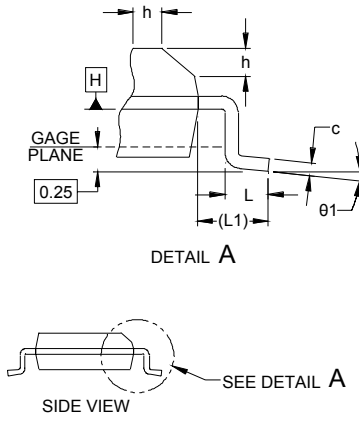
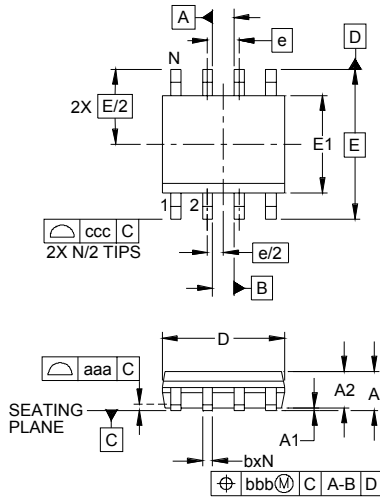

DIM	DIMENSIONS					
	INCHES			MILLIMETERS		
	MIN	NOM	MAX	MIN	NOM	MAX
A	.053	-	.069	1.35	-	1.75
A1	.004	-	.010	0.10	-	0.25
A2	.049	-	.065	1.25	-	1.65
b	.012	-	.020	0.31	-	0.51
c	.007	-	.010	0.17	-	0.25
D	.189	.193	.197	4.80	4.90	5.00
E1	.150	.154	.157	3.80	3.90	4.00
E	.236 BSC			6.00 BSC		
e	.050 BSC			1.27 BSC		
h	.010	-	.020	0.25	-	0.50
L	.016	.028	.041	0.40	0.72	1.04
L1	(0.041)			(1.04)		
N	8			8		
theta1	0°	-	8°	0°	-	8°
aaa	.004			0.10		
bbb	.010			0.25		
ccc	.008			0.20		

**NOTES:**

1. CONTROLLING DIMENSIONS ARE IN MILLIMETERS (ANGLES IN DEGREES).
2. DATUMS **-A-** AND **-B-** TO BE DETERMINED AT DATUM PLANE **-H-**
3. DIMENSIONS "E1" AND "D" DO NOT INCLUDE MOLD FLASH, PROTRUSIONS OR GATE BURRS.
4. REFERENCE JEDEC STD MS-012, VARIATION AA.

### Land Pattern - S0-8

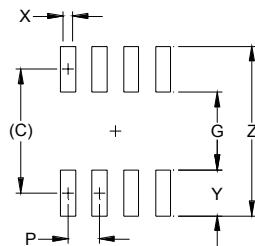

DIM	DIMENSIONS	
	INCHES	MILLIMETERS
C	(.205)	(5.20)
G	.118	3.00
P	.050	1.27
X	.024	0.60
Y	.087	2.20
Z	.291	7.40

**NOTES:**

1. THIS LAND PATTERN IS FOR REFERENCE PURPOSES ONLY. CONSULT YOUR MANUFACTURING GROUP TO ENSURE YOUR COMPANY'S MANUFACTURING GUIDELINES ARE MET.
2. REFERENCE IPC-SM-782A, RLP NO. 300A.

## PROTECTION PRODUCTS

### Ordering Information

Part Number	Lead Finish	Qty per Reel	Reel Size
SMDA05C-7.TB	SnPb	500	7 Inch
SMDA12C-7.TB	SnPb	500	7 Inch
SMDA15C-7.TB	SnPb	500	7 Inch
SMDA24C-7.TB	SnPb	500	7 Inch
SMDA05C-7.TBT	Pb Free	500	7 Inch
SMDA12C-7.TBT	Pb Free	500	7 Inch
SMDA15C-7.TBT	Pb Free	500	7 Inch
SMDA24C-7.TBT	Pb Free	500	7 Inch
SMDA05C-7	SnPb	95/Tube	N/A
SMDA12C-7	SnPb	95/Tube	N/A
SMDA15C-7	SnPb	95/Tube	N/A
SMDA24C-7	SnPb	95/Tube	N/A
SMDA05C-7.T	Pb Free	95/Tube	N/A
SMDA12C-7.T	Pb Free	95/Tube	N/A
SMDA15C-7.T	Pb Free	95/Tube	N/A
SMDA24C-7.T	Pb Free	95/Tube	N/A

Note: Lead-free devices are RoHS/WEEE Compliant

### Contact Information

Semtech Corporation  
 Protection Products Division  
 200 Flynn Road, Camarillo, CA 93012  
 Phone: (805)498-2111 FAX (805)498-3804