

Quad, Low-Voltage, SPST Analog Switches with Enable

ABSOLUTE MAXIMUM RATINGS

Voltages Referenced to GND

V+	-0.3V to +13.0V
V-	-13.0V to +0.3V
V+ to V-	-0.3V to +13.0V
All Other Pins (Note 1)	(V- - 0.3V) to (V+ + 0.3V)
Continuous Current into Any Terminal	±10mA
Peak Current into Any Terminal (pulsed at 1ms, 10% duty cycle)	±20mA
ESD per Method 3015.7	>2000V

Continuous Power Dissipation (T_A = +70°C) (Note 2)

Plastic DIP (derate 10.53mW/°C above +70°C)	842mW
Narrow SO (derate 8.70mW/°C above +70°C)	696mW
QSOP (derate 8.00mW/°C above +70°C)	800mW
Operating Temperature Ranges	
MAX453_C_E	0°C to +70°C
MAX453_E_E	-40°C to +85°C
Storage Temperature Range	-65°C to +150°C
Lead Temperature (soldering, 10sec)	+300°C

Note 1: Signals on NC₋, NO₋, COM₋, $\overline{\text{EN}}$, or IN₋ exceeding V₊ or V₋ are clamped by internal diodes. Limit forward-diode current to maximum current rating.

Note 2: All leads are soldered or welded to PC boards.

Stresses beyond those listed under "Absolute Maximum Ratings" may cause permanent damage to the device. These are stress ratings only, and functional operation of the device at these or any other conditions beyond those indicated in the operational sections of the specifications is not implied. Exposure to absolute maximum rating conditions for extended periods may affect device reliability.

ELECTRICAL CHARACTERISTICS—±5V Dual Supplies

(V₊ = 4.5V to 5.5V, V₋ = -4.5V to -5.5V, V_{INH} = 2.4V, V_{INL} = 0.8V, V_{EN} = 0.8V, T_A = T_{MIN} to T_{MAX}, unless otherwise noted. Typical values are at T_A = +25°C.)

PARAMETER	SYMBOL	CONDITIONS	T _A	MIN	TYP (Note 3)	MAX	UNITS
ANALOG SWITCH							
Analog Signal Range	V _{COM_-} , V _{NO_-} , V _{NC}	(Note 4)	C, E	V-		V+	V
COM ₋ NO ₋ , COM ₋ NC ₋ On-Resistance	R _{ON}	V ₊ = 4.5V, V ₋ = -4.5V, V _{COM_-} = 3.5V, I _{COM_-} = 1mA	+25°C C, E		55 100	100 125	Ω
COM ₋ NO ₋ , COM ₋ NC ₋ On-Resistance Match Between Channels (Note 5)	ΔR _{ON}	V ₊ = 4.5V, V ₋ = -4.5V, V _{COM_-} = 3.5V, I _{COM_-} = 1mA	+25°C C, E		1 6	4 6	Ω
COM ₋ NO ₋ , COM ₋ NC ₋ On-Resistance Flatness (Note 6)	R _{FLAT(ON)}	V ₊ = 5.0V, V ₋ = -5.0V, V _{COM_-} = -3.0V, 0, +3.0V, I _{COM_-} = 1mA	+25°C C, E		4 15	10 15	Ω
NO ₋ , NC ₋ Off-Leakage Current (Note 7)	I _{NO_(OFF)} , I _{NC_(OFF)}	V ₊ = 5.5V, V ₋ = -5.5V, V _{COM_-} = ±4.5V, V _{N_-} = ∓4.5V	+25°C C, E	-1 -10	0.01 10	1 10	nA
COM ₋ Off-Leakage Current (Note 7)	I _{COM_(OFF)}	V ₊ = 5.5V, V ₋ = -5.5V, V _{COM_-} = ±4.5V, V _{N_-} = ∓4.5V	+25°C C, E	-1 -10	0.01 10	1 10	nA
COM ₋ On-Leakage Current (Note 7)	I _{COM_(ON)}	V ₊ = 5.5V, V ₋ = -5.5V, V _{COM_-} = ±4.5V, V _{N_-} = ±4.5V	+25°C C, E	-2 -20	0.01 20	2 20	nA
LOGIC INPUT							
$\overline{\text{EN}}$, IN ₋ Input Logic Threshold High	V _{INH}		C, E		1.4	2.4	V
$\overline{\text{EN}}$, IN ₋ Input Logic Threshold Low	V _{INL}		C, E	0.8	1.4		V
$\overline{\text{EN}}$, IN ₋ Input Current Logic High or Low	I _{INH} , I _{INL}	V _{IN_-} = 0.8V or 2.4V	C, E	-1	0.03	1	μA

Quad, Low-Voltage, SPST Analog Switches with Enable

MAX4536/MAX4537/MAX4538

ELECTRICAL CHARACTERISTICS—±5V Dual Supplies (continued)

(V+ = 4.5V to 5.5V, V- = -4.5V to -5.5V, VINH = 2.4V, VINL = 0.8V, VEN = 0.8V, TA = TMIN to TMAX, unless otherwise noted. Typical values are at TA = +25°C.)

PARAMETER	SYMBOL	CONDITIONS	TA	MIN	TYP (Note 3)	MAX	UNITS
SWITCH DYNAMIC CHARACTERISTICS							
Turn-On Time	tON	VCOM_ = ±3V, V+ = 4.5V, V- = -4.5V (Figure 1)	+25°C	35	100		ns
			C, E			125	
Turn-Off Time	tOFF	VCOM_ = ±3V, V+ = 4.5V, V- = -4.5V (Figure 1)	+25°C	15	50		ns
			C, E			60	
Break-Before-Make Time Delay (MAX4538 Only)	tBBM	VCOM_ = ±3V, V+ = 5.5V, V- = -5.5V (Figure 2)	+25°C	5	15		ns
Charge Injection (Figure 3)	Q	CL = 1.0nF, VNO_ = 0V, RS = 0Ω	+25°C		1	5	pC
NO_, NC_ Off-Capacitance (Figure 6)	CN_(OFF)	VNO_ = GND, f = 1MHz	+25°C		2		pF
COM_ Off-Capacitance (Figure 6)	CCOM_(OFF)	VCOM_ = GND, f = 1MHz	+25°C		2		pF
COM_ On-Capacitance (Figure 7)	CCOM_(ON)	VCOM_ = VNO_ = GND, f = 1MHz	+25°C		6		pF
Off-Isolation (Note 8, Figure 4)	VISO	RL = 50Ω, CL = 15pF, VN_ = 1VRMS, f = 1MHz	+25°C		-65		dB
Channel-to-Channel Crosstalk (Note 9, Figure 5)	VCT	RL = 50Ω, CL = 15pF, VN_ = 1VRMS, f = 1MHz	+25°C		-75		dB
POWER SUPPLY							
Power-Supply Range	V+, V-		C, E	-6		6	V
V+ Supply Current	I+	V+ = 5.5V, all VIN_ = 0V or V+	+25°C	-1	0.05	1	μA
			C, E			10	
V- Supply Current	I-	V- = -5.5V	+25°C	-1	0.05	1	μA
			C, E			10	

Quad, Low-Voltage, SPST Analog Switches with Enable

MAX4536/MAX4537/MAX4538

ELECTRICAL CHARACTERISTICS—+5V Single Supply

($V_+ = 4.5V$ to $5.5V$, $V_- = 0V$, $V_{INH} = 2.4V$, $V_{INL} = 0.8V$, $V_{EN} = 0.8V$, $T_A = T_{MIN}$ to T_{MAX} , unless otherwise noted. Typical values are at $T_A = +25^\circ C$.)

PARAMETER	SYMBOL	CONDITIONS	T_A	MIN	TYP (Note 3)	MAX	UNITS
ANALOG SWITCH							
Analog Signal Range	$V_{COM_}$, $V_{NO_}$, $V_{NC_}$	(Note 4)	C, E	0		V_+	V
$COM_ -NO_$, $COM_ -NC_$ On-Resistance	R_{ON}	$V_+ = 4.5V$, $V_{COM_} = 3.5V$, $I_{COM_} = 1mA$	+25°C C, E		90	200 225	Ω
$COM_ -NO_$, $COM_ -NC_$ On-Resistance Match Between Channels (Note 5)	ΔR_{ON}	$V_+ = 4.5V$, $V_{COM_} = 3.5V$, $I_{COM_} = 1mA$	+25°C C, E		2	8 10	Ω
$NO_$, $NC_$ Off-Leakage Current (Notes 7, 10)	$I_{NO_ (OFF)}$, $I_{NC_ (OFF)}$	$V_+ = 5.5V$, $V_{COM_} = 1V$, $4.5V$, $V_{N_} = +4.5V$, $1V$	+25°C C, E	-1	0.01	1 10	nA
$COM_$ Off-Leakage Current (Notes 7, 10)	$I_{COM_ (OFF)}$	$V_+ = 5.5V$, $V_{COM_} = 1V$, $4.5V$, $V_{N_} = +4.5V$, $1V$	+25°C C, E	-1	0.01	1 10	nA
$COM_$ On-Leakage Current (Note 7, 10)	$I_{COM_ (ON)}$	$V_+ = 5.5V$, $V_{COM_} = 1V$, $4.5V$,	+25°C C, E	-2	0.01	2 20	nA
LOGIC INPUT							
\overline{EN} , $IN_$ Input Logic Threshold High	V_{INH}		C, E		1.4	2.4	V
\overline{EN} , $IN_$ Input Logic Threshold Low	V_{INL}		C, E	0.8	1.4		V
\overline{EN} , $IN_$ Input Current Logic High or Low	$I_{INH_}$, $I_{INL_}$	$V_{IN_} = 0.8V$ or $2.4V$	C, E	-1	0.03	1	μA
SWITCH DYNAMIC CHARACTERISTICS							
Turn-On Time	t_{ON}	$V_{COM_} = 3V$, $V_+ = 4.5V$ (Figure 1)	+25°C C, E		50	100 125	ns
Turn-Off Time	t_{OFF}	$V_{COM_} = 3V$, $V_+ = 4.5V$ (Figure 1)	+25°C C, E			80 100	ns
Break-Before-Make Time Delay	t_{BBM}	MAX4538, $V_{COM_} = 3V$, $V_+ = 5.5V$ (Figure 2)	+25°C		5	25	ns
Charge Injection (Figure 3) (Note 4)	Q	$C_L = 1.0nF$, $V_{NO} = 0V$, $R_S = 0\Omega$	+25°C		1	5	pC
POWER SUPPLY							
V_+ Supply Current	I_+	$V_+ = 5.5V$, all $V_{IN_} = 0V$ or V_+	+25°C C, E	-1	0.05	1 10	μA

Quad, Low-Voltage, SPST Analog Switches with Enable

MAX4536/MAX4537/MAX4538

ELECTRICAL CHARACTERISTICS—+3V Single Supply

($V_+ = 2.7V$ to $3.6V$, $V_- = 0V$, $V_{INH} = 2.0V$, $V_{INL} = 0.5V$, $V_{\overline{EN}} = 0.5V$, $T_A = T_{MIN}$ to T_{MAX} , unless otherwise noted. Typical values are at $T_A = +25^\circ C$.)

PARAMETER	SYMBOL	CONDITIONS	T_A	MIN	TYP (Note 3)	MAX	UNITS
ANALOG SWITCH							
Analog Signal Range	$V_{COM_}$, $V_{NO_}$, $V_{NC_}$	(Note 4)	C, E	0		V_+	V
COM_-NO_, COM_-NC_ On-Resistance	R_{ON}	$V_+ = 2.7V$, $V_{COM_} = 1.5V$, $I_{COM_} = 0.1mA$	+25°C		210	500	Ω
			C, E			600	
LOGIC INPUT							
\overline{EN} , IN_ Input Logic Threshold High	V_{INH}		C, E		0.9	2.0	V
\overline{EN} , IN_ Input Logic Threshold Low	V_{INL}		C, E	0.5	0.9		V
\overline{EN} , IN_ Input Current Logic High or Low	$I_{INH_}$, $I_{INL_}$	$V_{IN_} = 0.8V$ or $2.4V$	C, E	-1	0.03	1	μA
SWITCH DYNAMIC CHARACTERISTICS (Note 4)							
Turn-On Time	t_{ON}	$V_{COM_} = 1.5V$, $V_+ = 2.7V$ (Figure 1)	+25°C		80	250	ns
			C, E			300	
Turn-Off Time	t_{OFF}	$V_{COM_} = 1.5V$, $V_+ = 2.7V$ (Figure 1)	+25°C		40	100	ns
			C, E			120	
Break-Before-Make Time Delay	t_{BBM}	MAX4538, $V_{COM_} = 1.5V$, $V_+ = 3.6V$ (Figure 2)	+25°C	10	40		ns
Charge Injection (Figure 3)	Q	$C_L = 1.0nF$, $V_{NO} = 0V$, $R_S = 0\Omega$	+25°C			3	pC
POWER SUPPLY							
V_+ Supply Current	I_+	$V_+ = 3.6V$, all $V_{IN_} = 0V$ or V_+	+25°C	-1	0.05	1	μA
			C, E	-10		10	

Note 3: The algebraic convention is used in this data sheet; the most negative value is shown in the minimum column.

Note 4: Guaranteed by design.

Note 5: $\Delta R_{ON} = \Delta R_{ON(MAX)} - \Delta R_{ON(MIN)}$.

Note 6: Resistance flatness is defined as the difference between the maximum and the minimum value of on-resistance as measured over the specified analog-signal range.

Note 7: Leakage parameters are 100% tested at maximum rated hot temperature and guaranteed by correlation at $T_A = +25^\circ C$.

Note 8: Off-isolation = $20\log_{10} [V_{COM_} / (V_{NC_} \text{ or } V_{NO_})]$, $V_{COM_}$ = output, $V_{NC_}$ or $V_{NO_}$ = input to off switch.

Note 9: Between any two switches.

Note 10: Leakage testing for single-supply operation is guaranteed by testing with dual supplies.

Quad, Low-Voltage, SPST Analog Switches with Enable

Typical Operating Characteristics

($V_+ = +5V$, $V_- = -5V$ GND = 0V, $T_A = +25^\circ C$, unless otherwise noted.)

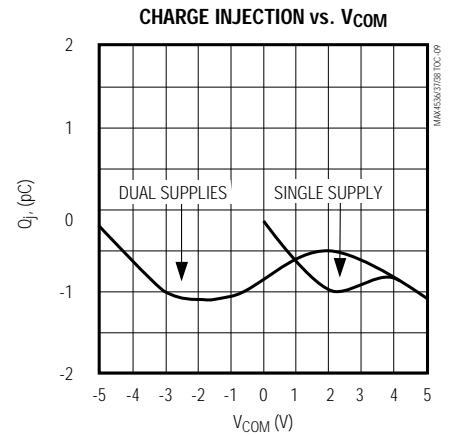
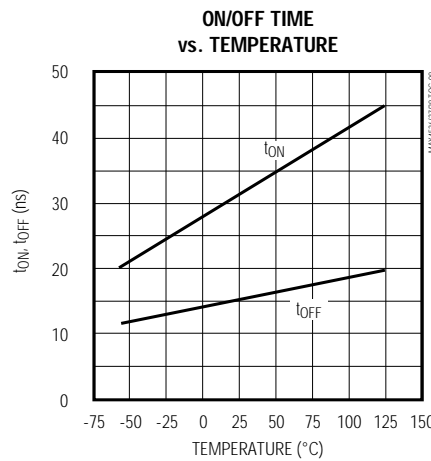
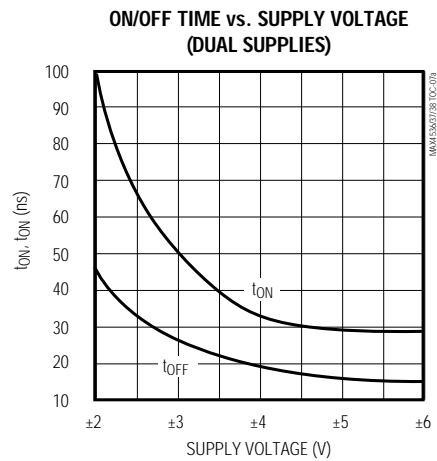
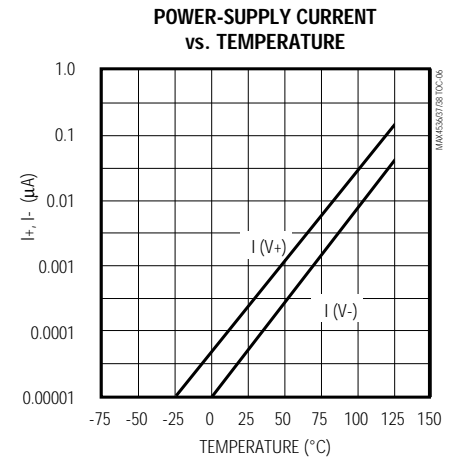
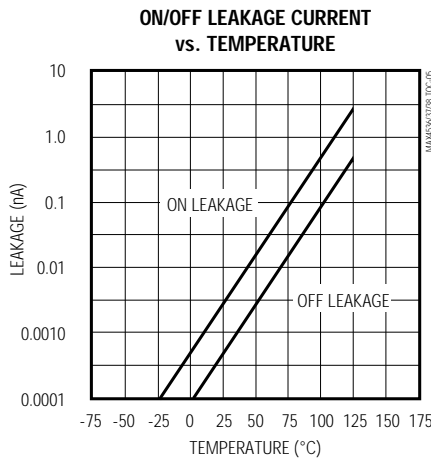
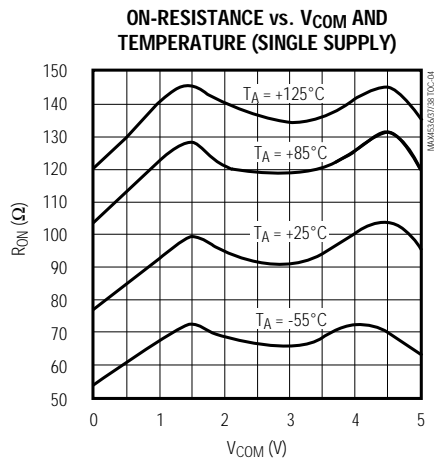
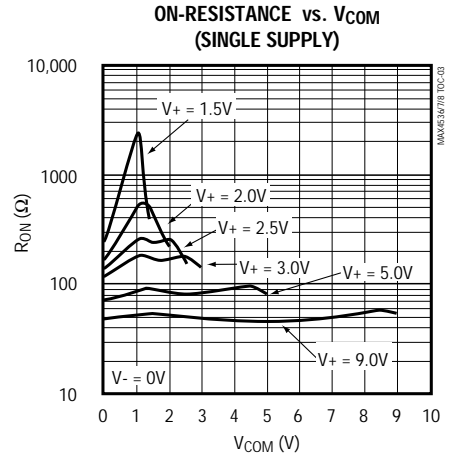
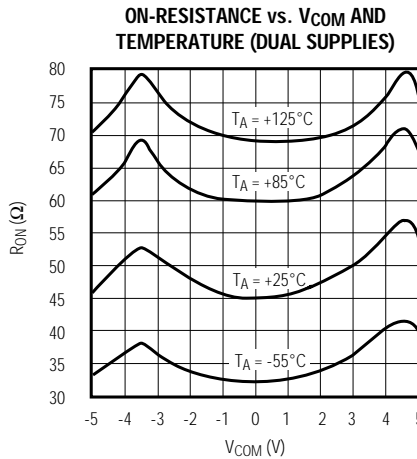
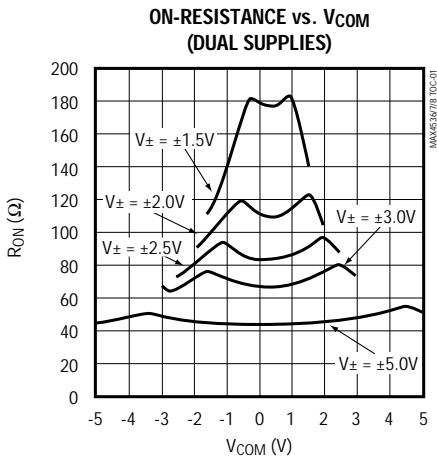

Quad, Low-Voltage, SPST Analog Switches with Enable

Typical Operating Characteristics (continued)

(V+ = +5V, V- = -5V GND = 0V, TA = +25°C, unless otherwise noted.)

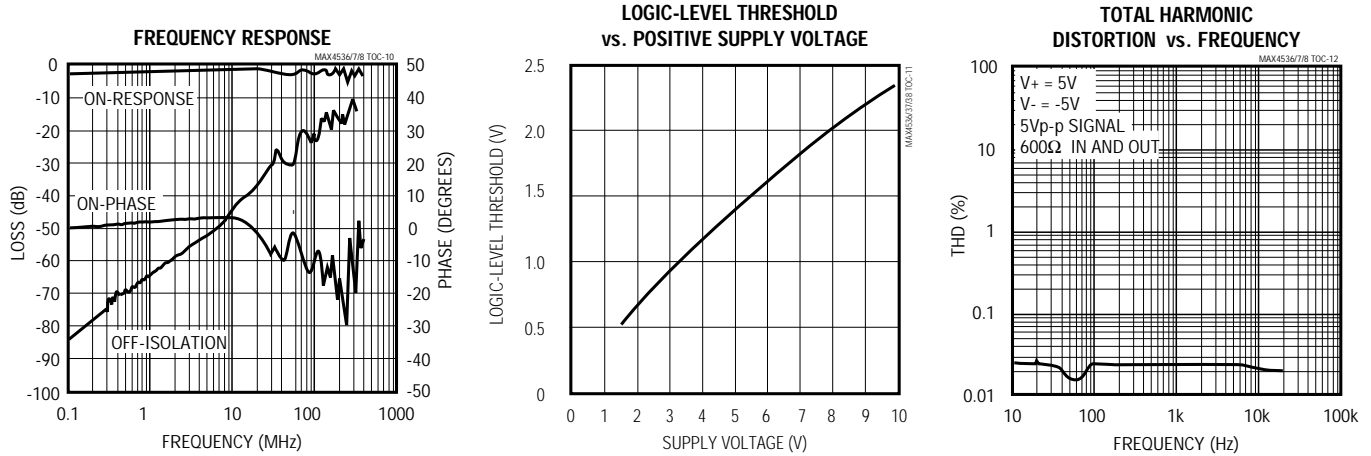

Pin Description

PIN	NAME	FUNCTION
1, 4, 10, 13	COM1-COM4	Analog Switch Common* Terminals
2, 3, 11, 12	NO1-NO4, or NC1-NC4	Analog Switch Normally Open* or Normally Closed* Terminals (see <i>Truth Tables</i>)
5, 6, 14, 15	IN1-IN4	Logic-Control Digital Inputs. Control each switch (see <i>Truth Tables</i>), except when \overline{EN} is high.
7	\overline{EN}	Disable Logic Input. Connect logic high to \overline{EN} to disable (open) all switches.
8	GND	Ground. Connect to digital ground. (Analog signals have no ground reference; they are limited to V+ and V-.)
9	V-	Negative Analog Supply-Voltage Input. Connect V- to GND for single-supply operation.
16	V+	Positive Analog and Digital Supply-Voltage Input. Internally connected to substrate.

*NO_/NC_ and COM_ pins are identical and interchangeable. Either may be considered as an input or an output; signals pass equally well in either direction.

MAX4536/MAX4537/MAX4538

Quad, Low-Voltage, SPST Analog Switches with Enable

Applications Information

Power-Supply Considerations

Overview

The MAX4536/MAX4537/MAX4538 construction is typical of most CMOS analog switches. These devices have three supply pins: V+, V-, and GND. V+ and V- drive the internal CMOS switches and set the limits of the analog voltage on any switch. Reverse ESD-protection diodes are internally connected between each analog-signal pin, and both V+ and V-. One of these diodes conducts if any analog signal exceeds V+ or V-. These reverse-biased ESD diodes leak during normal operation, forming the only current drawn from V+ or V-.

Virtually all the analog leakage current is through the ESD diodes. Although the ESD diodes on a given signal pin are identical and therefore fairly well balanced, they are reverse biased differently. Each is biased by either V+ or V- and the analog signal. This means their leakages vary as the signal varies. The *difference* in the two diode leakages from the signal path to the V+ and V- pins constitutes the analog-signal path leakage current. All analog leakage current flows to the supply terminals, not to the other switch terminal. This explains how both sides of a given switch can show leakage currents of either the same or opposite polarity.

There is no connection between the analog-signal paths and GND. The analog-signal paths consist of an N-channel and P-channel MOSFET with their sources and drains paralleled and their gates driven out of phase to V+ and V- by the logic-level translators.

V+ and GND power the internal logic and logic-level translators and set the input logic thresholds. The logic-level translators convert the logic levels to switched V+ and V- signals to drive the analog switches' gates. This drive signal is the only connection between the logic supplies and the analog supplies. V+, and V- have ESD-protection diodes to GND. The logic-level inputs have ESD protection to V+ and to V-.

Increasing V- has no effect on the logic-level thresholds, but it does increase the drive to the P-channel switches, reducing their on-resistance. V- also sets the negative limit of the analog-signal voltage.

The logic-level thresholds are CMOS/TTL-compatible when V+ is +5V. The threshold increases slightly as V+ is raised. When V+ reaches +12V, the level threshold is about 3.1V, above the TTL output high-level minimum of 2.8V, but still compatible with CMOS outputs.

Bipolar Supplies

The MAX4536/MAX4537/MAX4538 operate with bipolar supplies between $\pm 2.0\text{V}$ and $\pm 6\text{V}$. The V+ and V- supplies need not be symmetrical, but their sum cannot exceed the absolute maximum rating of 13.0V. **Do not connect the MAX4536/MAX4537/MAX4538's V+ to +3V and then connect the logic-level input pins to TTL logic-level signals. TTL logic-level outputs in excess of the absolute maximum ratings can damage the part and/or external circuits.**

CAUTION: The absolute maximum V+ to V- differential voltage is 13.0V. Typical $\pm 6\text{V}$ or +12V supplies with $\pm 10\%$ tolerances can be as high as 13.2V. This voltage can damage the MAX4536/MAX4537/MAX4538. Even $\pm 5\%$ tolerance supplies may have overshoot or noise spikes that exceed 13.0V.

Single Supplies

The MAX4536/MAX4537/MAX4538 operate from single supplies between +2.0V and +12V when V- is connected to GND. All of the bipolar precautions must be observed.

High-Frequency Performance

In 50Ω systems, signal response is reasonably flat up to 50MHz (see *Typical Operating Characteristics*). Above 20MHz, the on-response has several minor peaks that are highly layout dependent. The problem with high-frequency operation is not in turning the switch on, but in turning it off. The off-state switch acts like a capacitor and passes higher frequencies with less attenuation. At 10MHz, off-isolation is about -44dB in 50Ω systems, becoming worse (approximately 20dB per decade) as frequency increases. Higher circuit impedances also make off-isolation worse. Adjacent channel attenuation is about 3dB above that of a bare IC socket, and is due entirely to capacitive coupling.

Quad, Low-Voltage, SPST Analog Switches with Enable

Test Circuits/Timing Diagrams

MAX4536/MAX4537/MAX4538

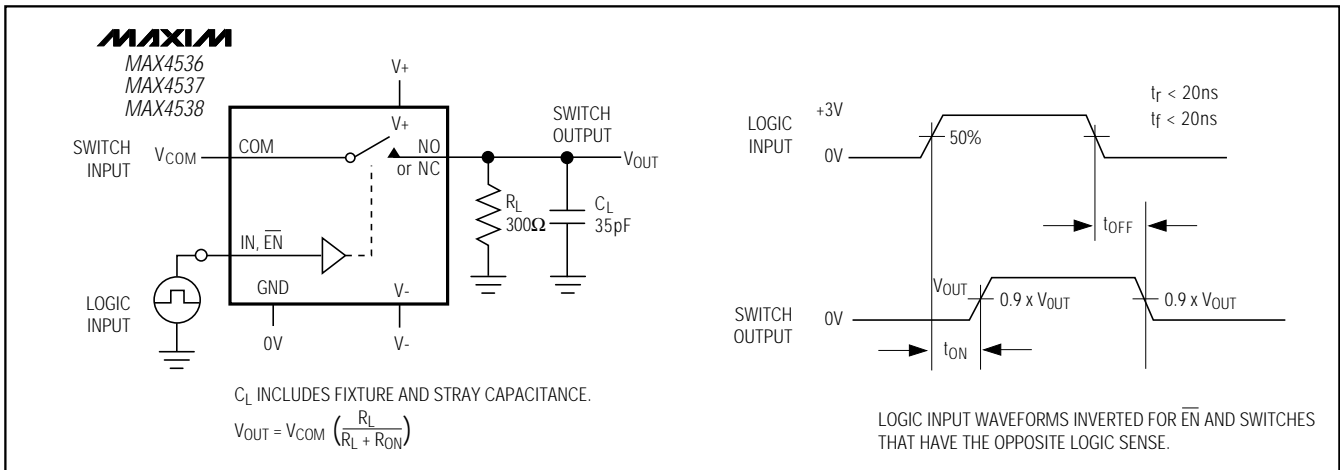

Figure 1. Switching Time

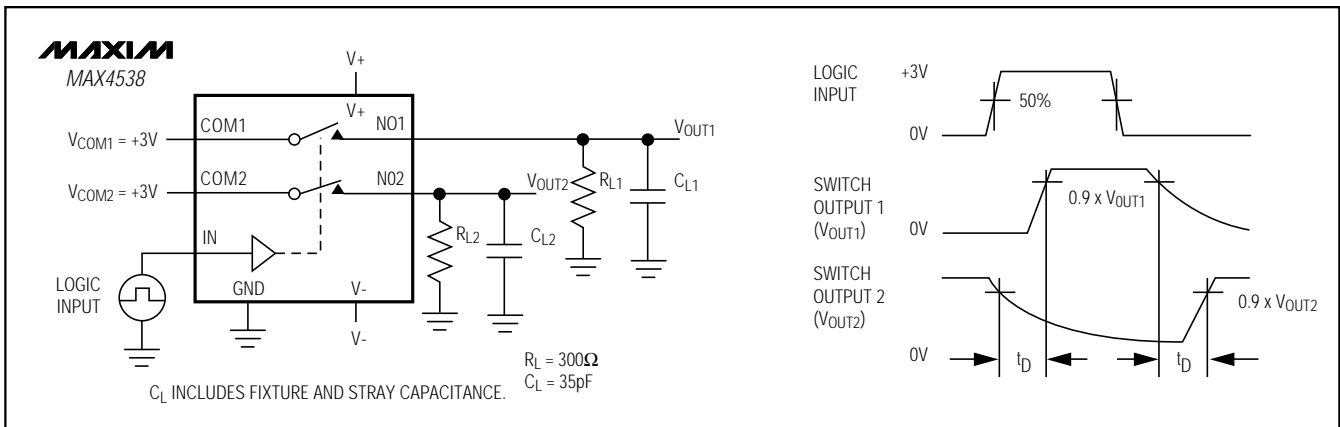

Figure 2. Break-Before-Make Interval (MAX4538 only)

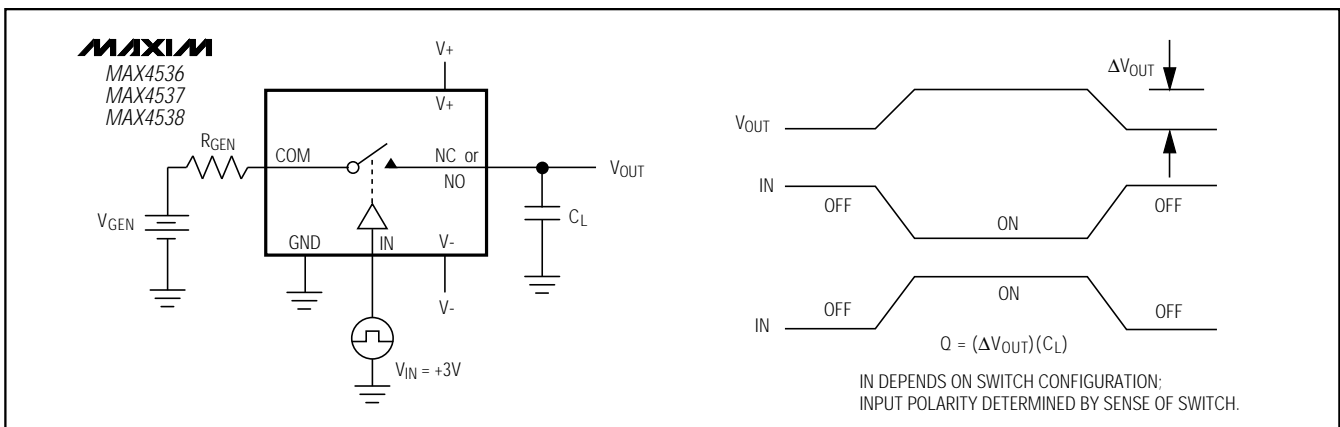

Figure 3. Charge Injection

Quad, Low-Voltage, SPST Analog Switches with Enable

MAX4536/MAX4537/MAX4538

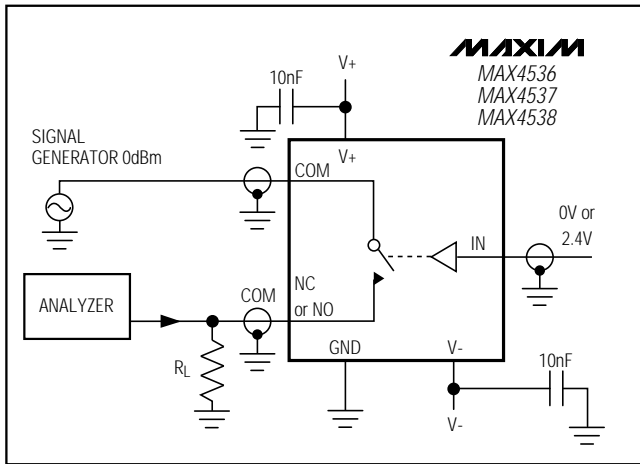

Figure 4. Off Isolation

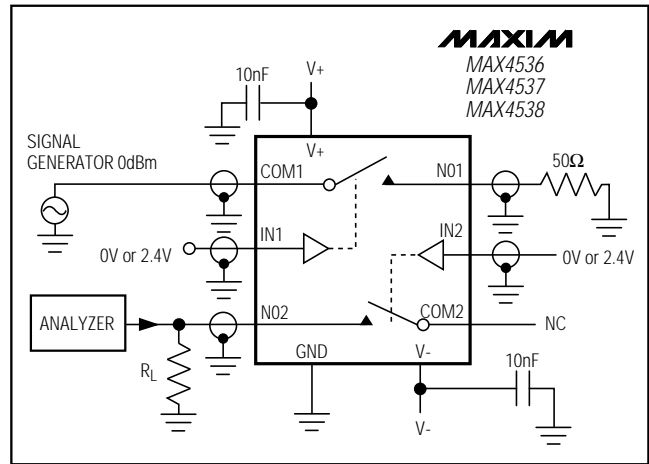

Figure 5. Crosstalk

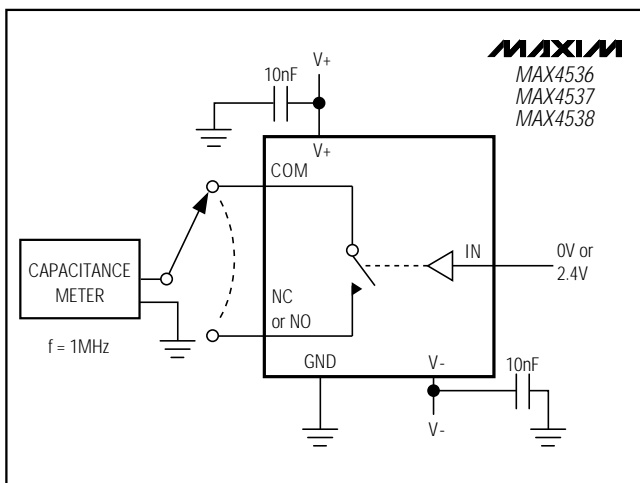

Figure 6. Channel-Off Capacitance

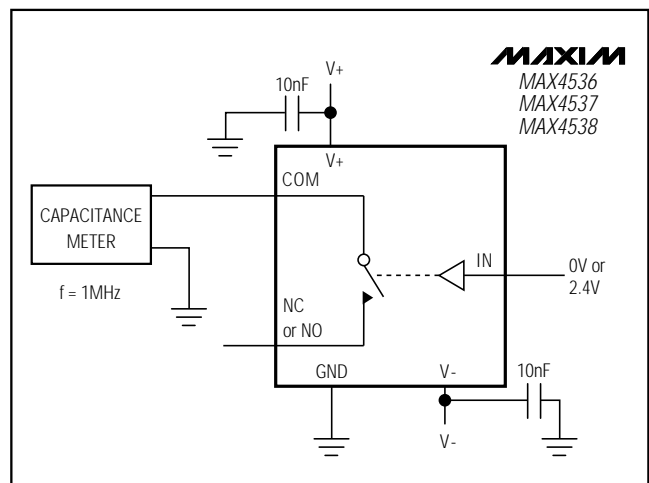

Figure 7. Channel-On Capacitance

Quad, Low-Voltage, SPST Analog Switches with Enable

Ordering Information (continued)

PART	TEMP. RANGE	PIN-PACKAGE
MAX4537 CPE	0°C to +70°C	16 Plastic DIP
MAX4537CSE	0°C to +70°C	16 Narrow SO
MAX4537CEE	0°C to +70°C	16 QSOP
MAX4537C/D	0°C to +70°C	Dice*
MAX4537EPE	-40°C to +85°C	16 Plastic DIP
MAX4537ESE	-40°C to +85°C	16 Narrow SO
MAX4537EEE	-40°C to +85°C	16 QSOP
MAX4538 CPE	0°C to +70°C	16 Plastic DIP
MAX4538CSE	0°C to +70°C	16 Narrow SO
MAX4538CEE	0°C to +70°C	16 QSOP
MAX4538C/D	0°C to +70°C	Dice*
MAX4538EPE	-40°C to +85°C	16 Plastic DIP
MAX4538ESE	-40°C to +85°C	16 Narrow SO
MAX4538EEE	-40°C to +85°C	16 QSOP

*Contact factory for availability.

Chip Topography

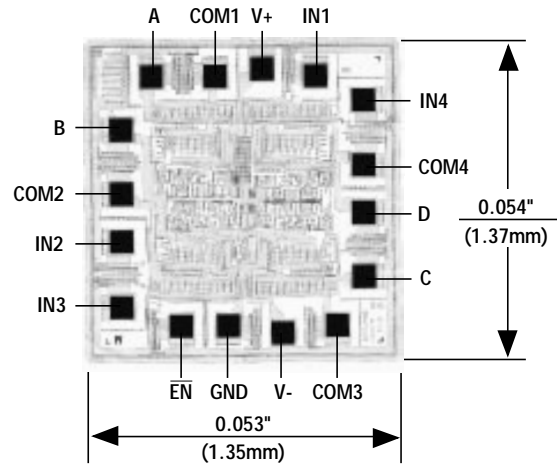

MAX4536		MAX4537		MAX4538	
PIN	NAME	PIN	NAME	PIN	NAME
A	NO1	A	NC1	A	NO1
B	NO2	B	NC2	B	NC2
C	NO3	C	NC3	C	NC3
D	NO4	D	NC4	D	NO4

TRANSISTOR COUNT: 121

SUBSTRATE IS INTERNALLY CONNECTED TO V+

MAX4536/MAX4537/MAX4538

Quad, Low-Voltage, SPST Analog Switches with Enable

Package Information

DIM	INCHES		MILLIMETERS	
	MIN	MAX	MIN	MAX
A	0.061	0.068	1.55	1.73
A1	0.004	0.0098	0.127	0.25
A2	0.055	0.061	1.40	1.55
B	0.008	0.012	0.20	0.31
C	0.0075	0.0098	0.19	0.25
D	SEE VARIATIONS			
E	0.150	0.157	3.81	3.99
e	0.025 BSC		0.635 BSC	
H	0.230	0.244	5.84	6.20
h	0.010	0.016	0.25	0.41
L	0.016	0.035	0.41	0.89
N	SEE VARIATIONS			
S	SEE VARIATIONS			
α	0°	8°	0°	8°

DIM	PINS	INCHES		MILLIMETERS	
		MIN	MAX	MIN	MAX
D	16	0.189	0.196	4.80	4.98
S	16	0.0020	0.0070	0.05	0.18
D	20	0.337	0.344	8.56	8.74
S	20	0.0500	0.0550	1.27	1.40
D	24	0.337	0.344	8.56	8.74
S	24	0.0250	0.0300	0.64	0.76
D	28	0.386	0.393	9.80	9.98
S	28	0.0250	0.0300	0.64	0.76

21-0055A

**QSOP
QUARTER
SMALL-OUTLINE
PACKAGE**

DIM	INCHES		MILLIMETERS	
	MIN	MAX	MIN	MAX
A	0.053	0.069	1.35	1.75
A1	0.004	0.010	0.10	0.25
B	0.014	0.019	0.35	0.49
C	0.007	0.010	0.19	0.25
E	0.150	0.157	3.80	4.00
e	0.050		1.27	
H	0.228	0.244	5.80	6.20
L	0.016	0.050	0.40	1.27

**Narrow SO
SMALL-OUTLINE
PACKAGE
(0.150 in.)**

DIM	PINS	INCHES		MILLIMETERS	
		MIN	MAX	MIN	MAX
D	8	0.189	0.197	4.80	5.00
D	14	0.337	0.344	8.55	8.75
D	16	0.386	0.394	9.80	10.00

21-0041A

Maxim cannot assume responsibility for use of any circuitry other than circuitry entirely embodied in a Maxim product. No circuit patent licenses are implied. Maxim reserves the right to change the circuitry and specifications without notice at any time.

12 _____ Maxim Integrated Products, 120 San Gabriel Drive, Sunnyvale, CA 94086 (408) 737-7600