

Absolute Maximum Ratings

V _{CC_} to GND_.....	-0.3V to +3.9V	Junction Temperature.....	+150°C
V _{CP} to GND_.....	-0.3V to +5.8V	Operating Temperature Range.....	-40°C to +85°C
CP to GND_.....	-0.3V to (V _{CP} + 0.3V)	Storage Temperature Range.....	-65°C to +150°C
All Other Pins to GND_.....	-0.3V to (V _{CC_} + 0.3V)	Lead Temperature (soldering, 10s).....	+300°C
RFINP, RFINN.....	+10dBm	Soldering Temperature (reflow).....	+260°C
Continuous Power Dissipation (T _A = +70°C)			
TQFN (derate 25.6mW/°C above +70°C).....	2051.3mW		

Package Thermal Characteristics (Note 1)

TQFN		TSSOP	
Junction-to-Ambient Thermal Resistance (θ _{JA}).....	39°C/W	Junction-to-Ambient Thermal Resistance (θ _{JA}).....	90°C/W
Junction-to-Case Thermal Resistance (θ _{JC}).....	6°C/W	Junction-to-Case Thermal Resistance (θ _{JC}).....	27°C/W

Note 1: Package thermal resistances were obtained using the method described in JEDEC specification JESD51-7, using a four-layer board. For detailed information on package thermal considerations, refer to www.maximintegrated.com/thermal-tutorial.

DC Electrical Characteristics

(Measured using the MAX2880 Evaluation Kit. V_{CC_} = 3V to 3.6V, V_{CP} = V_{CC_} to 5.5V, V_{GND_} = 0V, f_{REF} = 50MHz, f_{PFD} = 50MHz, T_A = -40°C to +85°C. Typical values measured at V_{CC_} = 3.3V, V_{CP} = 5V, T_A = +25°C, no RF applied, Registers 0 through 4 settings: 303C0000, 00000009, 00008052, 00000BC3, 00000084, unless otherwise noted.) (Note 2)

PARAMETER	CONDITIONS	MIN	TYP	MAX	UNITS
Supply Voltage (V _{CC_})		2.8	3.3	3.6	V
Charge-Pump Supply (V _{CP})		V _{CC_}		5.5	V
V _{CC_} Supply Current	PRE = 0, RFINN = 6GHz		39	50	mA
	PRE = 1, RFINN = 12GHz		49	59	
	Shutdown Mode			1	
V _{CP} Supply Current			0.65	2.0	mA

AC Electrical Characteristics

(Measured using the MAX2880 Evaluation Kit. V_{CC_} = 3V to 3.6V, V_{CP} = V_{CC_} to 5.5V, V_{GND_} = 0V, f_{REF} = 50MHz, f_{PFD} = 50MHz, f_{RFINN} = 6000MHz, T_A = -40°C to +85°C. Typical values measured at V_{CC_} = 3.3V, V_{CP} = 5V, T_A = +25°C, P_{RFINN} = 2dBm, Registers 0 through 4 settings: 303C0000, 00000009, 00008052, 00000BC3, 00000084, unless otherwise noted.) (Note 2)

PARAMETER	CONDITIONS	MIN	TYP	MAX	UNITS
Input Frequency		250		12,400	MHz
Input Power		-10		+5	dBm
REF Input Frequency Range		10		210	MHz
REF Input Sensitivity		0.7		V _{CC_}	V _{P-P}
REF Input Capacitance			2		pF
REF Input Current		-60		+60	µA
Phase Detector Frequency	Fractional mode			125	MHz
	Integer mode			140	
Sink/Source Current	CP[3:0] = 1111, R _{RSET} = 5.1kΩ		5.12		mA
	CP[3:0] = 0000, R _{RSET} = 5.1kΩ		0.32		

AC Electrical Characteristics (continued)

(Measured using the MAX2880 Evaluation Kit. $V_{CC_} = 3V$ to $3.6V$, $V_{CP} = V_{CC_}$ to $5.5V$, $V_{GND_} = 0V$, $f_{REF} = 50MHz$, $f_{PFD} = 50MHz$, $f_{RFINN} = 6000MHz$, $T_A = -40^{\circ}C$ to $+85^{\circ}C$. Typical values measured at $V_{CC_} = 3.3V$, $V_{CP} = 5V$, $T_A = +25^{\circ}C$, $P_{RFINN} = 2dBm$, Registers 0 through 4 settings: 303C0000, 00000009, 00008052, 00000BC3, 00000084, unless otherwise noted.) (Note 2)

PARAMETER	CONDITIONS	MIN	TYP	MAX	UNITS
RSET Range		2.7		10	k Ω
Charge-Pump Output Voltage		0.5	$V_{CP} - 0.5$		V
In-Band Noise Floor	Normalized (Note 3)		-229		dBc/Hz
1/f Noise	Normalized (Note 4)		-122		dBc/Hz
In-Band Phase Noise	(Note 5)		-101		dBc/Hz
Integrated RMS Jitter	(Note 6)		0.14		ps
Spurious Signals Due to PFD			-84		dBc
ADC Resolution			7		Bits
Temperature Sensor Accuracy	$T_A = -40^{\circ}C$ to $+85^{\circ}C$		± 2.0		$^{\circ}C$

Digital I/O Characteristics

($V_{CC_} = 3V$ to $3.6V$, $V_{GND_} = 0V$, $T_A = -40^{\circ}C$ to $+85^{\circ}C$. Typical values at $V_{CC_} = 3.3V$, $T_A = +25^{\circ}C$.) (Note 2)

PARAMETER	SYMBOL	CONDITIONS	MIN	TYP	MAX	UNITS
Input Logic-Level Low	V_{IL}			0.4		V
Input Logic-Level High	V_{IH}			1.5		V
Input Current	I_{IH}/I_{IL}		-1		+1	μA
Input Capacitance				1		pF
Output Logic-Level Low	V_{OL}	0.3mA sink current			0.4	V
Output Logic-Level High	V_{OH}	0.3mA source current	$V_{CC_} - 0.4$			V
Output Current Level High	I_{OH}			0.5		mA

SPI Timing Characteristics

(V_{CC_} = 3V to 3.6V, V_{GND_} = 0V, T_A = -40°C to +85°C. Typical values at V_{CC_} = 3.3V, T_A = +25°C.) (Note 2)

PARAMETER	SYMBOL	CONDITIONS	MIN	TYP	MAX	UNITS
CLK Clock Period	t _{CP}	Guaranteed by SCL pulse-width low and high		50		ns
CLK Pulse-Width Low	t _{CL}			25		ns
CLK Pulse-Width High	t _{CH}			25		ns
LE Setup Time	t _{LES}			20		ns
LE Hold Time	t _{LEH}			10		ns
LE Minimum Pulse-Width High	t _{LEW}			20		ns
Data Setup Time	t _{DS}			25		ns
Data Hold Time	t _{DH}			25		ns
MUX Setup Time	t _{MS}			10		ns
MUX Hold Time	t _{MH}			10		ns

Note 2: Production tested at T_A = +25°C. Cold and hot are guaranteed by design and characterization.

Note 3: Measured at 100kHz offset with 50MHz Bliley NV108C1954 OCVCXO with 500kHz loop bandwidth. Registers 0 through 4 settings: 303C0000, 00000009, 0F008052, 000025C3, 00000094.

Note 4: 1/f noise contribution to the in-band noise is computed by using $1/f_{NOISE} = PN - 10\log(10\text{kHz}/f_{OFFSET}) - 20\log(f_{RF}/1\text{GHz})$. Registers 0 through 4 settings: 303C0000, 00000009, 0F008052, 000025C3, 00000094.

Note 5: f_{REF} = 50MHz; f_{PFD} = 50MHz; offset frequency = 10kHz; VCO frequency = 6GHz, N = 120; loop BW = 100kHz, CP[3:0] = 1111; integer mode. Registers 0 through 4 settings 303C0000, 00000009, 0F008052, 000025C3, 00000094.

Note 6: f_{REF} = 50MHz; f_{PFD} = 50MHz; VCO frequency = 6GHz; N = 120; loop BW = 100kHz, CP[3:0] = 1111; integer mode. Registers 0 through 4 settings 303C0000, 00000009, 0F008052, 000025C3, 00000094.

Typical Operating Characteristics

(Measured using the MAX2880 Evaluation Kit. V_{CC_} = 3.3V, V_{GND_} = 0V, V_{CP} = 5.0V, CP[3:0] = 1111, f_{RFINN} = 6GHz, f_{REF} = 50MHz, f_{PFD} = 50MHz, T_A = +25°C, unless otherwise noted. See Table 1 and Table 2).

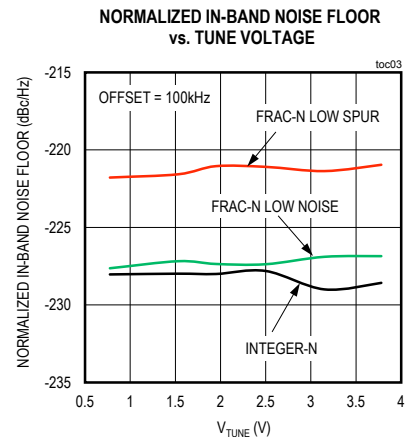
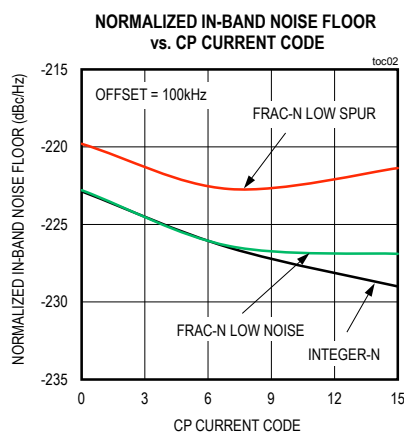
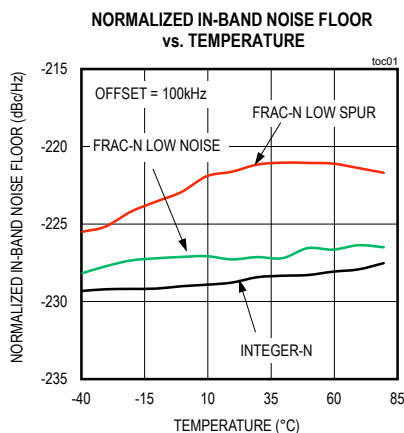

Typical Operating Characteristics (continued)

(Measured using the MAX2880 Evaluation Kit. $V_{CC-} = 3.3V$, $V_{GND-} = 0V$, $V_{CP} = 5.0V$, $CP[3:0] = 1111$, $f_{RFIN} = 6GHz$, $f_{REF} = 50MHz$, $f_{PFD} = 50MHz$, $T_A = +25^\circ C$, unless otherwise noted. See Table 1 and Table 2).

NORMALIZED 1/f NOISE vs. TEMPERATURE

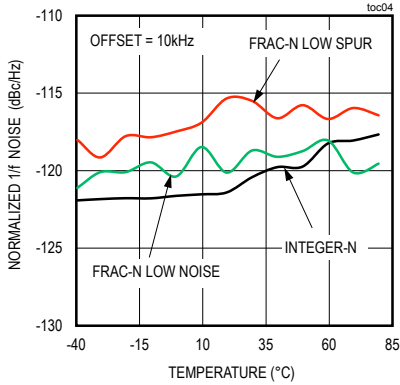

NORMALIZED 1/f NOISE vs. CP CURRENT CODE

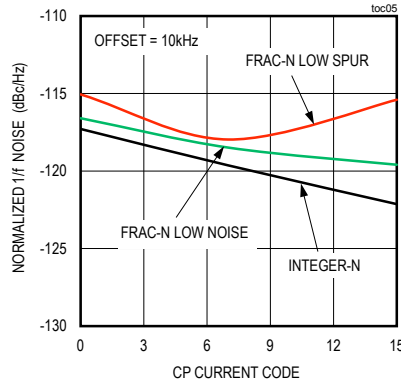

NORMALIZED 1/f NOISE vs. TUNE VOLTAGE

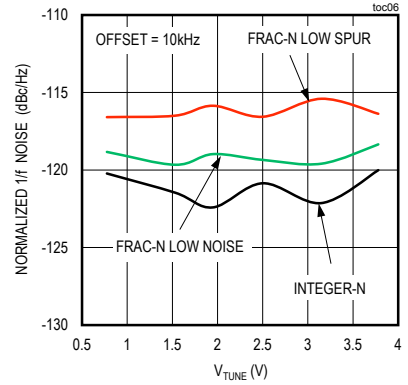

INTEGER-N CLOSED-LOOP PHASE NOISE vs. OFFSET FREQUENCY

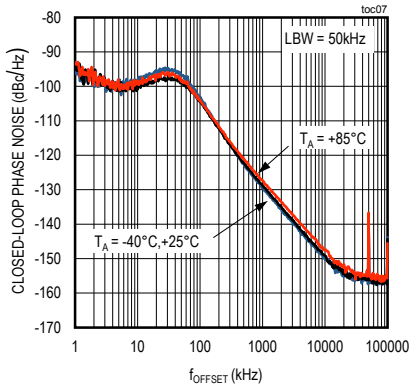

FRAC-N LOW-NOISE MODE CLOSED-LOOP PHASE NOISE vs. OFFSET FREQUENCY

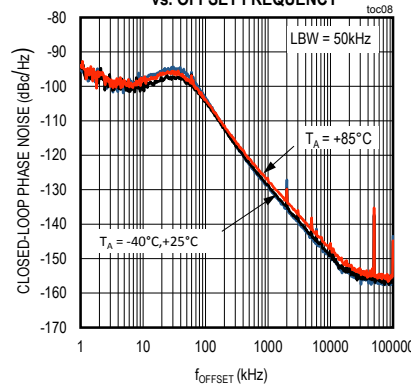

FRAC-N LOW-SPUR MODE CLOSED-LOOP PHASE NOISE vs. OFFSET FREQUENCY

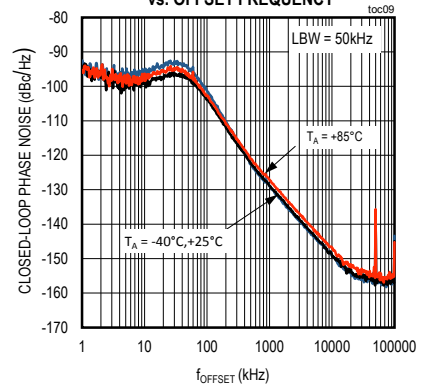

RF INPUT SENSITIVITY vs. FREQUENCY

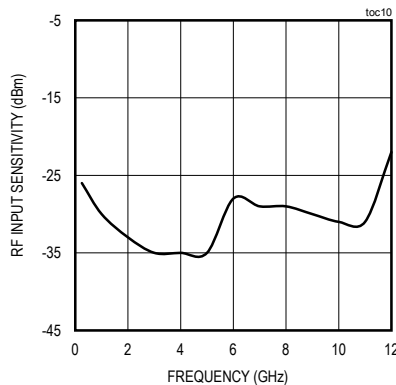

Table 1. Typical Operating Characteristics Testing Conditions

TOC	MODE	REG 0 (hex)	REG 1 (hex)	REG 2 (hex)	REG 3 (hex)	REG 4 (hex)	COMMENTS
1	INTEGER N	303C0000	04000001	2F00FFFA	00000543	00000004	LBW = 500kHz
	FRAC N LOW SPUR	303C00A0	04000001	6F008C82	00000B43	00000004	
	FRAC N LOW NOISE	303C00A0	04000001	0F008C82	00000343	00000004	
2	INTEGER N	303C0000	04000001	2F00FFFA	00000543	00000004	LBW = 500kHz
	FRAC N LOW SPUR	303C00A0	04000001	6F008C82	00000B43	00000004	
	FRAC N LOW NOISE	303C00A0	04000001	0F008C82	00000343	00000004	
3	INTEGER N	303C0000	04000001	2F00FFFA	00000543	00000004	LBW = 500kHz
	FRAC N LOW SPUR	303C00A0	04000001	6F008C82	00000B43	00000004	
	FRAC N LOW NOISE	303C00A0	04000001	0F008C82	00000343	00000004	
4	INTEGER N	303C0000	04000001	2F00FFFA	00000543	00000004	LBW = 500kHz
	FRAC N LOW SPUR	303C00A0	04000001	6F008C82	00000B43	00000004	
	FRAC N LOW NOISE	303C00A0	04000001	0F008C82	00000343	00000004	
5	INTEGER N	303C0000	04000001	2F00FFFA	00000543	00000004	LBW = 500kHz
	FRAC N LOW SPUR	303C00A0	04000001	6F008C82	00000B43	00000004	
	FRAC N LOW NOISE	303C00A0	04000001	0F008C82	00000343	00000004	
6	INTEGER N	303C0000	04000001	2F00FFFA	00000543	00000004	LBW = 500kHz
	FRAC N LOW SPUR	303C00A0	04000001	6F008C82	00000B43	00000004	
	FRAC N LOW NOISE	303C00A0	04000001	0F008C82	00000343	00000004	
7	INTEGER N	303C0000	04000001	2F00FFFA	00000543	00000004	LBW = 50kHz
8	FRAC N LOW NOISE	303C00A0	04000001	0F008C82	00000343	00000004	LBW = 50kHz
9	FRAC N LOW SPUR	303C00A0	04000001	6F008C82	00000B43	00000004	LBW = 50kHz
10	INTEGER N	303C0000	04000001	2F00FFFA	00000543	00000004	$f_{RF} < 6.2\text{GHz}$
	INTEGER N	303C0000	06000001	2F00FFFA	00000543	00000004	$f_{RF} \geq 6.2\text{GHz}$

Table 2. Loop Filter Component

LOOP BW (kHz)	K_{VCO} (MHz/V)	CP CODE	f_{REF} (MHz)	f_{PFD} (MHz)	MAX2880 EVALUATION KIT COMPONENT VALUES				
					C14	C13	R10	R33	C15
50	85	1111	50	50	10nF	100nF	100 Ω	47.5 Ω	1000pF
100	85	1111	50	50	680pF	0.1 μ F	174 Ω	100 Ω	18pF
500	85	0001	50	50	Open	330pF	15k Ω	0 Ω	Open
500	85	0111	50	50	12pF	2200pF	1820 Ω	100 Ω	18pF
500	85	1111	50	50	33pF	4700pF	910 Ω	100 Ω	18pF

Pin Configuration

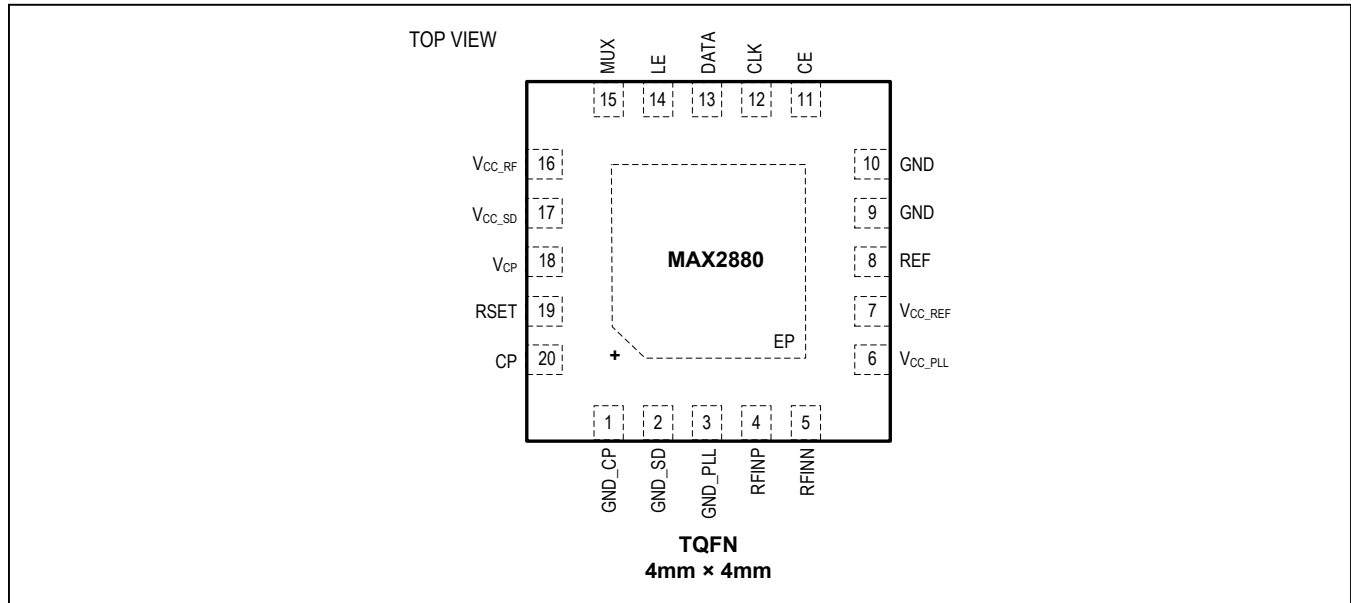

Pin Description

PIN	NAME	FUNCTION
1	GND_CP	Charge-Pump Ground. Connect to board ground, not to the paddle.
2	GND_SD	Sigma Delta Modulator Ground. Connect to board ground, not to the paddle.
3	GND_PLL	PLL Ground. Connect to board ground, not to the paddle.
4	RFINP	Positive RF Input to Prescaler. AC ground through capacitor, if not used.
5	RFINN	Negative RF Input to Prescaler. Connect to VCO output through coupling capacitor.
6	VCC_PLL	PLL Power Supply. Place decoupling capacitors as close as possible to pin.
7	VCC_REF	REF Power Supply. Place decoupling capacitors as close as possible to pin.
8	REF	Reference Frequency Input. This is a high-impedance input with a nominal bias voltage of $V_{CC_REF}/2$. AC-couple to reference signal.
9, 10	GND	Ground. Connect to the board ground, not the paddle.
11	CE	Chip Enable. A logic-low powers the device down.
12	CLK	Serial Clock Input. The data is latched into the 32-bit shift register on the rising edge of the CLK line.
13	DATA	Serial Data Input. The serial data is loaded MSB first. The 3 LSBs identify the register address.
14	LE	Load Enable Input. When LE goes high the data stored in the shift register is loaded into the appropriate register.
15	MUX	Multiplexed I/O. See Table 5.
16	VCC_RF	RF Power Supply. Place decoupling capacitors as close as possible to pin.
17	VCC_SD	Sigma Delta Modulator Power Supply. Place decoupling capacitors as close as possible to pin.
18	VCP	Charge-Pump Power Supply. Place decoupling capacitors as close as possible to the pin.
19	RSET	Charge-Pump Current Range Input. Connect an external resistor to ground to set the minimum CP current. $I_{CP} = 1.63/R_{SET} \times (1 + CP)$.
20	CP	Charge-Pump Output. Connect to external loop filter input.
—	EP	Exposed Pad. Connect to board ground.

Pin Configuration (continued)

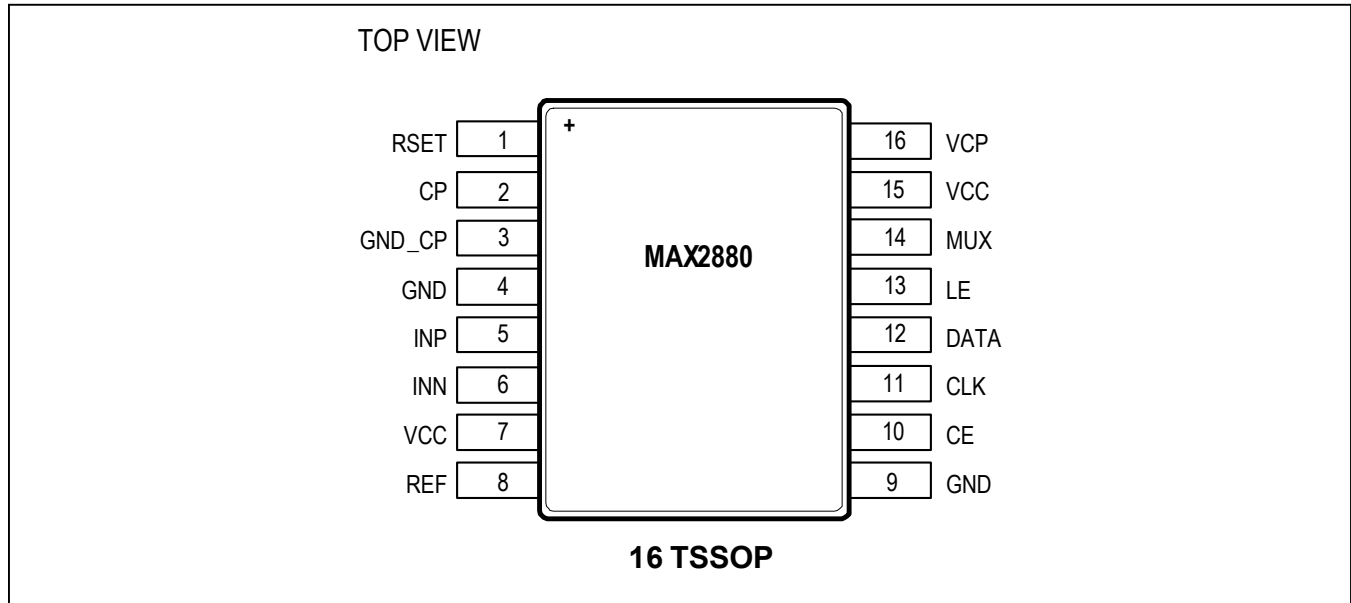

PIN	NAME	FUNCTION
1	RSET	Charge-Pump Current Range Input. Connect an external resistor to ground to set the minimum CP current. $I_{CP} = 1.63/R_{SET} \times (1 + CP)$.
2	CP	Charge-Pump Output. Connect to external loop filter input.
3	GND_CP	Charge-Pump Ground. Connect to board ground.
4	GND	Ground. Connect to board ground.
5	RFINP	Positive RF Input to Prescaler. AC ground through capacitor, if not used.
6	RFINN	Negative RF Input to Prescaler. Connect to VCO output through coupling capacitor.
7	VCC	Power Supply. Place decoupling capacitors as close as possible to pin.
8	REF	Reference Frequency Input. This is a high-impedance input with a nominal bias voltage of $V_{CC_REF}/2$. AC-couple to reference signal.
9	GND	Ground. Connect to the board ground.
10	CE	Chip Enable. A logic-low powers the device down.
11	CLK	Serial Clock Input. The data is latched into the 32-bit shift register on the rising edge of the CLK line.
12	DATA	Serial Data Input. The serial data is loaded MSB first. The 3 LSBs identify the register address.
13	LE	Load Enable Input. When LE goes high the data stored in the shift register is loaded into the appropriate register.
14	MUX	Multiplexed I/O. See Table 5.
15	VCC	Power Supply. Place decoupling capacitors as close as possible to pin.
16	VCP	Charge-Pump Power Supply. Place decoupling capacitors as close as possible to the pin.

Detailed Description

4-Wire Serial Interface

The MAX2880 serial interface contains five read-write and one read-only 32-bit registers. The 29 most-significant bits (MSBs) are data, and the three least-significant bits (LSBs) are the register address. Register data is loaded MSB first through the 4-wire serial port interface (SPI). When latch enable (LE) is logic-low, the logic level at DATA is shifted at the rising edge of CLK. At the rising edge of LE, the 29 data bits are latched into the register selected by the address bits. Default values are not guaranteed upon power-up. Program all register values after power-up.

Register programming order should be address 0x04, 0x03, 0x02, 0x01, and 0x00. Several bits are double buffered to update the settings at the same time. See the register descriptions for double buffered settings.

Any register can be read back through the MUX pin. The user must first set MUX bits = 0111. Next, write the register to be read, but with the READ bit of that register (the MSB) = 1. If the READ bit is set, the data of bits 30:3 do not matter because they are not latched into the register on a read operation. After the address bits are clocked and the LE pin is set, the MSB of that register appears on the MUX pin after the next rising edge on CLK pin. The MUX pin will continue to change after the rising edge of the next 28 clocks. After the LSB has been read, the user can reset the MUX bits to 0000.

Shutdown Mode

The MAX2880 can be put into shutdown mode by setting SHDN = 1 (register 3, bit 5) or by setting the CE pin to logic-low.

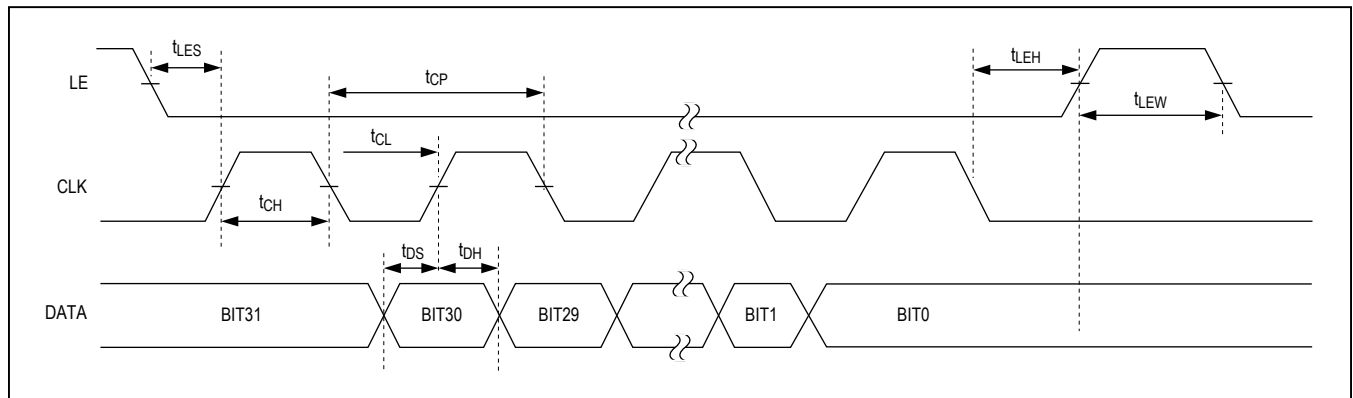

Figure 1. SPI Timing Diagram

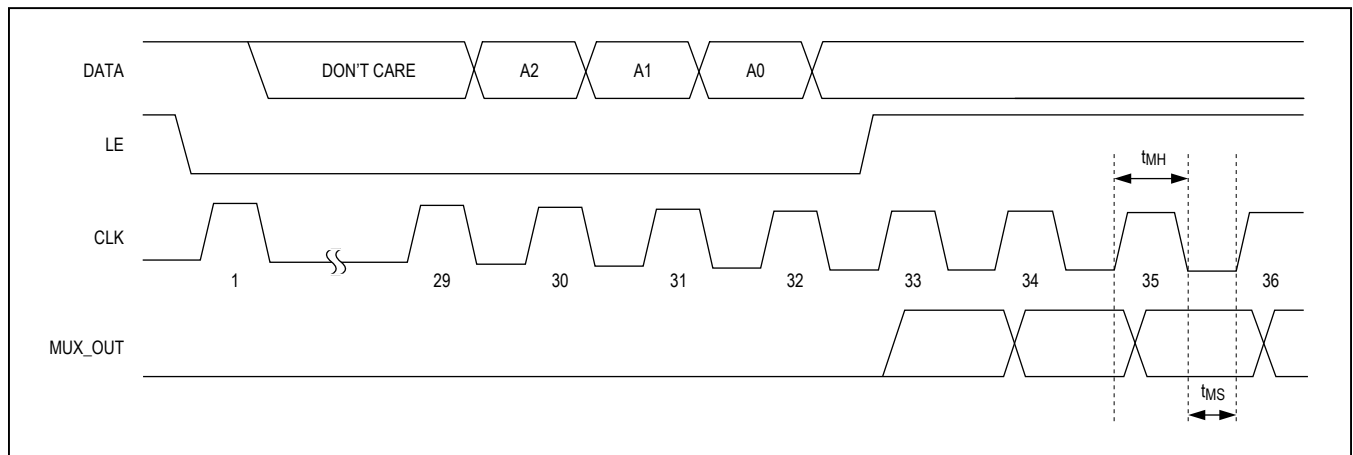

Figure 2. Initiating Readback

Reference Input

The reference input stage is configured as a CMOS inverter with shunt resistance from input to output. In shut-down mode this input is set to high impedance to prevent loading of the reference source.

The reference input signal path also includes optional x2 and ÷2 blocks. When the reference doubler is enabled (DBR = 1), the maximum reference input frequency is limited to 100MHz. When the doubler is disabled, the reference input frequency is limited to 205MHz. The minimum reference frequency is 10MHz. The minimum R counter divide ratio is 1, and the maximum divide ratio is 1023.

Int, Frac, Mod, and R Counter Relationship

The phase-detector frequency is determined as follows:

$$f_{\text{PFD}} = f_{\text{REF}} \times [(1 + \text{DBR}) / (\text{R} \times (1 + \text{RDIV2}))]$$

f_{REF} represents the external reference input frequency. DBR (register 2, bit 20) sets the f_{REF} input frequency doubler mode (0 or 1). RDIV2 (register 2, bit 21) sets the f_{REF} divide-by-2 mode (0 or 1). R (register 2, bits 19:15) is the value of the 5-bit programmable reference counter (1 to 31). The maximum f_{PFD} is 105MHz for Fractional-N and 140MHz for Integer-N. The R-divider can be held in reset when RST (register 3, bit 3) = 1.

The VCO frequency is determined as follows:

$$f_{\text{VCO}} = f_{\text{PFD}} \times (\text{N} + \text{F}/\text{M}) \times (\text{PRE} + 1)$$

N is the value of the 16-bit N counter (16 to 65535), programmable through bits 30:27 (MSBs) of register 1 and bits 26:15 of register 0 (LSBs). M is the fractional modulus value (2 to 4095), programmable through bits 14:3 of register 2. F is the fractional division value (0 to MOD - 1), programmable through bits 14:3 of register 0. In fractional-N mode, the minimum N value is 19 and maximum N value is 4091. The N counter is held in reset when RST = 1 (register 3, bit 3). PRE is RF input prescaler control where 0 = divide-by-1, and 1 = divide-by-2 (register 1, bit 25). If the RF input frequency is above 6.2GHz, then set PRE = 1.

Integer-N/Fractional-N Modes

Integer-N mode is selected by setting bit INT = 1 (register 3, bit 10). When operating in integer-N mode, it is also necessary to set bit Lock Detect Function, LDF = 1 (register 3, bit 9) to set the lock detect to integer-N mode.

The device's fractional-N mode is selected by setting bit INT = 0 (register 3, bit 10). Additionally, set bit LDF = 0 (register 3, bit 9) for fractional-N lock-detect mode.

If the device is in fractional-N mode, it will remain in fractional-N mode when fractional division value F = 0, which can result in unwanted spurs. To avoid this condition, the device can automatically switch to integer-N mode when F = 0 if the bit F01 = 1 (register 4, bit 29).

Phase Detector and Charge Pump

The device's charge-pump current is determined by the value of the resistor from pin RSET to ground and the value of bits CP (register 2, bits 27:24) as follows:

$$I_{\text{CP}} = 1.63/\text{R}_{\text{SET}} \times (1 + \text{CP})$$

When operating in the fractional-N mode, the charge-pump linearity (CPL) bits can be adjusted by the user to optimize in-band noise and spur levels. In the integer-N mode, CPL must be set to 0. If lower noise operation in integer-N mode is desired, set the charge-pump output clamp bit CPOC = 1 (register 3, bit 13) to prevent leakage current into the loop filter. In fractional-N mode, set CPOC = 0..

The charge-pump output can be put into high-impedance mode when TRI = 1 (register 3, bit 4). The output is in normal mode when TRI = 0.

The phase detector polarity can be changed if an active inverting loop filter topology is used. For noninverting loop filters, set PDP = 1 (register 3, bit 6). For inverting loop filters, set PDP = 0.

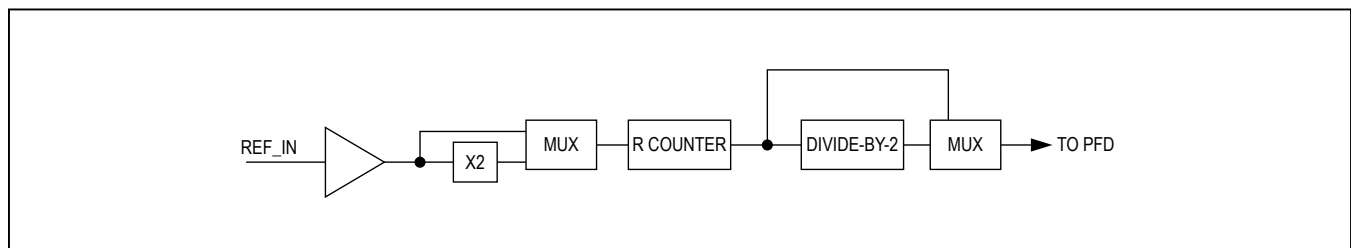

Figure 3. Reference Input

MUX and Lock Detect

MUX is a multipurpose test output for observing various internal functions of the MAX2880. MUX can also be configured as serial data output. MUX bits (register 0, bits 30:27) are used to select the desired MUX signal (see [Table 5](#)).

The digital lock detect is dependent on the mode of the synthesizer. In fractional-N mode set LDF = 0, and in integer-N mode set LDF = 1. To set the accuracy of the digital lock detect, see [Table 3](#) and [Table 4](#).

Cycle Slip Reduction

Cycle slip reduction is one of two available methods to improve lock time. It is enabled by setting CSR bit (register 2, bit 28) to 1. In this mode, the charge pump must be set for its minimum value.

Fast-Lock

Fast-lock is the other method available for improving lock time by temporarily increasing the loop bandwidth at the start of the locking cycle. It is enabled by setting the CDM bits to 01 (register 4, bits 20:19). In addition, the charge-pump current has to be set to CP = 0000 (register 2, bits 27:24), MUX bits configured to 1100 (register 0, bits 30:27), and the shunt resistive portion of the loop filter has to be segmented into two parts, where one resistor is 1/4 of the total resistance, and the other resistor is 3/4 of the total resistance. [Figure 4](#) and [Figure 5](#) illustrate the two

possible topologies. Once enabled, fast lock is activated after writing to register 0. During this process, the charge pump is automatically increased to its maximum (CP bits = 1111) and the shunt loop filter resistance is reduced to 1/4 of the total resistance when the internal switch shorts the MUX pin to ground. Bits CDIV (register 4, bits 18:7) control the time spent in the wide bandwidth mode. The time spent in the fast lock is:

$$t = \text{CDIV}/f_{\text{PFD}}$$

The time should be set long enough to allow the loop to settle before switching back to the lower loop bandwidth.

RF Inputs

The differential RF inputs are connected to a high-impedance input buffer which drives a demultiplexer for selecting between two RF input frequency ranges: 250MHz to 6.2GHz and 6.2GHz to 12.4GHz. When the RF input frequency is 250MHz to 6.2GHz, the fixed divide-by-2 prescaler is bypassed by setting bit PRE to 0. When the RF input frequency is 6.2GHz to 12.4GHz, the fixed divide-by-2 path is selected by setting PRE to 1. The supported input power range is -10dBm to +5dBm. For single-ended operation, terminate the unused RF input to GND through a 100pF capacitor.

Since the RF input of the device is high impedance, a DC isolated external shunt resistor is used to provide the 50Ω input impedance for the system (see the [Typical Application Circuit](#)).

Table 3. Fractional-N Digital Lock-Detect Settings

PFD FREQUENCY (MHz)	LDS	LDP	LOCKED UP/DOWN TIME SKEW (ns)	NUMBER OF LOCKED CYCLES TO SET LD	TIME SKEW TO UNSET LD (ns)
≤ 32	0	0	10	40	15
≤ 32	0	1	6	40	15
> 32	1	X	4	40	4

Table 4. Integer-N Digital Lock-Detect Settings

PFD FREQUENCY (MHz)	LDS	LDP	LOCKED UP/DOWN TIME SKEW (ns)	NUMBER OF LOCKED CYCLES TO SET LD	TIME SKEW TO UNSET LD (ns)
≤ 32	0	0	10	5	15
≤ 32	0	1	6	5	15
> 32	1	X	4	5	4

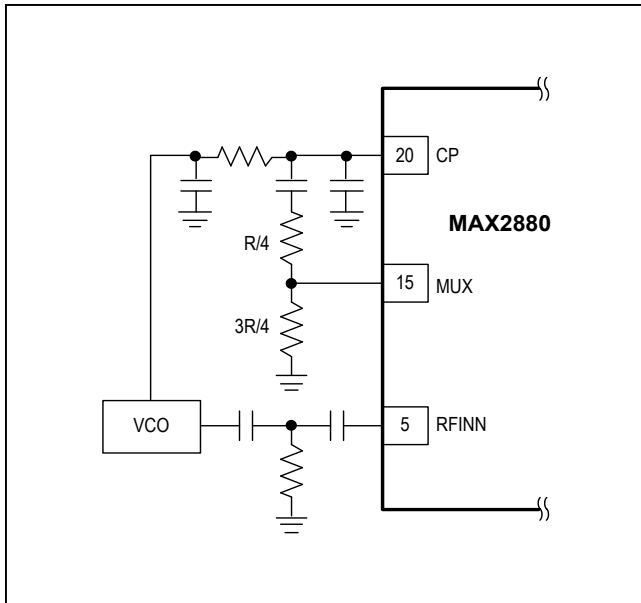

Figure 4. Fast-Lock Loop Filter Topology 1

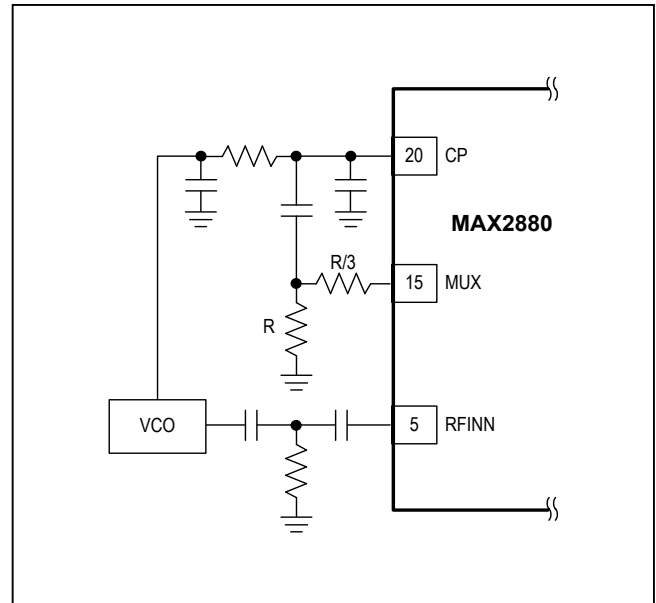

Figure 5. Fast-Lock Loop Filter Topology 2

Phase Adjustment

After achieving lock, the phase of the RF output can be changed in increments of P (register 1, bits 14:3)/ M (register 2, bits 14:3) $\times 360^\circ$.

When aligning the phase of multiple devices, connect their MUX pins together and do the following:

- 1) Force the voltage on the MUX pins to V_{IL} .
- 2) Set MUX = 1000.
- 3) Program the MAX2880s for the desired frequency and allow them to lock.
- 4) Force the voltage on the MUX pins to V_{IH} . This resets the MAX2880s so they are synchronous.
- 5) Set P (register 1, bits 14:3) for the desired amount of phase shift for each part.
- 6) Set CDM bits (register 4, bits 20:19) = 10. This enables the phase shift.
- 7) Reset CDM = 00.

Fractional Modes

The MAX2880 offers three modes for the sigma-delta modulator. Low noise mode offers lower in-band noise at the expense of spurs, and the low-spur modes offer lower spurs at the expense of noise. To operate in low noise

mode, set SDN bits to 00 (register 2, bits 30:29). In the low-spur mode, choose between two possible dithering modes (SDN = 10 or 11) for the optimal spur performance.

Temperature Sensor

The device is equipped with an on-chip temperature sensor and 7-bit ADC.

To read the digitized output of the temperature sensor:

- 1) Set CDM = 11 to enable the ADC clock.
- 2) Set $CDIV = f_{PFD}/100kHz$. If the result is not an integer, then round down to the nearest integer.
- 3) Set ADCM (register 4, bits 6:4) = 001 for temperature sensor mode.
- 4) Set ADCS (register 4, bit 3) = 1 to start the ADC.
- 5) Wait at least 100 μs for the ADC to convert the temperature.
- 6) Set MUX = 0111 to read the temperature out of the MUX pin.
- 7) Read back register 6. Bits 9:3 are the ADC digitized value.

The temperature can be converted as:

$$t = -1.8 \times ADC + 129^\circ C$$

Register and Bit Descriptions

The operating mode of the MAX2880 is controlled via 5 read/write on-chip registers and 1 read-only register.

Defaults are not guaranteed upon power-up and are provided for reference only. All reserved bits should only be written with default values. In shutdown mode, the register values are retained.

Table 5. Register 0 (Address: 000, Default: 383C0000 Hex)

BIT LOCATION	BIT ID	NAME	DEFINITION
31	READ	READ	0 = Write to register 1 = Read from register
30:27	MUX[3:0]	MUX Mode	Sets MUX Pin Configuration 0000 = High-Impedance Output 0001 = D_VDD 0010 = D_GND 0011 = R Divider Output 0100 = N Divider Output 0101 = Analog Lock Detect 0110 = Digital Lock Detect 0111 = SPI Output 1000 = SYNC input 1001 = Reserved 1010 = Reserved 1011 = Reserved 1100 = Fast Lock 1101 = R Divider/2 1110 = N Divider/2 1111 = Reserved
26:15	N[11:0]	Integer Division Value	Sets integer part (N divider) of the feedback divider factor. MSBs are located in register 1. All integer values from 16 to 65,535 are allowed for integer mode. Integer values from 19 to 4091 are allowed for fractional mode.
14:3	F[11:0]	Fractional Division Value	Sets Fractional Value. Allowed F values are 0 to M-1. 000000000000 = 0 (see F01 bit description) 000000000001 = 1 ---- 111111111110 = 4094 111111111111 = 4095
2:0	ADDR[2:0]	Address Bits	Register address bits

Table 6. Register 1 (Address: 001, Default: 00000001 Hex)

BIT LOCATION	BIT ID	NAME	DEFINITION
31	READ	Register Read	0 = Write to register 1 = Read from register
30:27	N[15:12]	Integer Division Value	Sets Integer part (N divider) of the feedback divider factor. LSBs are located in register 0. All integer values from 16 to 65,535 are allowed for integer mode. Integer values from 19 to 4091 are allowed for fractional mode.
26	Unused	Unused	Set to 0
25	PRE	RF Input Prescaler	Sets RF Input prescaler to divide-by-1 or divide-by-2 0 = Divide-by-1 (250MHz to 6.2GHz) 1 = Divide-by-2 (6.2GHz to 12.4GHz)
24:20	Unused	Unused	Set to all 0's.
19:15*	R[9:5]	Reference Divider Mode	Sets Reference Divide Value (R). LSBs located in register 2. 0000000000 = 0 (Unused) 0000000001 = 1 ----- 1111111111 = 1023
14:3	P[11:0]	Phase Value	Sets Phase Value. See the <i>Phase Adjustment</i> section 000000000000 = 0 000000000001 = 1 ----- 111111111111 = 4095
2:0	ADDR[2:0]	Address Bits	Register address bits

*Bits double buffered by Register 0.

Table 7. Register 2 (Address: 010, Default: 0000FFFA Hex)

BIT LOCATION	BIT ID	NAME	DEFINITION
31	READ	Register Read	0 = Write to register 1 = Read from register
30:29	SDN[1:0]	Fractional-N Modes	Sets Noise Mode (see the <i>Fractional Modes</i> section under the <i>Detailed Description</i>): 00 = Low-Noise Mode 01 = Reserved 10 = Low-Spur Mode 1 11 = Low-Spur Mode 2
28	CSR	Cycle Slip Reduction	0 = Cycle Slip Reduction disabled 1 = Cycle Slip Reduction enabled

Table 7. Register 2 (Address: 010, Default: 0000FFFA Hex) (continued)

BIT LOCATION	BIT ID	NAME	DEFINITION
27:24	CP[3:0]	Charge-Pump Current	Sets Charge-Pump Current [[ICP = 1.63/RSET x (1 + CP[3:0]]]
23:22	Unused	Unused	Factory Use Only, set to 00.
21*	RDIV2	Reference Div2 Mode	Sets Reference Divider Mode 0 = Disable reference divide by 2 1 = Enable reference divide by 2
20*	DBR	Reference Doubler Mode	Sets Reference Doubler Mode 0 = Disable reference doubler 1 = Enable reference doubler
19:15*	R[4:0]	Reference Divider Mode	Sets Reference Divide Value (R). Double buffered by Register 0. MSBs located in register 1. 0000000000 = 0 (Unused) 0000000001 = 1 ----- 1111111111 = 1023
14:3*	M[11:0]	Modulus Value	Fractional Modulus value used to program f_{VCO} . See the <i>Int, Frac, Mod, And R Counter Relationship</i> section. Double buffered by register 0. 000000000000 = Unused 000000000001 = Unused 000000000010 = 2 ----- 111111111111 = 4095
2:0	ADDR	Address Bits	Register address

*Bits double buffered by Register 0.

Table 8. Register 3 (Address: 011, Default: 00000043 Hex)

BIT LOCATION	BIT ID	NAME	DEFINITION
31	READ	Register Read	0 = Write to register 1 = Read from register
30:18	Unused	Unused	Write to all 0's
17	F01	F01	Sets integer mode for F = 0. 0 = If F[11:0] = 0, then fractional-N mode is set 1 = If F[11:0] = 0, then integer-N mode is auto set
16:15	CPT[1:0]	Charge-Pump Test	Sets Charge-Pump Test Modes 00 = Normal mode 01 = Reserved 10 = Force CP into source mode 11 = Force CP into Sink mode
14	RSTSD	Sigma Delta Reset	0 = Reset Sigma Delta Modulator to known value after each write to register 0 1 = Do not reset Sigma Delta Modulator to known value after each write to register 0

Table 8. Register 3 (Address: 011, Default: 0000043 Hex) (continued)

BIT LOCATION	BIT ID	NAME	DEFINITION
13	CPOC	CP Output Clamp	Sets Charge-Pump Output Clamp Mode 0 = Disables clamping of the CP output when the CP is off. 1 = Enables the clamping of the CP output when the CP is off (improved integer-N in-band phase noise).
12:11	CPL[1:0]	CP Linearity	Sets CP Linearity Mode 00 = Disables the CP linearity mode (integer-N mode). 01 = Enables the CP linearity mode (Fractional-N mode) 10 = Enables the CP linearity mode (Fractional-N mode) 11 = Enables the CP linearity mode (Fractional-N mode)
10	INT	Integer Mode	Controls Synthesizer Integer or Fractional-N Mode 0 = Fractional-N mode 1 = Integer mode
9	LDF	Lock Detect Function	Sets Lock Detect Function 0 = Fractional-N lock detect 1 = Integer-N lock detect
8	LDS	Lock Detect Speed	Lock Detect Speed Adjustment 0 = $f_{PFD} \leq 32\text{MHz}$ 1 = $f_{PFD} > 32\text{MHz}$
7	LDP	Lock Detect Precision	Sets Lock Detect Precision 0 = 10ns 1 = 6ns
6	PDP	Phase Detector Polarity	Sets Phase Detector Polarity 0 = Negative (for use with inverting active loop filters) 1 = Positive (for use with passive loop filters and noninverting active loop filters)
5	SHDN	Shutdown Mode	Sets Power-Down Mode 0 = Normal mode 1 = Device shutdown
4	TRI	Charge-Pump High-Impedance Mode	Sets Charge-Pump High-Impedance Mode 0 = Disabled 1 = Enabled
3	RST	Counter Reset	Sets Counter Reset Mode 0 = Normal operation 1 = R and N counters reset
2:0	ADDR[2:0]	Address Bits	Register address

Table 9. Register 4 (Address: 100, Default: 00000004 Hex)

BIT LOCATION	BIT ID	NAME	DEFINITION
31	READ	Register Read	0 = Write to register 1 = Read from register
30:22	Unused	Unused	Write to all 0's
21	SDREF	Shutdown Reference	Shutdown Reference Stage 0 = Reference Stage enabled 1 = Reference Stage disabled
20:19	CDM[1:0]	Clock-Divider Mode	Sets Clock-Divider Mode 00 = Clock Divider Off 01 = Fast-Lock Enabled 10 = Phase Adjustment 11 = ADC Clock
18:7	CDIV[11:0]	Clock-Divider Value	Sets 12-Bit Clock-Divider Value 000000000000 = Unused 000000000001 = 1 000000000010 = 2 ----- 111111111111 = 4095
6:4	ADCM[2:0]	ADC Mode	Sets Analog-to-Digital Converter Mode 000 = ADC off 001 = Temperature Sensor 010 - 111 = Unused
3	ADCS	ADC Start Conversion	Starts Analog-to-Digital Conversion 0 = ADC Disabled 1 = Start ADC Conversion

Table 10. Register 6 (Read-Only Register)

BIT LOCATION	BIT ID	NAME	DEFINITION
31	READ	READ	0 = N/A 1 = Read from register
30:13	Unused	Unused	
11	POR	Power on Reset	POR Readback Status 0 = POR has been read back 1 = POR has not been read back (registers at default)
10	ADCV	ADC Data Valid	ADC Data Valid 0 = ADC converting 1 = ADC data valid
9:3	ADC[6:0]	ADC Output Value	
2:0	ADDR[2:0]	Register Address	Register address bits

Typical Application Circuits

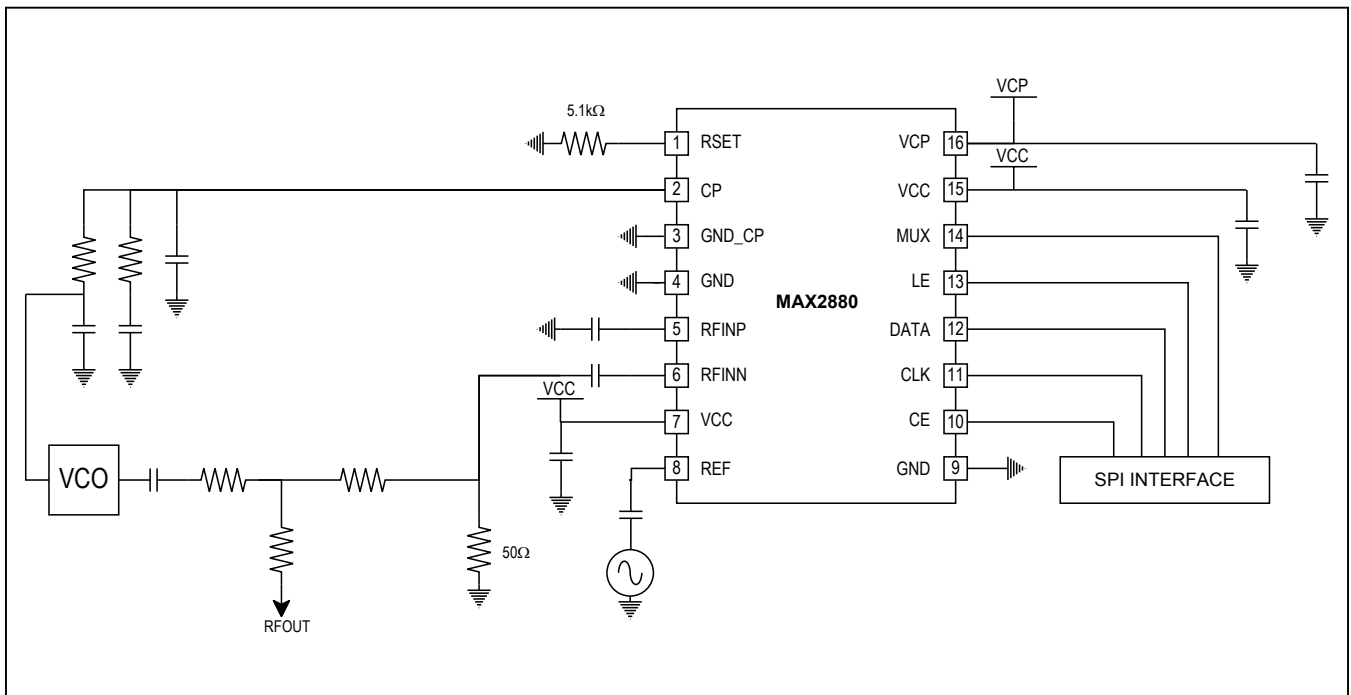
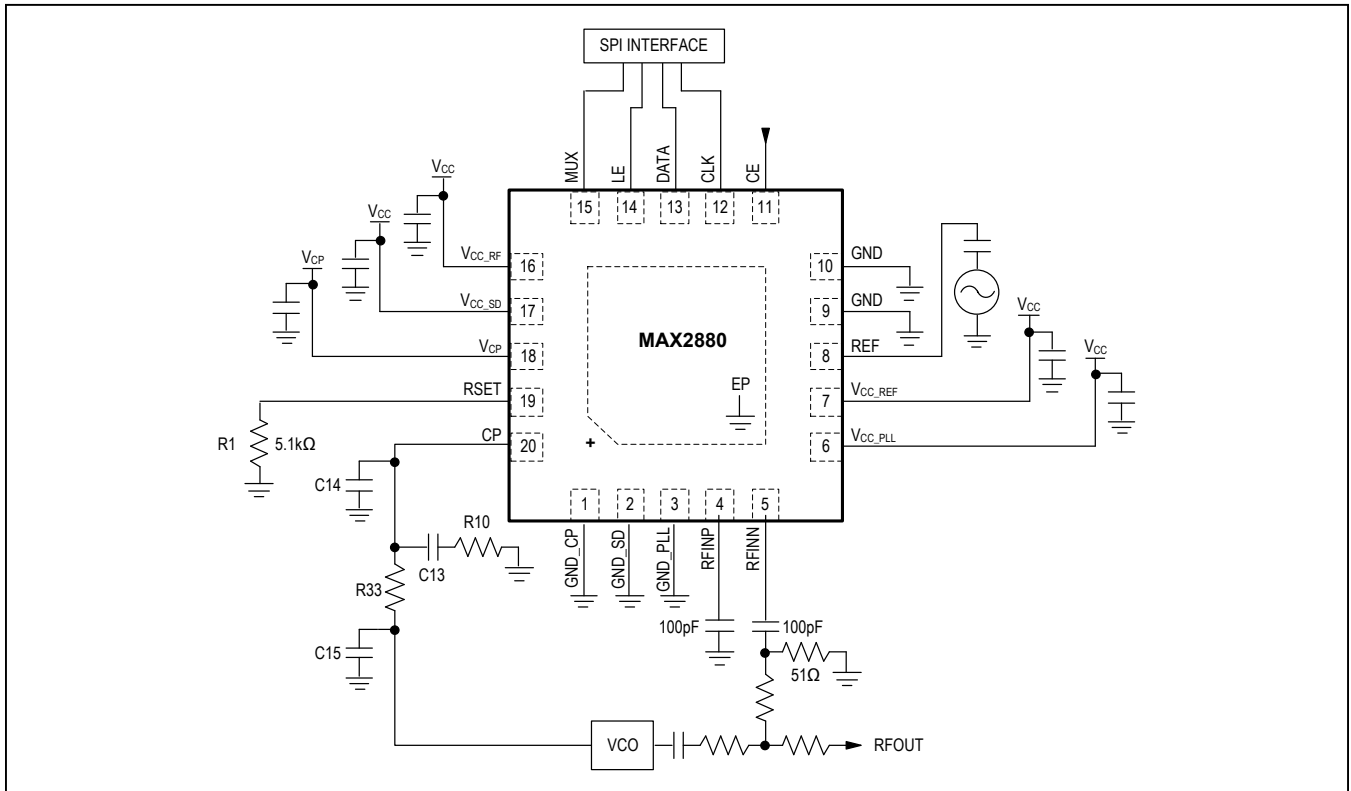

Ordering Information

PART	TEMP RANGE	PIN-PACKAGE
MAX2880ETP+	-40°C to +85°C	20 TQFN-EP*
MAX2880EUE+	-40°C to +85°C	16 TSSOP

+Denotes lead(Pb)-free/RoHS-compliant package.

*EP = Exposed pad.

Package Information

For the latest package outline information and land patterns (footprints), go to www.maximintegrated.com/packages. Note that a "+", "#", or "-" in the package code indicates RoHS status only. Package drawings may show a different suffix character, but the drawing pertains to the package regardless of RoHS status.

PACKAGE TYPE	PACKAGE CODE	OUTLINE NO.	LAND PATTERN NO.
20 TQFN-EP	T2044+2	21-0139	90-0036
16 TSSOP	T16+1	21-0066	90-0117

Revision History

REVISION NUMBER	REVISION DATE	DESCRIPTION	PAGES CHANGED
0	12/13	Initial release	—
1	11/15	Added TSSOP package information and updated Table 9	1, 4, 10, 18–20

For pricing, delivery, and ordering information, please contact Maxim Direct at 1-888-629-4642, or visit Maxim Integrated's website at www.maximintegrated.com.

Maxim Integrated cannot assume responsibility for use of any circuitry other than circuitry entirely embodied in a Maxim Integrated product. No circuit patent licenses are implied. Maxim Integrated reserves the right to change the circuitry and specifications without notice at any time. The parametric values (min and max limits) shown in the Electrical Characteristics table are guaranteed. Other parametric values quoted in this data sheet are provided for guidance.