

LTC1514-3.3/LTC1514-5

ABSOLUTE MAXIMUM RATINGS

(Note 1)

V_{IN} to GND	-0.3V to 12V
V_{OUT} to GND	-0.3V to 12V
SHDN, LBI, LBO to GND	-0.3V to 12V
V_{OUT} Short-Circuit Duration	Indefinite
Operating Temperature Range	
Commercial	0°C to 70°C
Industrial	-40°C to 85°C
Storage Temperature Range	-65°C to 150°C
Lead Temperature (Soldering, 10 sec)	300°C

PACKAGE/ORDER INFORMATION

<p>TOP VIEW</p> <p>S8 PACKAGE 8-LEAD PLASTIC SO $T_{JMAX} = 125^{\circ}C, \theta_{JA} = 110^{\circ}C/W$</p>	ORDER PART NUMBER	
	LTC1514CS8-3.3 LTC1514CS8-5 LTC1514IS8-3.3 LTC1514IS8-5	
	S8 PART MARKING	
	15143	151413
	15145	151415

Consult factory for Military grade parts.

ELECTRICAL CHARACTERISTICS

$V_{IN} = 2V$ to $10V$, $SHDN = 3V$, $C1 = 0.22\mu F$, $C_{IN} = C_{OUT} = 10\mu F$, unless otherwise noted (Note 2).

PARAMETER	CONDITIONS	MIN	TYP	MAX	UNITS
V_{IN} Operating Voltage	LTC1514-3.3	● 2.0		8	V
	LTC1514-5	● 2.7		10	V
V_{OUT} (LTC1514-3.3)	$2V \leq V_{IN} \leq 8V, I_{OUT} \leq 15mA$	● 3.17	3.3	3.43	V
	$3V \leq V_{IN} \leq 8V, I_{OUT} \leq 50mA$	● 3.17	3.3	3.43	V
V_{OUT} (LTC1514-5)	$2.7V \leq V_{IN} \leq 10V, I_{OUT} \leq 15mA$	● 4.8	5	5.2	V
	$3.3V \leq V_{IN} \leq 10V, I_{OUT} \leq 50mA$	● 4.8	5	5.2	V
V_{IN} Operating Current	$V_{IN} \leq 5V, I_{OUT} = 0, SHDN = 3V$	●	60	100	μA
	$V_{IN} > 5V, I_{OUT} = 0, SHDN = 3V$	●	75	120	μA
V_{IN} Shutdown Current	$SHDN = 0V, V_{IN} \leq 5V$	●	10	20	μA
	$SHDN = 0V, V_{IN} > 5V$	●		35	μA
Output Ripple	Full Load (Note 2)		100		mV _{p-p}
Switching Frequency		● 500	650	800	kHz
LBI Trip Point	LBI Ramping Negative	● 1.110	1.145	1.180	V
LBI Trip Point Hysteresis			1		%
LBI Input Current	LBI = 1.145V	● -50		50	nA
LBO V_{OL}	$I_{SINK} = 100\mu A, V_{IN} = 3V$	●	0.025	0.4	V
LBO Leakage Current	$V_{LBO} = 5V, LBI = V_{IN}$	● -1		1	μA
SHDN Input Threshold	V_{IL}	● 0.4	1		V
	V_{IH}	●	1	1.6	V
SHDN Input Current	$SHDN = V_{IN}$	● -1		1	μA
	$SHDN = 0V$	● -1		1	μA
I_{OUT} Short-Circuit Current	$V_{OUT} = 0V$	●	12	40	mA
t_{ON}	Soft Start Turn-On Time		4		ms

The ● denotes specifications which apply over the full operating temperature range.

Note 2: For $V_{IN} \geq 8V$, $C_{OUT} = 22\mu F$.

Note 1: Absolute Maximum Ratings are those values beyond which the life of the device may be impaired.

TYPICAL PERFORMANCE CHARACTERISTICS

LTC1514-3.3
Efficiency vs Output Current

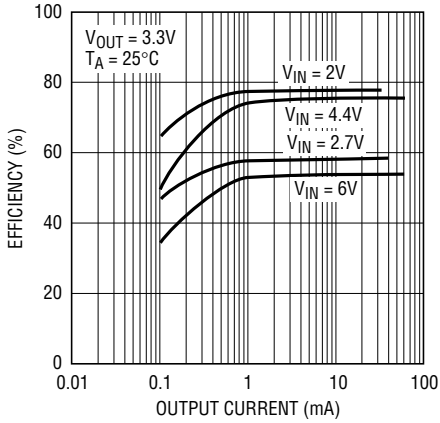

1514 G01

LTC1514-5
Efficiency vs Output Current

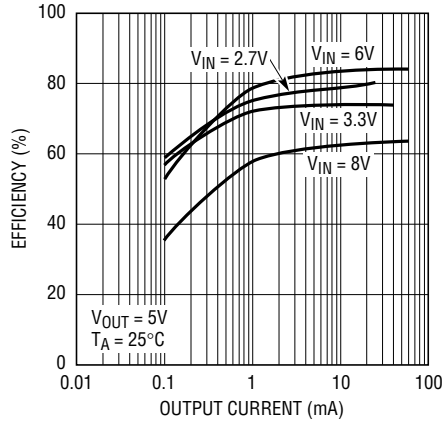

1514 G02

LTC1514-3.3 Output Voltage Ripple vs Input Voltage

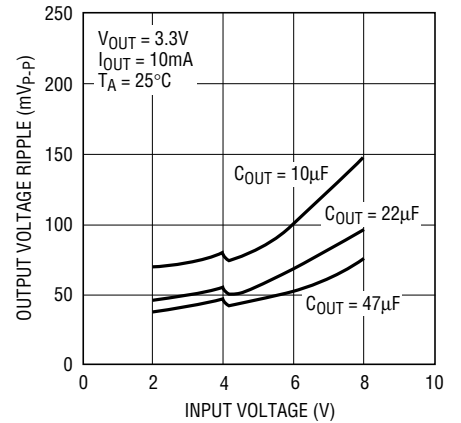

1514 G03

LTC1514-5 Output Voltage Ripple vs Input Voltage

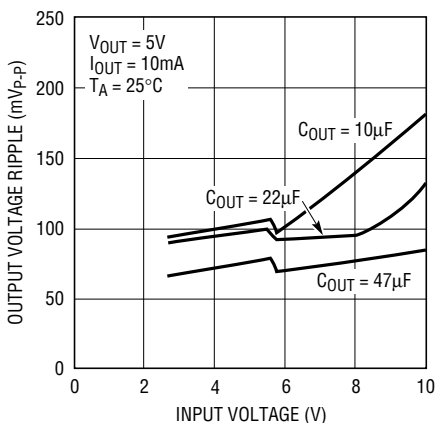

1514 G04

LTC1514-3.3 Output Voltage vs Input Voltage

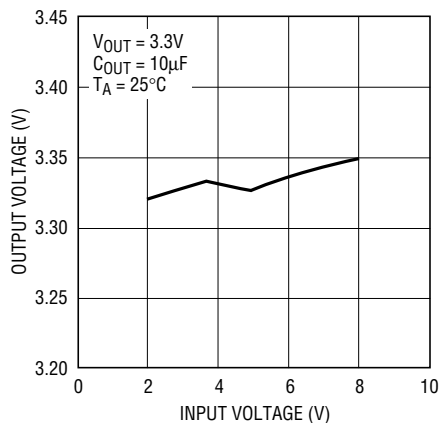

1514 G05

LTC1514-5 Operating Current vs Input Voltage

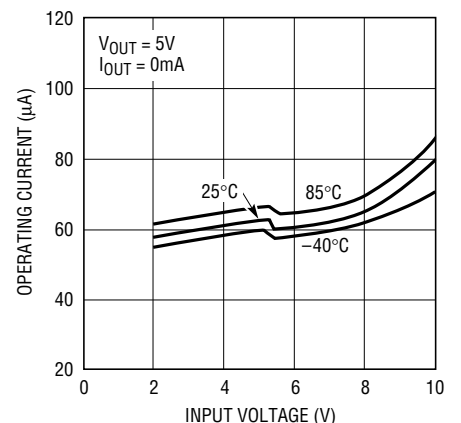

1514 G06

LTC1514-3.3
Efficiency vs Input Voltage

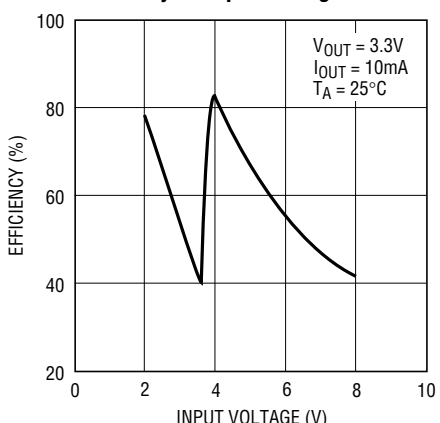

1514 G07

LTC1514-5
Efficiency vs Input Voltage

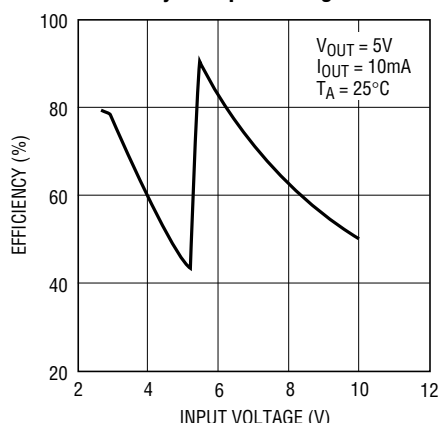

1514 G08

LTC1514-X Shutdown Supply Current vs Input Voltage

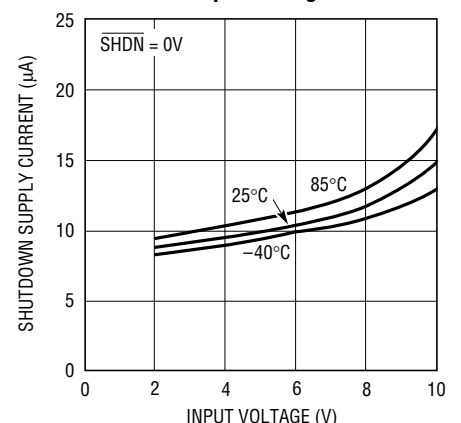

1514 G09

TYPICAL PERFORMANCE CHARACTERISTICS

LTC1514-5 Step-Down Mode Load Transient Response

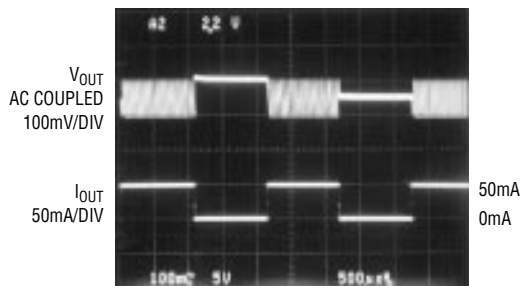

$V_{IN} = 8V, V_{OUT} = 5V, C_{OUT} = 10\mu F, T_A = 25^\circ C$

1514 G10

LTC1514-5 Step-Up Mode Load Transient Response

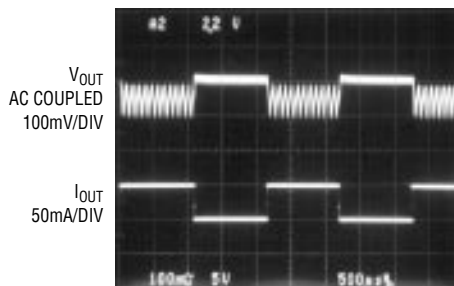

$V_{IN} = 3.3V, V_{OUT} = 5V, C_{OUT} = 10\mu F, T_A = 25^\circ C$

1514 G11

BLOCK DIAGRAM

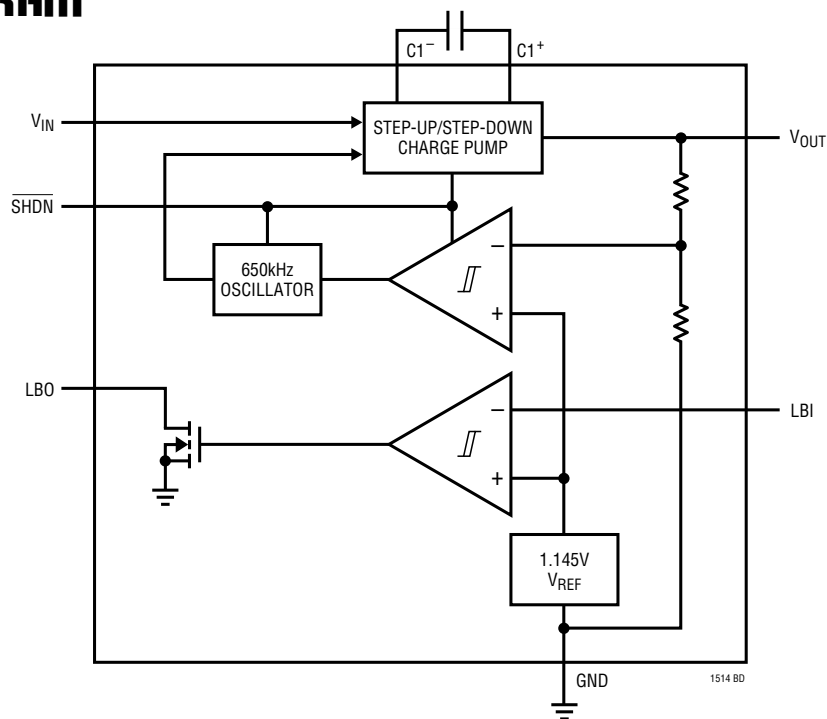

1514 B0

PIN FUNCTIONS

SHDN (Pin 1): Shutdown Input. A logic low on the SHDN pin puts the part into shutdown mode. A logic high ($V_{SHDN} \geq 1.6V$) enables the charge pump regulator. At high V_{IN} voltages, the SHDN pin may still be controlled with 3V logic without causing a large rise in V_{IN} quiescent current. The SHDN pin may not float; connect to V_{IN} if unused.

LBO (Pin 2): Open-Drain, Low-Battery Comparator Output. This pin will pull low whenever the voltage on the LBI pin is less than the internal reference voltage (1.145V typ).

LBI (Pin 3): Low-Battery Comparator Input. The voltage on this pin is compared to the internal reference voltage (1.145V). The LBO output will sink current when the voltage on the LBI pin is less than 1.145V typ. The low-

PIN FUNCTIONS

battery comparator and 1.145V reference are kept alive in shutdown.

GND (Pin 4): Ground. Should be tied to a ground plane for best performance.

C1⁻ (Pin 5): Charge Pump Flying Capacitor, Negative Terminal.

C1⁺ (Pin 6): Charge Pump Flying Capacitor, Positive Terminal.

V_{IN} (Pin 7): Charge Pump Input Voltage. May be between 2V and 8V (LTC1514-3.3) or between 2.7V and 10V (LTC1514-5). V_{IN} should be bypassed with a $\geq 10\mu\text{F}$ low ESR capacitor as close as possible to the pin for best performance.

V_{OUT} (Pin 8): Regulated Output Voltage. The output voltage is internally set to either 3.3V (LTC1514-3.3) or to 5V (LTC1514-5) using an internal resistor divider. V_{OUT} should be bypassed with a $\geq 10\mu\text{F}$ low ESR capacitor as close as possible to the pin for best performance.

APPLICATIONS INFORMATION

Regulator Operation

The regulator section of the LTC1514-3.3/LTC1514-5 consists of a charge pump, reference, comparator and some logic. The divided down output voltage is compared to the internal reference voltage. When the divided output drops below the reference voltage, the charge pump is enabled, which boosts the output back into regulation. Hysteresis in the comparator forces the regulator to burst on and off and causes approximately 100mV of peak-to-peak ripple to appear at the output. By enabling the charge pump only when needed, the LTC1514-3.3 and LTC1514-5 are able to achieve high efficiencies with low output load currents.

Each part's charge pump has a unique architecture that allows the input voltage to be either stepped up or stepped down to produce a regulated output. Internal circuitry senses the V_{IN} to V_{OUT} differential voltage and controls the charge pump operating mode. In addition, the effective output impedance of the charge pump is internally adjusted to prevent large inrush currents and allow for a wide input voltage range. When the input voltage is lower than the output voltage, the charge pump operates as a step-up voltage doubler. When the input voltage is greater than the output, the charge pump operates as a step-down gated switch.

Capacitor Selection

For best performance, low ESR capacitors are recommended for both C_{IN} and C_{OUT} to reduce noise and ripple. The C_{IN} and C_{OUT} capacitors should be either ceramic or

tantalum and should be 10 μF or greater. If the input source impedance is very low ($< 0.5\Omega$), C_{IN} may not be needed. Increasing the size of C_{OUT} to 22 μF or greater will reduce output voltage ripple—particularly with high V_{IN} voltages (8V or greater). A ceramic capacitor is recommended for the flying capacitor C1 with a value of 0.1 μF or 0.22 μF . Smaller value flying capacitors may be used in low output current applications.

Output Ripple

Normal LTC1514-3.3/LTC1514-5 operation produces voltage ripple on the V_{OUT} pin. Output voltage ripple is required for the parts to regulate. Low frequency ripple exists due to the hysteresis in the sense comparator and propagation delays in the charge pump enable/disable circuits. High frequency ripple is also present mainly from the ESR (equivalent series resistance) in the output capacitor. Typical output ripple (V_{IN} < 8V) under maximum load is 100mV peak-to-peak with a low ESR ($< 0.5\Omega$) 10 μF output capacitor. For applications requiring V_{IN} to exceed 8V, a 22 μF or larger C_{OUT} capacitor is recommended to maintain max ripple in the 100mV range.

The magnitude of the ripple voltage depends on several factors. High input voltages increase the output ripple since more charge is delivered to C_{OUT} per charging cycle. A large C1 flying capacitor ($> 0.22\mu\text{F}$) also increases ripple in step-up mode for the same reason. Large output current load and/or a small output capacitor ($< 10\mu\text{F}$) results in higher ripple due to higher output voltage dV/dt. High ESR capacitors (ESR $> 0.5\Omega$) on the

APPLICATIONS INFORMATION

output pin cause high frequency voltage spikes on V_{OUT} with every clock cycle.

There are several ways to reduce the output voltage ripple. A larger C_{OUT} capacitor (22 μ F or greater) will reduce both the low and high frequency ripple due to the lower C_{OUT} charging and discharging dV/dt and the lower ESR typically found with higher value (larger case size) capacitors. A low ESR ceramic output capacitor will minimize the high frequency ripple, but will not reduce the low frequency ripple unless a high capacitance value is chosen. A reasonable compromise is to use a 10 μ F to 22 μ F tantalum capacitor in parallel with a 1 μ F to 3.3 μ F ceramic capacitor on V_{OUT} to reduce both the low and high frequency ripple. An RC or LC filter may also be used to reduce high frequency voltage spikes (see Figure 1).

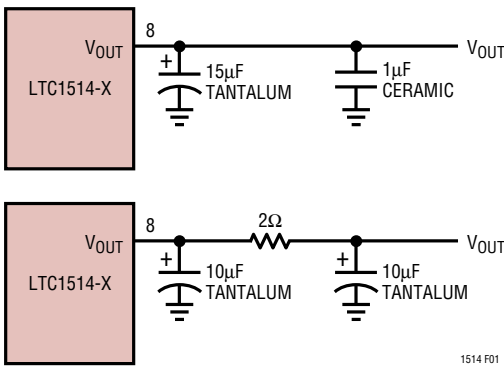

Figure 1. Output Ripple Reduction Techniques

Inrush Currents

A common problem with switched capacitor regulators is inrush current—particularly during power-up and coming out of shutdown mode. Whenever large V_{IN} (or boosted V_{IN}) to V_{OUT} voltage differentials are present, most charge pumps will pull large current spikes from the input supply. Only the effective charge pump output impedance limits the current while the charge pump is enabled. This may disrupt input supply regulation, especially if the input supply is a low power DC/DC converter or linear regulator. The LTC1514-3.3/LTC1514-5 minimize inrush currents both at start-up and under normal high V_{IN} to V_{OUT} operation.

Internal soft start circuitry controls the rate at which V_{OUT} may be charged from 0V to its final regulated value. The typical start-up time from $V_{OUT} = 0V$ to 5V is 4ms. This corresponds to an effective V_{OUT} charging current of only 12.5mA for a 10 μ F output capacitor (27.5mA for 22 μ F, etc). Note that any output current load present during start-up will add directly to the charging currents mentioned above. The soft start circuitry limits start-up current both at initial power-up and when coming out of shutdown.

As the V_{IN} (or boosted V_{IN}) to V_{OUT} voltage differential grows, the effective output impedance of the charge pump is automatically increased by internal voltage sensing circuitry. This feature minimizes the current spikes pulled from V_{IN} whenever the charge pump is enabled and helps to reduce both input and output ripple.

Protection Features

The LTC1514-X contain thermal shutdown and short-circuit protection features. The parts will shut down when the junction temperature reaches approximately 150°C and will resume operation once the junction temperature has dropped back to approximately 140°C. The parts will limit output current to 12mA (typ) when a short-circuit condition ($V_{OUT} < 100mV$) exists. The parts can survive an indefinite short to GND. The LTC1514-X devices use a low thermal resistance SO-8 package (110°C/W vs 150°C/W for standard SO-8). This permits full output current, even at high input supply voltages.

Low-Battery Comparator

The internal low-battery comparator trips at $1.145 \pm 3\%$ (LBI ramping negative). Programming the comparator to trip at a higher voltage can easily be done with an external

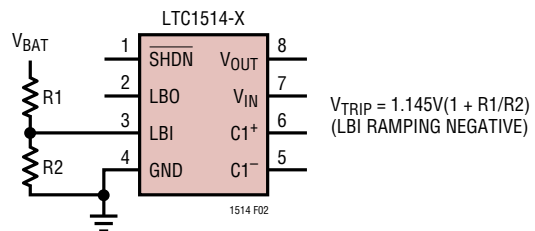

Figure 2. Programming the Low-Battery Comparator Trip Voltage

APPLICATIONS INFORMATION

resistor divider (see Figure 2). Since the low-battery comparator is kept alive in shutdown, it may be used to protect batteries against deep discharge by shutting down the power supply when the battery voltage gets too

low. The open-drain comparator output allows for flexible interfacing between the LBO output and external logic. LBO pull-up resistors in the 50k to 1M range are recommended.

TYPICAL APPLICATIONS

3.3V Step-Up/Step-Down Supply with Power Good Output

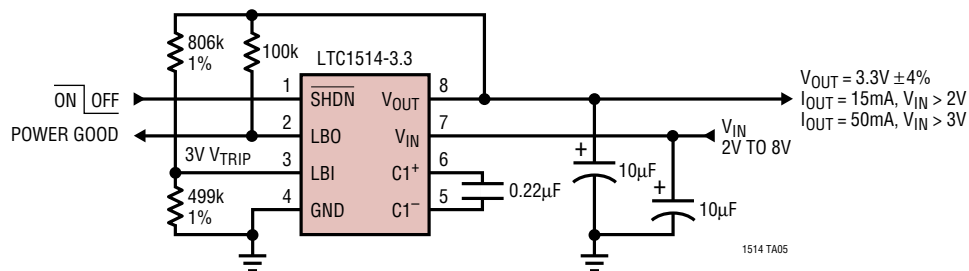

Low Power Battery Backup Supply with Autoswitchover and No Reverse Current

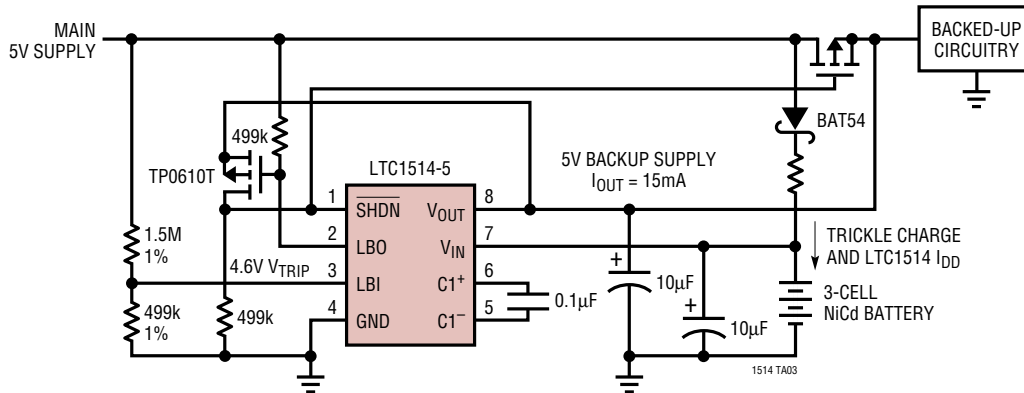

Battery/External Power Autoswitch Regulator

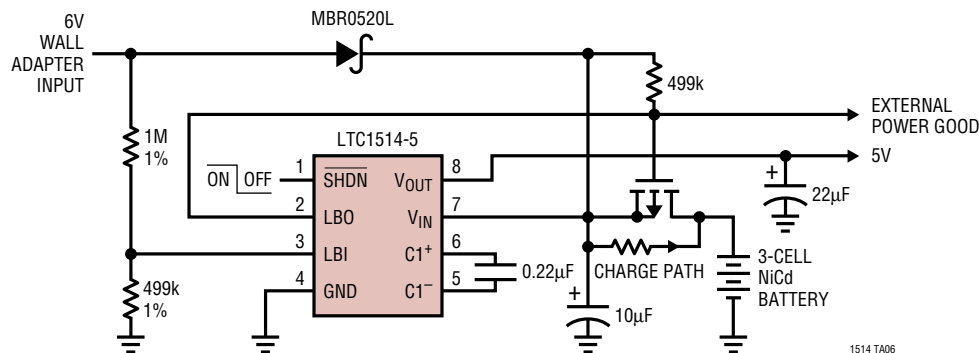

TYPICAL APPLICATIONS

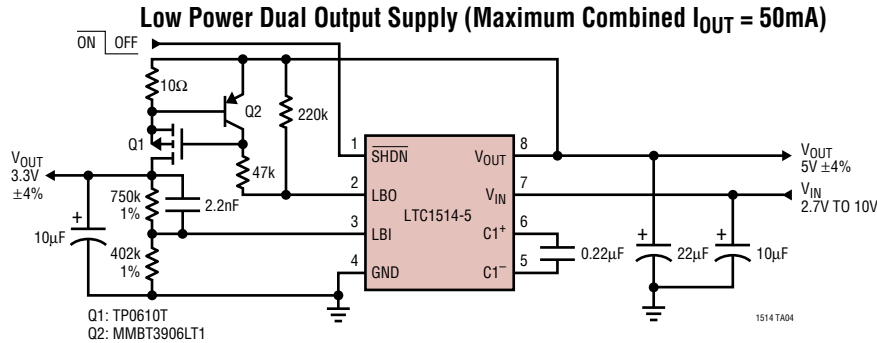

Step-Up/Step-Down Power Supply with Input Autoswitching

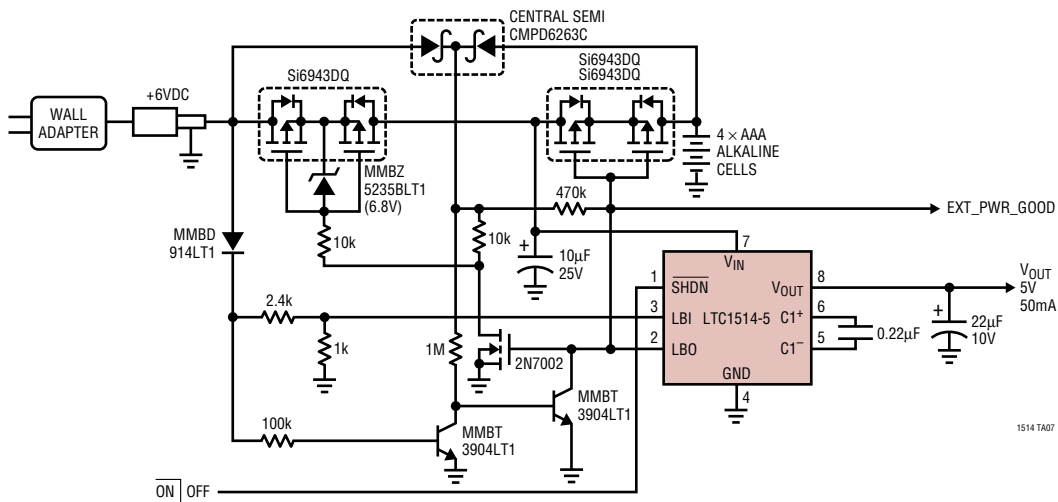

PACKAGE DESCRIPTION

Dimensions in inches (millimeters) unless otherwise noted.

S8 Package 8-Lead Plastic Small Outline (Narrow 0.150) (LTC DWG # 05-08-1610)

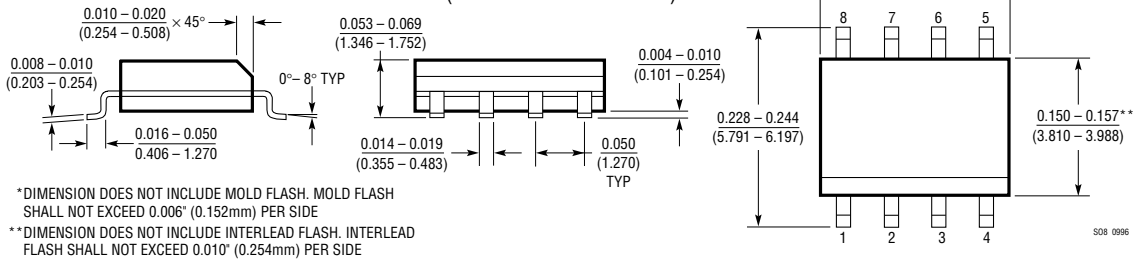

RELATED PARTS

PART NUMBER	DESCRIPTION	COMMENTS
LTC1515 Series	Step-Up/Step-Down Switched Capacitor DC/DC Converters with Reset	V_{IN} 2V to 10V, 3.3V, 5V and ADJ Versions, I_{OUT} to 50mA
LTC1516	Micropower, Regulated 5V Charge Pump DC/DC Converter	$I_{OUT} = 20mA$ ($V_{IN} \geq 2V$), $I_{OUT} = 50mA$ ($V_{IN} \geq 3V$)
LTC1517-5	Micropower, Regulated 5V Charge Pump DC/DC Converter	LTC1522 Without Shutdown and Packaged in SOT-23
LTC1522	Micropower, Regulated 5V Charge Pump DC/DC Converter	Available in 8-Pin MSOP, 6 μ A Quiescent Current, $I_{OUT} = 20mA$
LTC1555/LTC1556	SIM Power Supply and Level Translators	Step-Up/Step-Down SIM Power Supply and Level Translators
LTC660	100mA CMOS Voltage Converter	5V to -5V Conversion with Low Voltage Loss