

Contents

1. FEATURES	6
2. PIN CONFIGURATION	8
3. PIN DESCRIPTION	9
4. BLOCK DIAGRAM	10
5. BLOCK DIAGRAM DESCRIPTION	11
6. BLOCK STRUCTURE	12
7. BUS OPERATION	13
8. FUNCTIONAL OPERATION DESCRIPTION	14
8-1. READ OPERATION.....	14
8-2. PAGE READ.....	14
8-3. WRITE OPERATION.....	14
8-4. DEVICE RESET.....	14
8-5. STANDBY MODE.....	14
8-6. OUTPUT DISABLE.....	15
8-7. BYTE/WORD SELECTION.....	15
8-8. HARDWARE WRITE PROTECT.....	15
8-9. ACCELERATED PROGRAM OPERATION.....	15
8-10. WRITE BUFFER PROGRAM OPERATION.....	15
8-11. SECTOR PROTECT OPERATION.....	17
8-12. AUTOMATIC SELECT OPERATIONS.....	17
8-13. INHERENT DATA PROTECTION.....	17
8-14. COMMAND COMPLETION.....	17
8-15. LOW VCC WRITE INHIBIT.....	17
8-16. WRITE PULSE "GLITCH" PROTECTION.....	17
8-17. LOGICAL INHIBIT.....	17
8-18. POWER-UP SEQUENCE.....	18
8-19. POWER-UP WRITE INHIBIT.....	18
8-20. POWER SUPPLY DECOUPLING.....	18
9. COMMAND OPERATIONS	19
9-1. READING THE MEMORY ARRAY.....	19
9-2. AUTOMATIC PROGRAM OF THE MEMORY ARRAY.....	19
9-3. ERASING THE MEMORY ARRAY.....	21
9-4. SECTOR ERASE.....	21
9-5. CHIP ERASE.....	23
9-6. ERASE SUSPEND/RESUME.....	24
9-7. SECTOR ERASE RESUME.....	24
9-8. PROGRAM SUSPEND/RESUME.....	24
9-9. PROGRAM RESUME.....	24
9-10. BLANK CHECK.....	25

9-11. BUFFER WRITE ABORT	26
9-12. PROGRAM/ERASE STATUS CHECKING METHOD	26
9-13. STATUS REGISTER.....	31
9-14. AUTOMATIC SELECT OPERATIONS.....	32
9-15. COMMON FLASH MEMORY INTERFACE (CFI) QUERY COMMAND	34
9-16. RESET	34
9-17. ADVANCED SECTOR PROTECTION/UNPROTECTION	35
9-18. SECURITY SECTOR FLASH MEMORY REGION	41
9-19. FACTORY LOCKED: CAN BE PROGRAMMED AND PROTECTED AT THE FACTORY	41
9-20. CUSTOMER LOCKED: NOT PROGRAMMED AND NOT PROTECTED AT FACTORY.....	41
10. COMMAND REFERENCE SUMMARY	42
10-1. COMMAND DEFINITIONS	42
10-2. COMMON FLASH MEMORY INTERFACE (CFI) MODE	45
11. ELECTRICAL CHARACTERISTICS	48
11-1. ABSOLUTE MAXIMUM STRESS RATINGS	48
11-2. OPERATING TEMPERATURE AND VOLTAGE	48
11-3. TEST CONDITIONS	49
11-4. DC CHARACTERISTICS.....	50
11-5. AC CHARACTERISTICS	52
11-6. WRITE COMMAND OPERATION	54
11-7. READ/RESET OPERATION	56
11-8. ERASE/PROGRAM OPERATION	61
11-9. WRITE STATUS OPERATION.....	65
11-10. RECOMMENDED OPERATING CONDITIONS	67
11-11. ERASE AND PROGRAM PERFORMANCE	69
11-12. DATA RETENTION	69
11-13. LATCH-UP CHARACTERISTICS	69
11-14. PIN CAPACITANCE	70
12. ORDERING INFORMATION.....	71
13. PART NAME DESCRIPTION	72
14. PACKAGE INFORMATION	73
15. REVISION HISTORY	75

Figures

Figure 1. WRITE BUFFER PROGRAM FLOWCHART	16
Figure 2. AUTOMATIC PROGRAMMING ALGORITHM FLOWCHART	20
Figure 3. AUTOMATIC SECTOR ERASE ALGORITHM FLOWCHART	22
Figure 4. AUTOMATIC CHIP ERASE ALGORITHM FLOWCHART	23
Figure 5. PROGRAM/ERASE SUSPEND/RESUME ALGORITHM FLOWCHART	25
Figure 6. STATUS POLLING FOR WORD PROGRAM/ERASE	26
Figure 7. STATUS POLLING FOR WRITE BUFFER PROGRAM	27
Figure 8. TOGGLE BIT ALGORITHM	28
Figure 9. EXTENDED STATUS REGISTER FOR WRITE BUFFER PROGRAM	30
Figure 10. EXTENDED STATUS REGISTER FOR SECTOR ERASE	30
Figure 11. ADVANCE SECTOR PROTECTION/UNPROTECTION SPB PROGRAM ALGORITHM	35
Figure 12. LOCK REGISTER PROGRAM ALGORITHM	36
Figure 13. SPB PROGRAM ALGORITHM	38
Figure 14. MAXIMUM NEGATIVE OVERSHOOT WAVEFORM	48
Figure 15. MAXIMUM POSITIVE OVERSHOOT WAVEFORM	48
Figure 16. SWITCHING TEST CIRCUITS	49
Figure 17. SWITCHING TEST WAVEFORMS	49
Figure 18. COMMAND WRITE TIMING WAVEFORM (WE# CONTROLLED)	54
Figure 19. COMMAND WRITE TIMING WAVEFORM (CE# CONTROLLED)	55
Figure 20. READ TIMING WAVEFORM	56
Figure 21. PAGE READ TIMING WAVEFORM	57
Figure 22. READ MANUFACTURER ID OR DEVICE ID	58
Figure 23. RESET# TIMING WAVEFORM	59
Figure 24. DEEP POWER DOWN MODE TIMING WAVEFORM	60
Figure 25. AUTOMATIC CHIP ERASE TIMING WAVEFORM	61
Figure 26. AUTOMATIC SECTOR ERASE TIMING WAVEFORM	62
Figure 27. AUTOMATIC PROGRAM TIMING WAVEFORM	63
Figure 28. ACCELERATED PROGRAM TIMING WAVEFORM	64
Figure 29. DATA# POLLING TIMING WAVEFORM (for AUTOMATIC MODE)	65
Figure 30. TOGGLE BIT TIMING WAVEFORM	66
Figure 31. AC TIMING AT DEVICE POWER-UP	67
Figure 32. POWER UP/DOWN AND VOLTAGE DROP	68

Tables

Table 1. MX29GL512G SECTOR ARCHITECTURE	12
Table 2. MX68GL1G0G SECTOR ARCHITECTURE	12
Table 3. BUS OPERATION.....	13
Table 4. EXTENDED STATUS REGISTER	29
Table 5. STATUS REGISTER.....	31
Table 6. AUTOMATIC SELECT ID VALUE	32
Table 7. AUTOMATIC SELECT HIGH VOLTAGE OPERATION	33
Table 8. SECTOR PROTECTION STATUS TABLE.....	40
Table 9. COMMAND DEFINITIONS	42
Table 10. CFI MODE: IDENTIFICATION DATA VALUES	45
Table 11. CFI MODE: SYSTEM INTERFACE DATA VALUES.....	45
Table 12. CFI MODE: DEVICE GEOMETRY DATA VALUES.....	46
Table 13. CFI MODE: PRIMARY VENDOR-SPECIFIC EXTENDED QUERY DATA VALUES.....	47
Table 14. DC CHARACTERISTICS.....	50
Table 15. AC CHARACTERISTICS	52
Table 16. AC CHARACTERISTICS (RESET# TIMING).....	59
Table 17. AC CHARACTERISTICS (Deep Power Down Mode TIMING)	60
Table 18. AC CHARACTERISTICS (AC TIMING AT DEVICE POWER-UP).....	67
Table 19. AC CHARACTERISTICS (POWER UP/DOWN AND VOLTAGE DROP)	68
Table 20. PIN CAPACITANCE: 56-TSOP	70
Table 21. PIN CAPACITANCE: 64-LFBGA.....	70

SINGLE VOLTAGE 3V ONLY FLASH MEMORY**1. FEATURES****GENERAL FEATURES**

- Power Supply Operation
 - 2.7 to 3.6 volts for read, erase, and program operations
 - H/L: VI/O=VCC=2.7V to 3.6V, VI/O voltage must tight with VCC
 - U/D: VI/O=1.65V to 3.6V for Input/Output
- Byte/Word mode switchable
 - 512Mb: 67,108,864 x 8 / 33,554,432 x 16
 - 1Gb: 134,217,728 x 8 / 67,108,864 x 16
- 64KW/128KB uniform equal sectors architecture
- 32 byte/16 word page read buffer
- 256 word write buffer
- Extra 512 word sector for security
 - Features factory locked and identifiable, and customer lockable
- Latch-up protected to 100mA from -1V to 1.5xVcc
- Low Vcc write inhibit : $V_{cc} \leq V_{LKO}$
- Compatible with JEDEC standard
 - Pinout and software compatible to single power supply Flash

PERFORMANCE

- High Performance
 - Fast access time:
 - H/L: 100ns
 - U/D: 110ns
 - Page access time:
 - H/L: 15ns
 - U/D: 25ns
 - Word program time: 30us
 - Write Buffer Program Through: 1.8MB/Sec, 2.6MB/Sec with Accelerated Program mode
 - Sector erase time: 0.25sec
- Low Power Consumption
 - Low active read current: 12mA (typ.) at 5MHz
 - Low standby current: 512Mb/1Gb: 20/40uA (typ.)
 - Deep power down current: 3uA(typ.)
- 100,000 erase/program cycle
- 20 years data retention

SOFTWARE FEATURES

- Program/Erase Suspend & Program/Erase Resume
 - Suspends sector erase operation to read data from or program data to another sector which is not being erased
 - Suspends sector program operation to read data from another sector which is not being program
- Support Common Flash Interface (CFI)
- Advanced sector protection function (Solid and Password Protect)
- Status Register(Data Polling/Toggle), Extended Status Register(volatible bit) and Ready/Busy pin methods to determine device status
- Deep power down mode



HARDWARE FEATURES

- Ready/Busy# (RY/BY#) Output
 - Provides a hardware method of detecting program and erase operation completion
- Hardware Reset (RESET#) Input
 - Provides a hardware method to reset the internal state machine to read mode
- WP#/ACC input pin
 - Hardware write protect pin/Provides accelerated program capability
- BYTE# input pin
 - Selects 8 bits or 16 bits mode

PACKAGE

- 56-Pin TSOP
- 64-Ball LFBGA (11mm x 13mm)
- **All devices are RoHS Compliant and Halogen-free**

2. PIN CONFIGURATION

56 TSOP

Top View



64 LFBGA

Top View

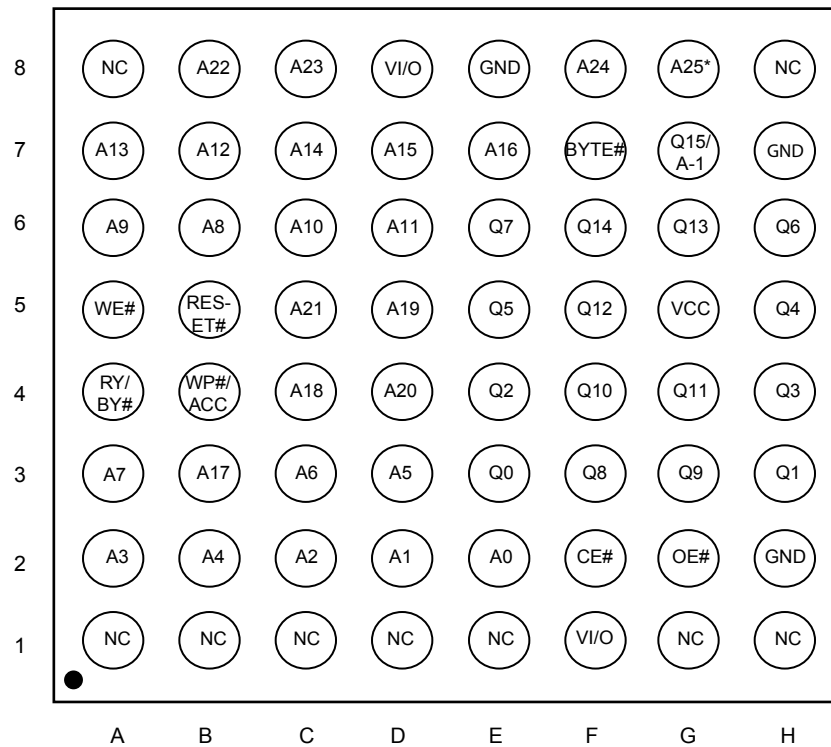

Note: * G8(A25) is NC for MX29GL512G

3. PIN DESCRIPTION

SYMBOL	PIN NAME
A0~A25	Address Input A0~A24 is for MX29GL512G A0~A25 is for MX68GL1G0G
Q0~Q14	Data Inputs/Outputs
Q15/A-1	Q15(Word Mode)/LSB addr(Byte Mode)
CE#	Chip Enable Input
WE#	Write Enable Input
OE#	Output Enable Input
RESET#	Hardware Reset Pin, Active Low
WP#/ACC *	Hardware Write Protect/Program Acceleration input
RY/BY#	Ready/Busy Output
BYTE# *	Selects 8 bits or 16 bits mode
VCC	+3.0V single power supply
GND	Device Ground
NC	Pin Not Connected Internally
VI/O	Power Supply for Input/Output

*Note: WP#/ACC and BYTE# has internal pull up.

LOGIC SYMBOL

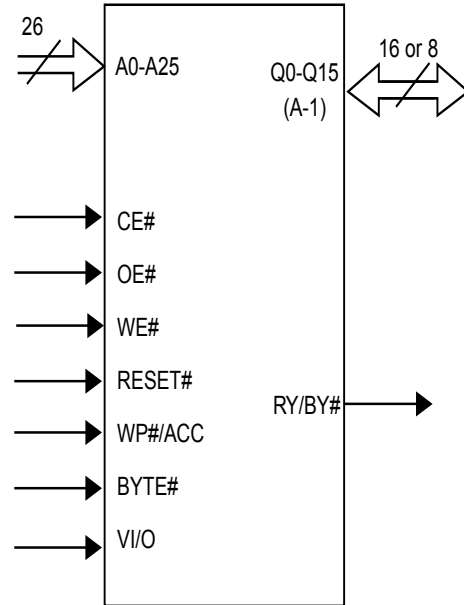

4. BLOCK DIAGRAM

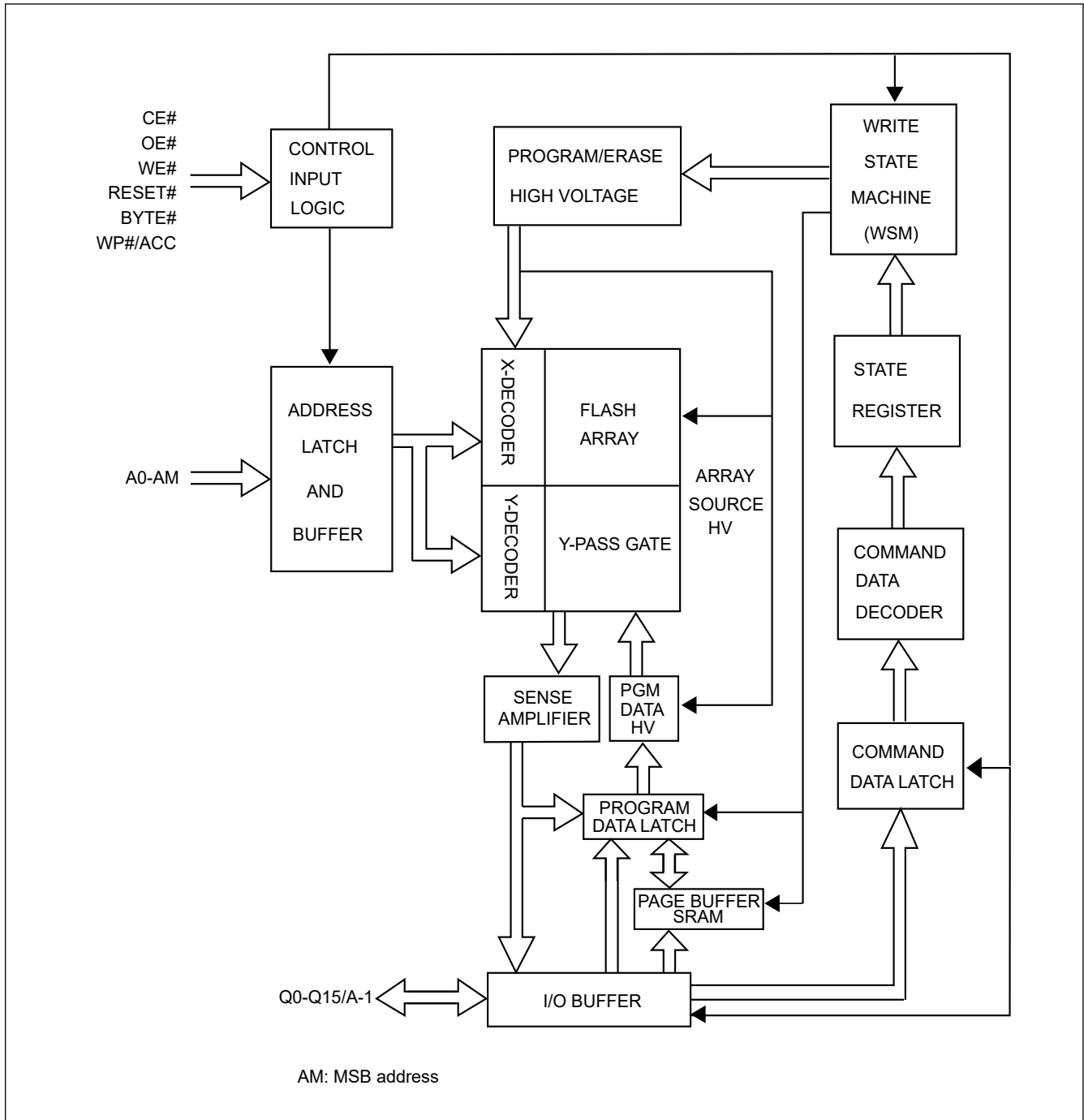

5. BLOCK DIAGRAM DESCRIPTION

The "4. [BLOCK DIAGRAM](#)" illustrates a simplified architecture of this device. Each block in the block diagram represents one or more circuit modules in the real chip used to access, erase, program, and read the memory array.

The "CONTROL INPUT LOGIC" block receives input pins CE#, OE#, WE#, RESET#, BYTE#, and WP#/ACC. It creates internal timing control signals according to the input pins and outputs to the "ADDRESS LATCH AND BUFFER" to latch the external address pins A0-AM (AM=A24 is for MX29GL512G, AM=A25 is for MX68GL1G0G). The internal addresses are output from this block to the main array and decoders composed of "X-DECODER", "Y-DECODER", "Y-PASS GATE", AND "FLASH ARRAY". The X-DECODER decodes the word-lines of the flash array, while the Y-DECODER decodes the bit-lines of the flash array. The bit lines are electrically connected to the "SENSE AMPLIFIER" and "PGM DATA HV" selectively through the Y-PASS GATES. "SENSE AMPLIFIERS" are used to read out the contents of the flash memory, while the "PGM DATA HV" block is used to selectively deliver high power to bit-lines during programming. The "I/O BUFFER" controls the input and output on the Q0-Q15/A-1 pads. During read operation, the "I/O BUFFER" receives data from SENSE AMPLIFIERS and drives the output pads accordingly. In the last cycle of program command, the "I/O BUFFER" transmits the data on Q0-Q15/A-1 to "PROGRAM DATA LATCH", which controls the high power drivers in "PGM DATA HV" to selectively program the bits in a word or byte according to the user input pattern. During write-to-buffer sequence, the "I/O BUFFER" transmits the data on Q0-Q15 to PAGE BUFFER SRAM to store user data. After user has issued the confirm command, the data in PAGE BUFFER SRAM would transmit to PROGRAM DATA LATCH sequentially and program the data to flash memory cells through PGM DATA HV.

The "PROGRAM/ERASE HIGH VOLTAGE" block comprises the circuits to generate and deliver the necessary high voltage to the X-DECODER, FLASH ARRAY, and "PGM DATA HV" blocks. The logic control module comprises of the "WRITE STATE MACHINE, WSM", "STATE REGISTER", "COMMAND DATA DECODER", and "COMMAND DATA LATCH". When the user issues a command by toggling WE#, the command on Q0-Q15/A-1 is latched in the COMMAND DATA LATCH and is decoded by the COMMAND DATA DECODER. The STATE REGISTER receives the command and records the current state of the device. The WSM implements the internal algorithms for program or erase according to the current command state by controlling each block in the block diagram.

ARRAY ARCHITECTURE

The main flash memory array can be organized as Byte mode (x8) or Word mode (x16). The details of the address ranges and the corresponding sector addresses are shown in "[6. BLOCK STRUCTURE](#)".

6. BLOCK STRUCTURE

Table 1. MX29GL512G SECTOR ARCHITECTURE

Sector Size		Sector	Sector Address A24-A16	Address Range (x16)
Kbytes	Kwords			
128	64	SA0	000000000	0000000h-000FFFFh
128	64	SA1	000000001	0010000h-001FFFFh
128	64	SA2	000000010	0020000h-002FFFFh
⋮	⋮	⋮	⋮	⋮
128	64	SA511	111111111	1FF0000h-1FFFFFFh

Table 2. MX68GL1G0G SECTOR ARCHITECTURE

Sector Size		Sector	Sector Address A25-A16	Address Range (x16)
Kbytes	Kwords			
128	64	SA0	000000000	0000000h-000FFFFh
128	64	SA1	000000001	0010000h-001FFFFh
128	64	SA2	000000010	0020000h-002FFFFh
⋮	⋮	⋮	⋮	⋮
128	64	SA1023	111111111	3FF0000h-3FFFFFFh

7. BUS OPERATION

Table 3. BUS OPERATION

Mode Select	RE-SET#	CE#	WE#	OE#	Address (Note4)	Data I/O Q7~Q0	Byte#		WP#/ACC
							Vil	Vih	
							Data (I/O) Q15~Q8		
Device Reset	L	X	X	X	X	HighZ	HighZ	HighZ	L/H
Standby Mode	$V_{cc} \pm 0.3V$	$V_{cc} \pm 0.3V$	X	X	X	HighZ	HighZ	HighZ	H
Output Disable	H	L	H	H	X	HighZ	HighZ	HighZ	L/H
Read Mode	H	L	H	L	AIN	DOUT	Q8-Q14= HighZ, Q15=A-1	DOUT	L/H
Write	H	L	L	H	AIN	DIN		DIN	<i>Note1,2</i>
Accelerate Program	H	L	L	H	AIN	DIN		DIN	Vhv

Notes:

1. The first or last sector was protected if WP#/ACC=Vil.
2. When WP#/ACC = Vih, the protection conditions of the outmost sector depends on previous protection conditions. Refer to the advanced protect feature.
3. Q0~Q15 are input (DIN) or output (DOUT) pins according to the requests of command sequence, sector protection, or data polling algorithm.
4. In Word Mode (Byte#=Vih), the addresses are AM to A0, AM: MSB of address.
In Byte Mode (Byte#=Vil), the addresses are AM to A-1 (Q15), AM: MSB of address.

8. FUNCTIONAL OPERATION DESCRIPTION

8-1. READ OPERATION

To perform a read operation, the system addresses the desired memory array or status register location by providing its address on the address pins and simultaneously enabling the chip by driving CE# & OE# LOW, and WE# HIGH. After the Tce and Toe timing requirements have been met, the system can read the contents of the addressed location by reading the Data (I/O) pins. If either the CE# or OE# is held HIGH, the outputs will remain tri-stated and no data will appear on the output pins.

8-2. PAGE READ

This device is able to conduct Macronix compatible high performance page read. Page size is 32 bytes or 16 words. The higher address Amax ~ A4 select the certain page, while A3~A0 for word mode, A3~A-1 for byte mode select the particular word or byte in a page. The page access time is Taa or Tce, following by Tpa for the rest of the page read time. When CE# toggles, access time is Taa or Tce. Page mode can be turned on by keeping "page-read address" constant and changing the "intra-read page" addresses.

8-3. WRITE OPERATION

To perform a write operation, the system provides the desired address on the address pins, enables the chip by asserting CE# LOW, and disables the Data (I/O) pins by holding OE# HIGH. The system then places data to be written on the Data (I/O) pins and pulses WE# LOW. The device captures the address information on the falling edge of WE# and the data on the rising edge of WE#. To see an example, please refer to the timing diagram in "[Figure 18. COMMAND WRITE TIMING WAVEFORM \(WE# CONTROLLED\)](#)". The system is not allowed to write invalid commands (commands not defined in this datasheet) to the device. Writing an invalid command may put the device in an undefined state.

8-4. DEVICE RESET

Driving the RESET# pin LOW for a period of Trp or more will return the device to Read mode. If the device is in the middle of a program or erase operation, the reset operation will take at most a period of Tready1 before the device returns to Read mode. Until the device does returns to Read mode, the RY/BY# pin will remain Low (Busy Status).

When the RESET# pin is held at GND±0.3V, the device only consumes standby (Isbr) current. However, the device draws larger current if the RESET# pin is held at a voltage greater than GND+0.3V and less than or equal to Vil.

It is recommended to tie the system reset signal to the RESET# pin of the flash memory. This allows the device to be reset with the system and puts it in a state where the system can immediately begin reading boot code from it.

8-5. STANDBY MODE

The device enters Standby mode whenever the RESET# and CE# pins are both held High except in the embedded mode. While in this mode, WE# and OE# will be ignored, all Data Output pins will be in a high impedance state, and the device will draw minimal (Isb) current.

8-6. OUTPUT DISABLE

While in active mode (RESET# HIGH and CE# LOW), the OE# pin controls the state of the output pins. If OE# is held HIGH, all Data (I/O) pins will remain tri-stated. If held LOW, the Byte or Word Data (I/O) pins will drive data.

8-7. BYTE/WORD SELECTION

The BYTE# input pin is used to select the organization of the array data and how the data is input/output on the Data (I/O) pins. If the BYTE# pin is held HIGH, Word mode will be selected and all 16 data lines (Q0 to Q15) will be active.

If BYTE# is forced LOW, Byte mode will be active and only data lines Q0 to Q7 will be active. Data lines Q8 to Q14 will remain in a high impedance state and Q15 becomes the A-1 address input pin.

8-8. HARDWARE WRITE PROTECT

By driving the WP#/ACC pin LOW. The highest or lowest was protected from all erase/program operations. If WP#/ACC is held HIGH (V_{ih} to VCC), these sectors revert to their previously protected/unprotected status.

8-9. ACCELERATED PROGRAM OPERATION

By applying high voltage (V_{hv}) to the WP#/ACC pin, the device will enter the Accelerated Program mode. This mode permits the system to skip the normal command unlock sequences and program byte/word locations directly. During accelerated program, the current drawn from the WP#/ACC pin is no more than I_{cp1} .

8-10. WRITE BUFFER PROGRAM OPERATION

Programs 256 word in word mode program and 256 byte in byte mode program operation. To trigger the Write Buffer Program, start by the first two unlock cycles, then third cycle writes the Write Buffer Load command at the destined program Sector Address. The fourth cycle writes the "word locations subtract one" number.

Following above operations, system starts to write the mingling of address and data. After the programming of the first address or data, the "write-buffer-page" is selected. The following data should be within the above mentioned page.

The "write-buffer-page" is selected by choosing address $A_{max} \sim A_8$.

"Write-Buffer-Page" address has to be the same for all address/data write into the write buffer. If not, operation will ABORT.

To program the content of the write buffer page this command must be followed by a write to buffer Program confirm command.

The operation of write-buffer can be suspended or resumed by the standard commands, once the write buffer program operation is finished, it'll return to normal READ mode.

ABORT will be executed for the Write Buffer Program Sequence if following condition occurs:

- The value loaded is bigger than the page buffer size during "Number of Locations to Program"
- Address written in a sector is not the same as the one assigned during the Write-Buffer-Load command.
- Address/Data pair written to a different write-buffer-page than the one assigned by the "Starting Address" during the "write buffer data loading" operation.
- Writing not "Confirm Command" after the assigned number of "data load" cycles.

At Write Buffer Abort mode, the status register will be Q1=1, Q7=DATA# (last address written), Q6=toggle. A Write-to-Buffer-Abort Reset command sequence has to be written to reset the device for the next operation.

Write buffer program can be conducted in any sequence. However the CFI functions, autoselect, Security sector are not functional when program operation is in progress. Multiple write buffer program operations on the same write buffer address range without intervening erases is available. Any bit in a write buffer address range can't be programmed from 0 back to 1.

Figure 1. WRITE BUFFER PROGRAM FLOWCHART

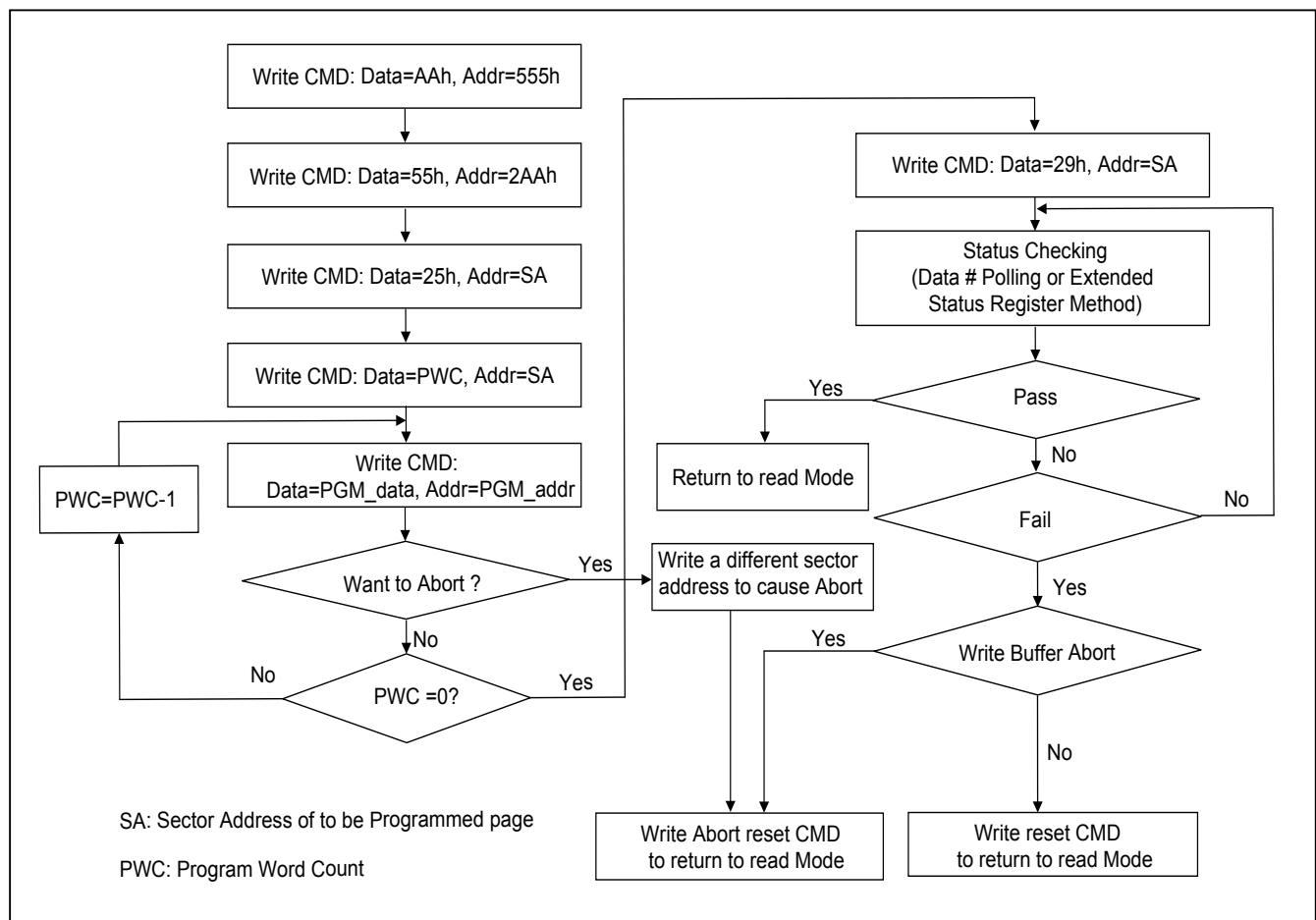

8-11. SECTOR PROTECT OPERATION

The device provides user programmable protection operations for selected sectors. Please refer to "6. BLOCK STRUCTURE" which show all Sector assignments.

During the protection operation, the sector address of any sector may be used to specify the sector being protected.

8-12. AUTOMATIC SELECT OPERATIONS

Automatic Select mode is used to access the manufacturer ID, device ID and CFI code. The automatic select mode has four command cycles. There are 2 methods to enter automatic select mode, user can issues the autoselect commands or applies the high voltage on the A9 pin. Please see AUTOMATIC SELECT OPERATIONS in the COMMAND OPERATIONS section.

8-13. INHERENT DATA PROTECTION

To avoid accidental erase or program of the device, the device is automatically reset to Read mode during power up. Additionally, the following design features protect the device from unintended data corruption.

8-14. COMMAND COMPLETION

Only after the successful completion of the specified command sets will the device begin its erase or program operation. The failure in observing valid command sets will result in the memory returning to read mode.

8-15. LOW VCC WRITE INHIBIT

The device refuses to accept any write command when Vcc is less than VLKO. This prevents data from spuriously being altered during power-up, power-down, or temporary power interruptions. The device automatically resets itself when Vcc is lower than VLKO and write commands are ignored until Vcc is greater than VLKO. The system must provide proper signals on control pins after Vcc rises above VLKO to avoid unintentional program or erase operations.

8-16. WRITE PULSE "GLITCH" PROTECTION

CE#, WE#, OE# pulses shorter than 5ns are treated as glitches and will not be regarded as an effective write cycle.

8-17. LOGICAL INHIBIT

A valid write cycle requires both CE# and WE# at Vil with OE# at Vih. Write cycle is ignored when either CE# at Vih, WE# at Vih, or OE# at Vil.

8-18. POWER-UP SEQUENCE

Upon power up, the device is placed in Read mode. Furthermore, program or erase operation will begin only after successful completion of specified command sequences.

8-19. POWER-UP WRITE INHIBIT

When WE#, CE# is held at V_{il} and OE# is held at V_{ih} during power up, the device ignores the first command on the rising edge of WE#.

8-20. POWER SUPPLY DECOUPLING

A 0.1 μ F capacitor should be connected between the Vcc and GND to reduce the noise effect.

9. COMMAND OPERATIONS

9-1. READING THE MEMORY ARRAY

Read mode is the default state after power up or after a reset operation. To perform a read operation, please refer to READ OPERATION in the BUS OPERATIONS section above.

If the device receives an Erase Suspend command while in the Sector Erase state, the erase operation will pause (after a time delay not exceeding T_{est} period) and the device will enter Erase-Suspended Read mode. While in the Erase-Suspended Read mode, data can be programmed or read from any sector not being erased. Reading from addresses within sector(s) being erased will only return the contents of the status register, which is in fact how the current status of the device can be determined.

If a program command is issued to any inactive (not currently being erased) sector during Erase-Suspended Read mode, the device will perform the program operation and automatically return to Erase-Suspended Read mode after the program operation completes successfully.

While in Erase-Suspended Read mode, an Erase Resume command must be issued by the system to reactivate the erase operation. The erase operation will resume from where it was suspended and will continue until it completes successfully or another Erase Suspend command is received.

After the memory device completes an embedded operation (automatic Chip Erase, Sector Erase, or Program) successfully, it will automatically return to Read mode and data can be read from any address in the array. If the embedded operation fails to complete, as indicated by status register bit Q5 (exceeds time limit flag) going HIGH during the operations, the system must perform a reset operation to return the device to Read mode.

There are several states that require a reset operation to return to Read mode:

1. A program or erase failure--indicated by status register bit Q5 going HIGH during the operation. Failures during either of these states will prevent the device from automatically returning to Read mode.
2. The device is in Auto Select mode or CFI mode. These two states remain active until they are terminated by a reset operation.

In the two situations above, if a reset operation (either hardware reset or software reset command) is not performed, the device will not return to Read mode and the system will not be able to read array data.

9-2. AUTOMATIC PROGRAM OF THE MEMORY ARRAY

The device provides the user the ability to program the memory array in Byte mode or Word mode. As long as the user enters the correct cycle defined in the "[Table 9. COMMAND DEFINITIONS](#)" (including 2 unlock cycles and the A0H program command), any byte or word data provided on the data lines by the system will automatically be programmed into the array at the specified location.

After the program command sequence has been executed, the internal write state machine (WSM) automatically executes the algorithms and timings necessary for program and verification, which includes generating suitable program pulses, checking cell threshold voltage margins, and repeating the program pulse if any cells do not pass verification or have low margins. The internal controller protects cells that do pass verification and margin tests from being over-programmed by inhibiting further program pulses to these passing cells as weaker cells continue to be programmed.

With the internal WSM automatically controlling the program process, the user only needs to enter the program command and data once.

Program will only change the bit status from "1" to "0". It is not possible to change the bit status from "0" to "1" by program. This can only be done by an erase operation. Furthermore, the internal write verification only checks and detects errors in cases where a "1" is not successfully programmed to "0".

Any commands written to the device during programming will be ignored except hardware reset or program suspend. Hardware reset will terminate the program operation after a period of time no more than 10us. When the embedded program algorithm is complete or the program operation is terminated by a hardware reset, the device will return to Read mode. Program suspend ready, the device will enter program suspend read mode.

Please refer to the following figure for automatic programming flowchart.

Figure 2. AUTOMATIC PROGRAMMING ALGORITHM FLOWCHART

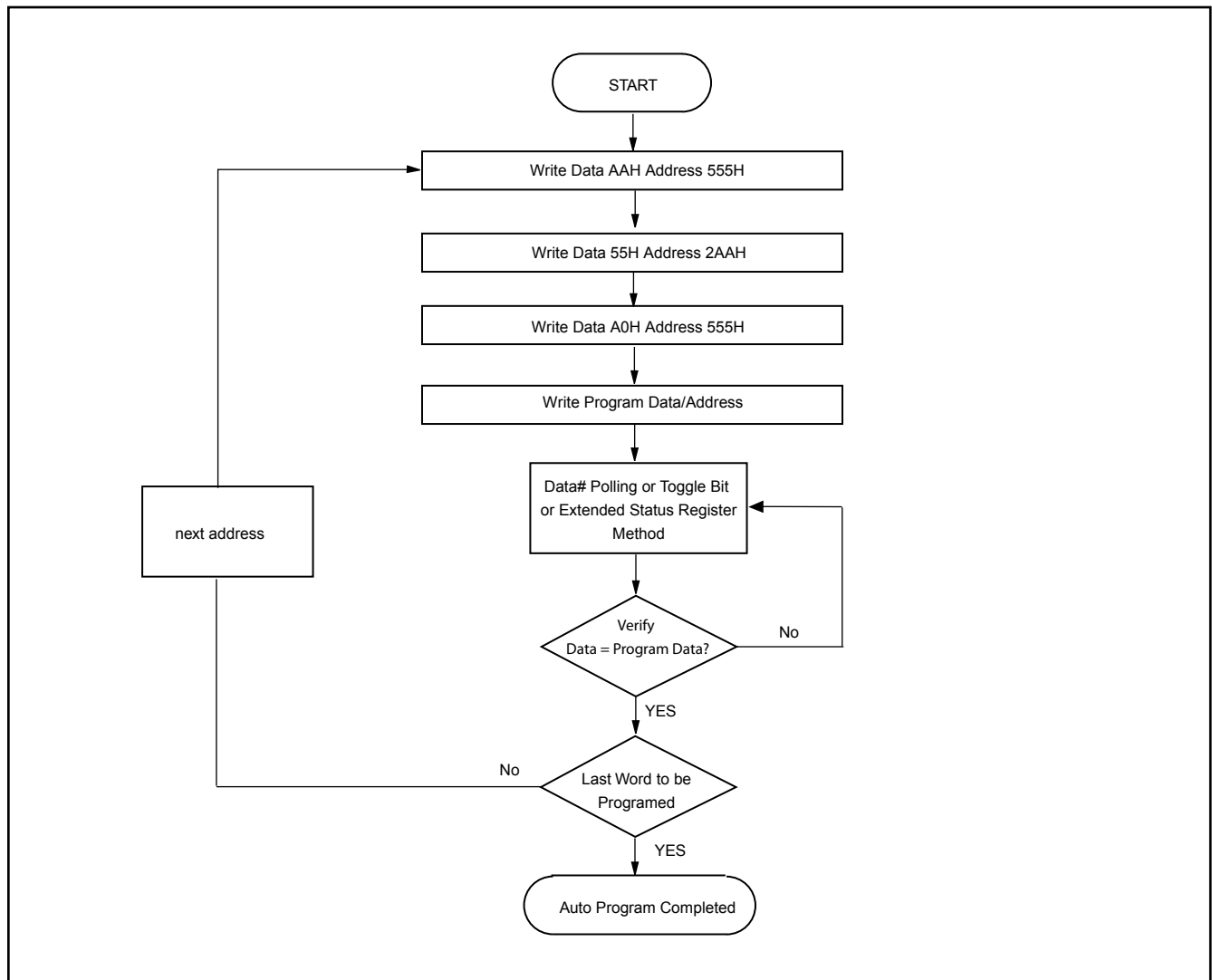

After the embedded program operation has begun, the user can check for completion by reading the following bits in the status register.

9-3. ERASING THE MEMORY ARRAY

There are two types of erase operations performed on the memory array -- Sector Erase and Chip Erase. In the Sector Erase operation, the selected sector shall be erased. In the Chip Erase operation, the complete memory array is erased except for any protected sectors. More details of the protected sectors are explained in Section ["9-17. ADVANCED SECTOR PROTECTION/UNPROTECTION"](#).

9-4. SECTOR ERASE

The sector erase operation is used to clear data within a sector by returning all of its memory locations to the "1" state. It requires six command cycles to initiate the erase operation. The first two cycles are "unlock cycles", the third is a configuration cycle, the fourth and fifth are also "unlock cycles", and the sixth cycle is the Sector Erase command.

After the embedded sector erase operation begins, all commands except Erase Suspend and Extended Status Register Read will be ignored. The only way to interrupt the operation is with an Erase Suspend command or with a hardware reset. The hardware reset will completely abort the operation and return the device to Read mode. Please refer to the following figure for sector erase flowchart.

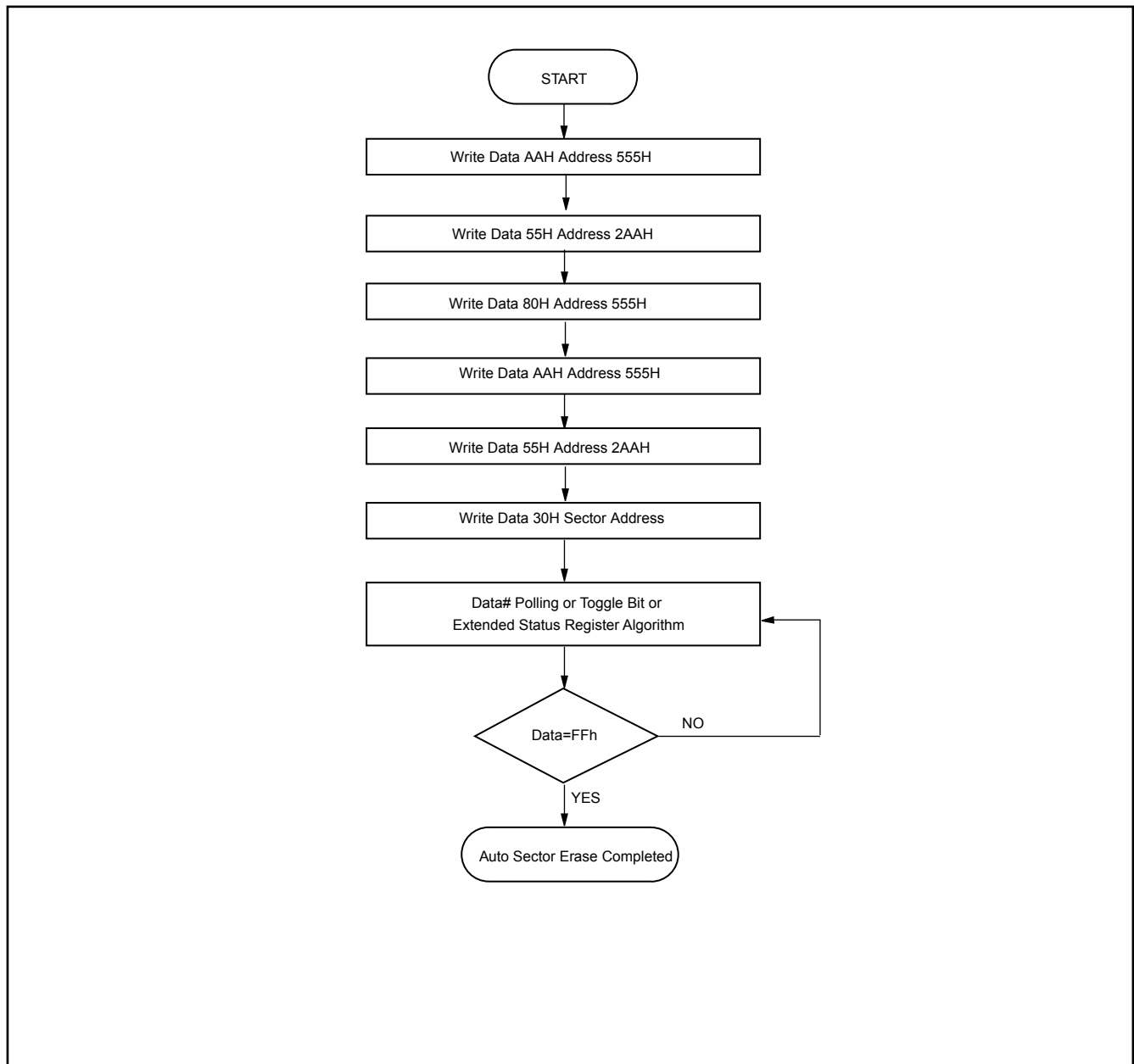
Figure 3. AUTOMATIC SECTOR ERASE ALGORITHM FLOWCHART

The system can determine the status of the automatic sector erase operation by the status register, see the STATUS REGISTER for the details.

9-5. CHIP ERASE

The Chip Erase operation is used to erase all the data within the memory array. All memory cells containing a "0" will be returned to the erased state of "1". This operation requires 6 write cycles to initiate the action. The first two cycles are "unlock" cycles, the third is a configuration cycle, the fourth and fifth are also "unlock" cycles, and the sixth cycle initiates the chip erase operation.

During the chip erase operation, no other software commands will be accepted, but if a hardware reset is received or the working voltage is too low, that chip erase will be terminated. After Chip Erase, the chip will automatically return to Read mode. See following figure for chip erase flowchart.

Figure 4. AUTOMATIC CHIP ERASE ALGORITHM FLOWCHART

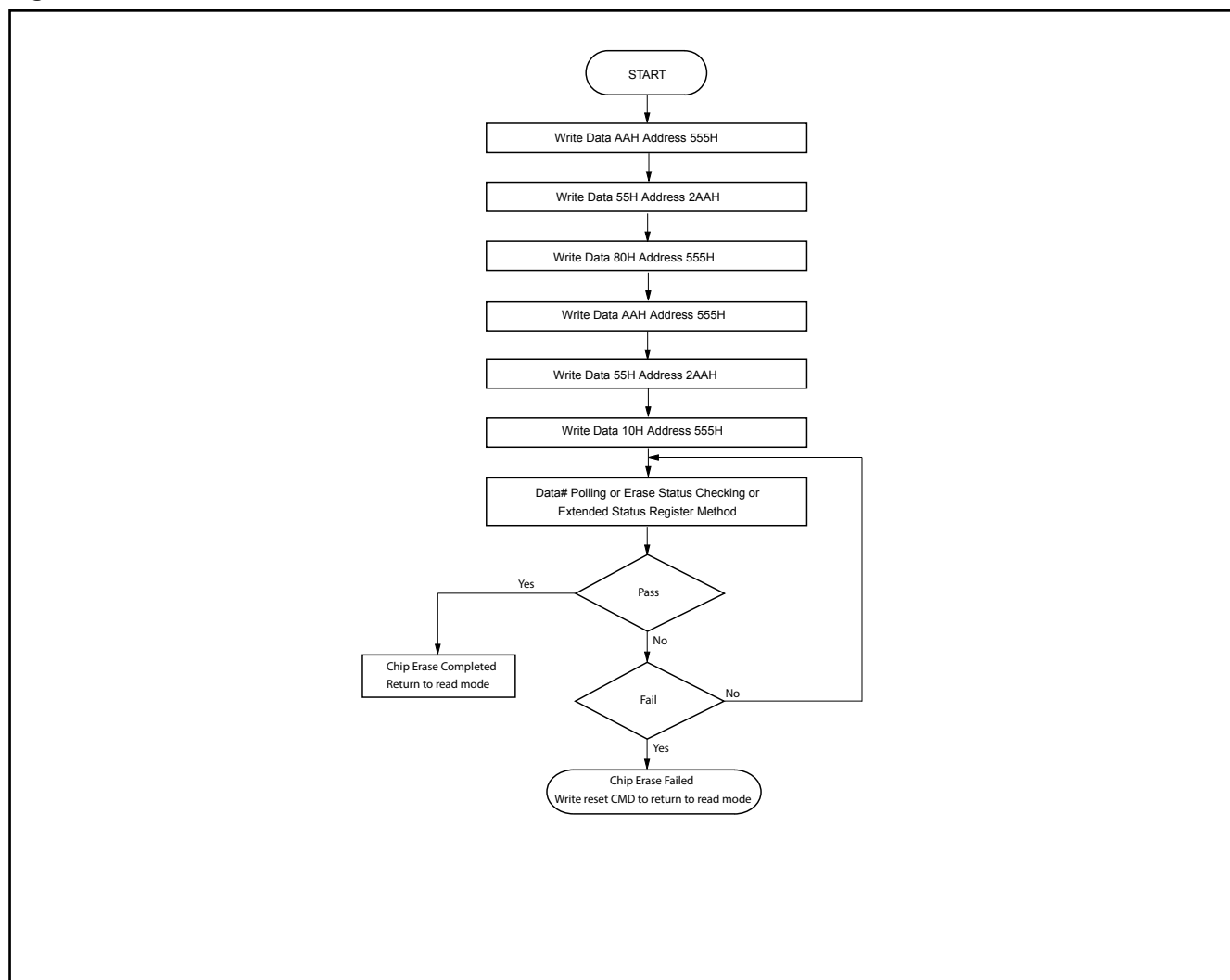

The system can determine the status of the embedded chip erase operation by the status register, see the STATUS REGISTER for the details.

9-6. ERASE SUSPEND/RESUME

After beginning a sector erase operation, Erase Suspend and read Extended Status Register are the valid commands that may be issued. If the system issues an Erase Suspend command after the sector erase operation has already begun, the device will not enter Erase-Suspended Read mode until T_{esl} period has elapsed. The system can determine if the device has entered the Erase-Suspended Read mode through Q6, Q7, and RY/BY# of Status Register or Extended Status Register.

After the device has entered Erase-Suspended Read mode, the system can read or program any sector (s) except this suspended sector. Reading this sector being erased will return the contents of status register. Whenever a suspend command is issued, user must issue a resume command and check Q6 toggle bit status, before issue another erase command. See following figure for erase suspend/resume flowchart.

9-7. SECTOR ERASE RESUME

The sector Erase Resume command is valid only when the device is in Erase-Suspended Read mode. After erase resumes, the user can issue another Erase Suspend command, but there should be a T_{ers} interval between Erase Resume and the next Erase Suspend command.

9-8. PROGRAM SUSPEND/RESUME

After beginning a program operation, Program Suspend and read Extended Status Register are the valid commands that may be issued. If the system issues an Program Suspend command after the program operation has already begun, the device will not enter Program-Suspended Read mode until T_{psl} period has elapsed. The system can determine if the device has entered the Program-Suspended Read mode through Q6 and RY/BY# of Status Register or Extended Status Register.

After the device has entered Program-Suspended mode, the system can read any sector(s) except those being programmed by the suspended program operation. Reading the sector being program suspended is invalid. Whenever a suspend command is issued, user must issue a resume command and check Q6 toggle bit status, before issue another program command. The system can use the status register bits shown in the following table to determine the current state of the device, see the STATUS REGISTER for the details.

When the device has Program/Eraser suspended, user can execute read array, auto-select, read CFI, read security sector.

9-9. PROGRAM RESUME

The Program Resume command is valid only when the device is in Program-Suspended mode. After program resumes, the user can issue another Program Suspend command, but there should be a T_{prs} interval between Program Resume and the next Program Suspend command.

Figure 5. PROGRAM/ERASE SUSPEND/RESUME ALGORITHM FLOWCHART

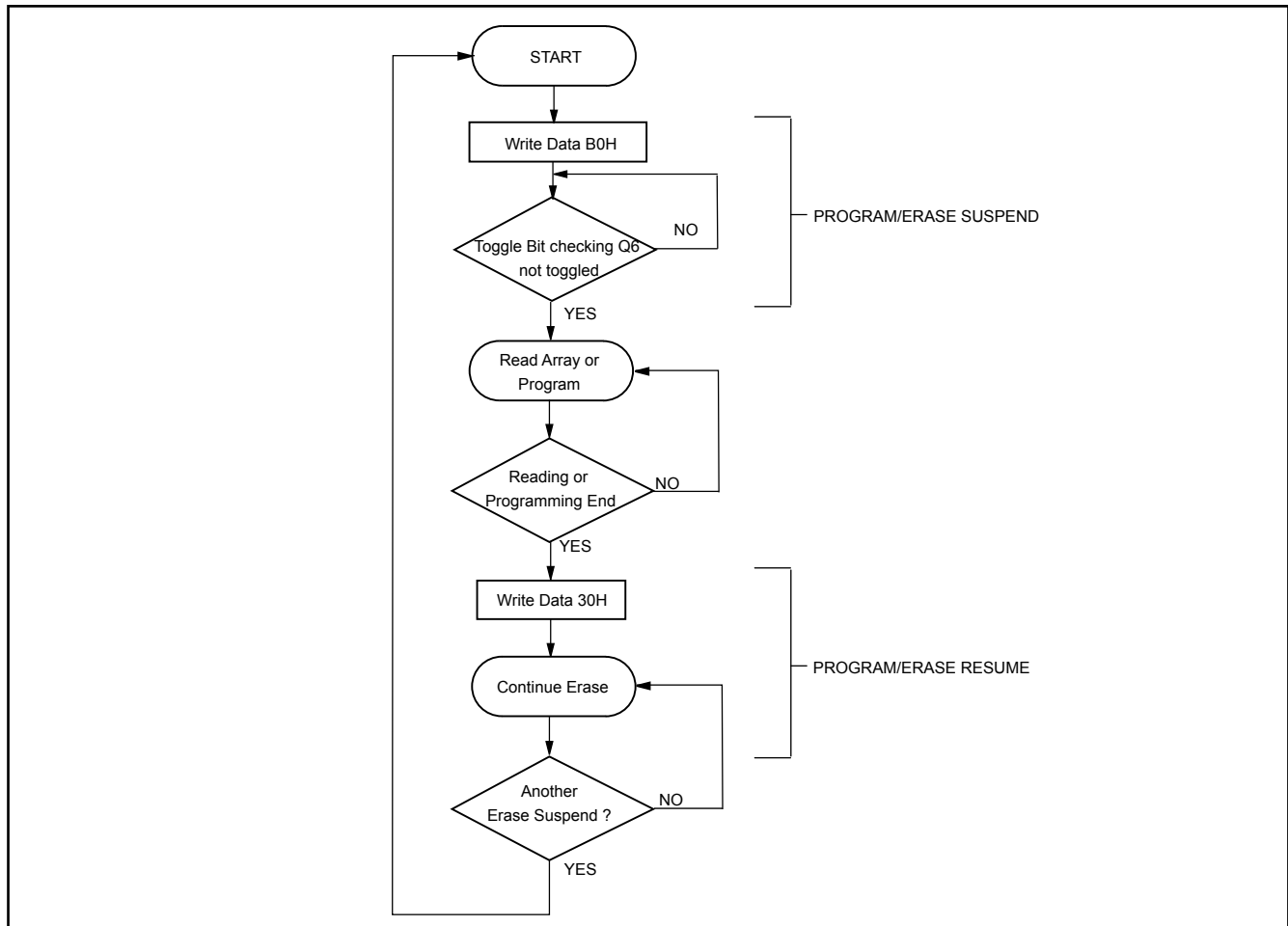

The system can use the status register bits shown in the following table to determine the current state of the device, see the STATUS REGISTER for the details.

When the device has suspended erasing, user can execute the command sets except sector erase and chip erase, such as Automatic select, program, CFI query and erase resume.

9-10. BLANK CHECK

Blank Check command can check if the erase operation works correctly in the selected sector. During the Blank Check, array read operation will return the contents of status register.

Write data 33h to address 555h into the sector to start the Blank Check.

In the following operations, Blank Check may not be written successfully:

1. program
2. erase
3. suspend

Device Ready (bit 7) of Extended Status Register or Status Register can display if the Blank Check is in progress or not.

Erase status (bit 5) of the Extended Status Register or Status Register can display the blank check result.

9-11. BUFFER WRITE ABORT

Status register Q1 is the indicator of Buffer Write Abort. When Q1=1, the device will abort from buffer write and go back to read, see WRITE BUFFER PROGRAMMING OPERATION for the details.

9-12. PROGRAM/ERASE STATUS CHECKING METHOD

When the device program/erase operation is in progress, either the "Polling Method", "Toggle Bit Method" or Extended Status Register" may be used to monitor the operation:

9-12-1. Polling Method:

The polling method checks Q7 (data complement bit) and Q5 (time out bit) values during the operation. After the operation has finished, Q7 will output true data. See the following figures for the word program/erase and write buffer program flowchart respectively.

Figure 6. STATUS POLLING FOR WORD PROGRAM/ERASE

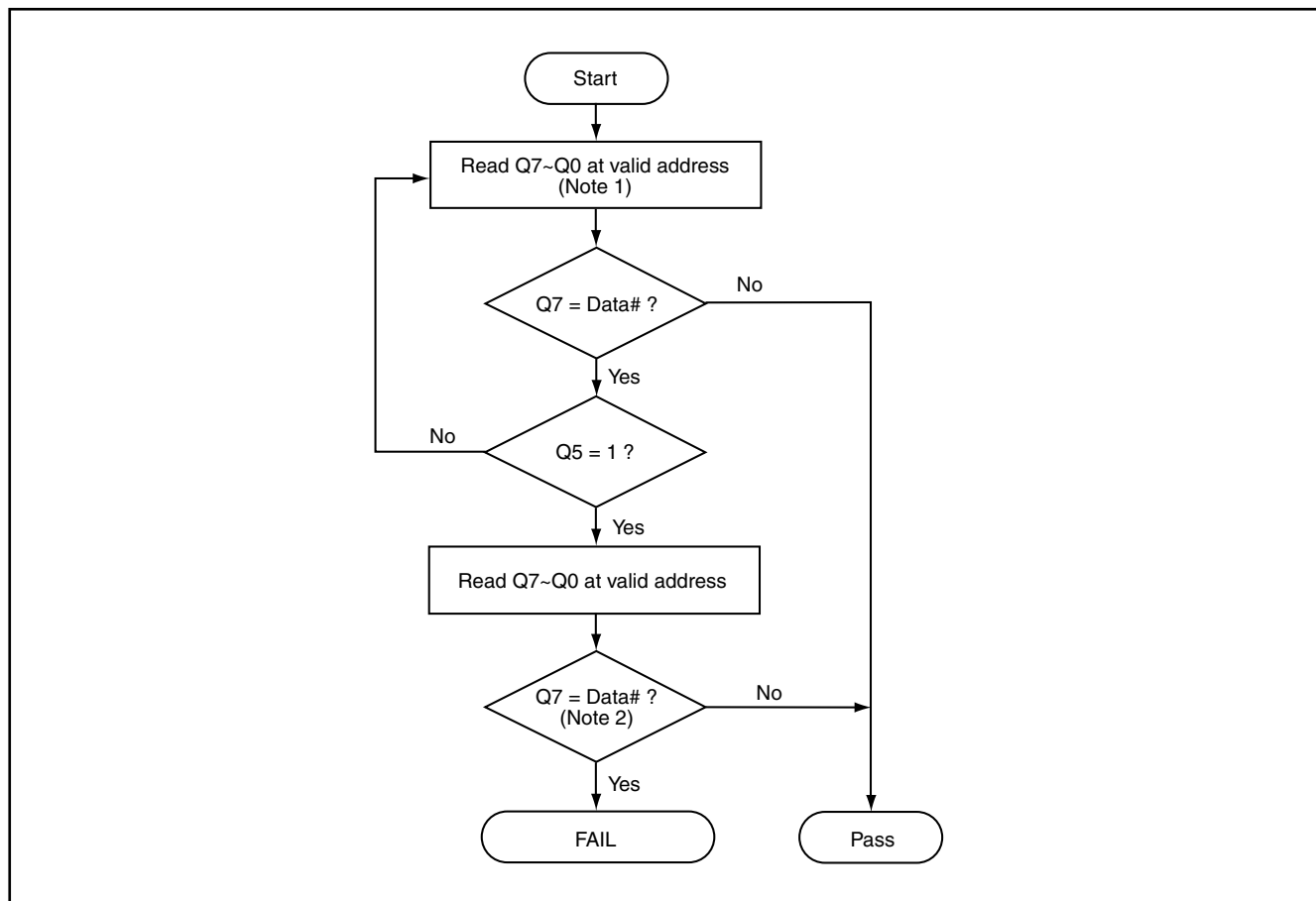

Notes:

1. For program, valid address means program address.
For erasing, valid address means erase sectors address.
2. Q7 should be rechecked even Q5="1" because Q7 may change simultaneously with Q5.

Figure 7. STATUS POLLING FOR WRITE BUFFER PROGRAM

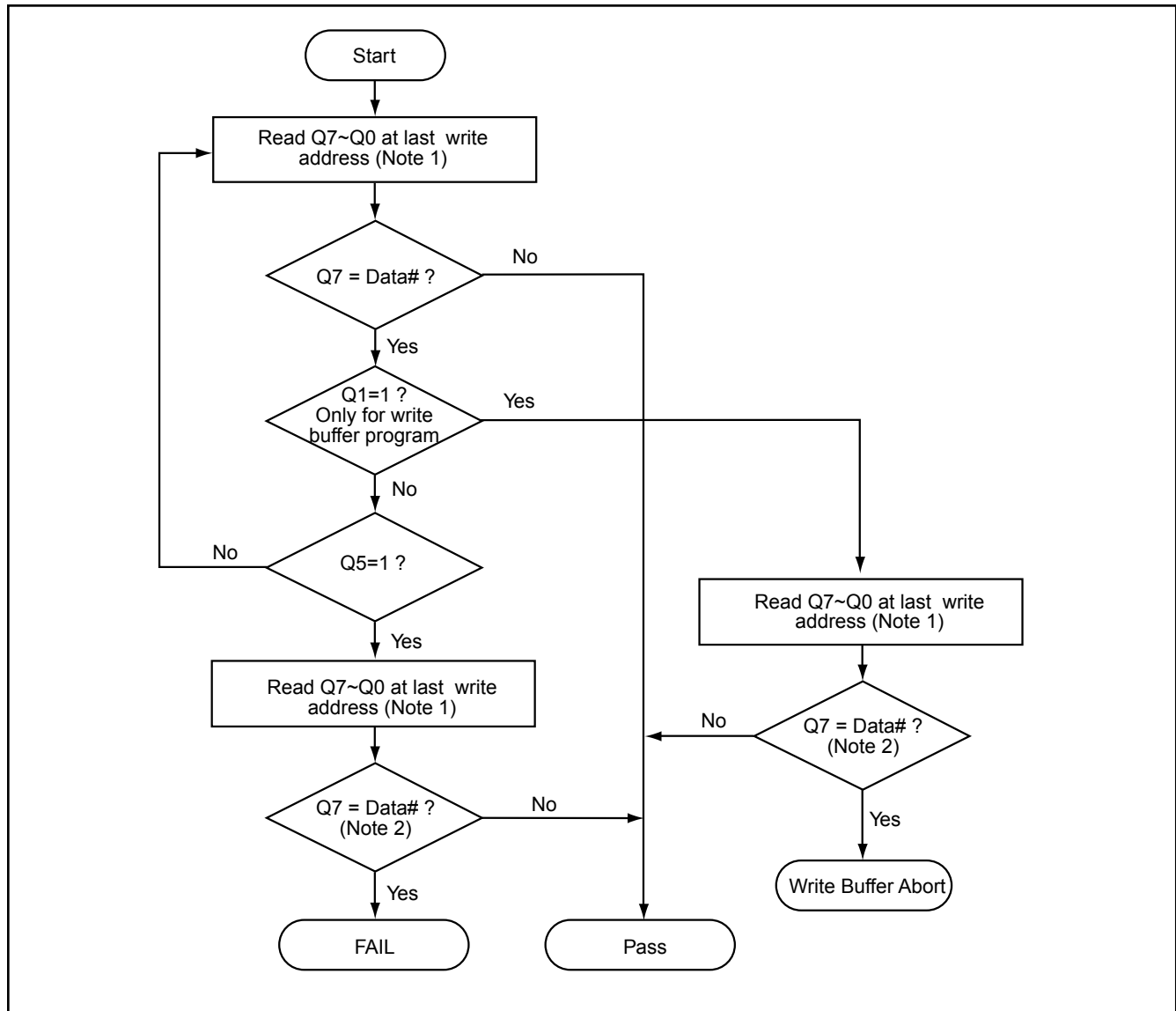

Notes:

1. For write to buffer programming, valid address means last write address.
2. Q7 should be rechecked even Q5="1" because Q7 may change simultaneously with Q5.

9-12-2. Toggle Bit Method:

The toggle bit method checks Q6 (toggle bit) value during the operation. After the operation has finished, Q6 will stop toggling. Please refer to the following figure for the toggle bit flowchart.

Figure 8. TOGGLE BIT ALGORITHM

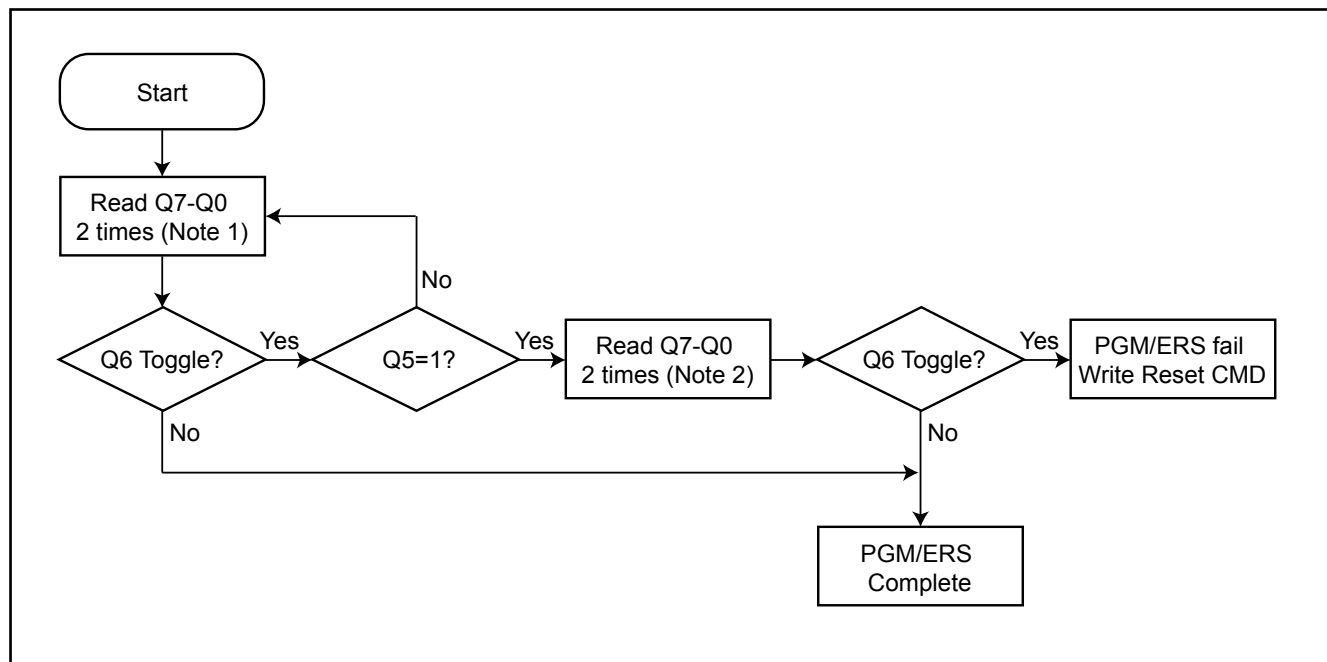

Notes:

1. Repeat Q7~Q0 read command 2 times to verify toggling status.
2. Q6 may stop toggling when Q5 switches to "1", need to verify toggling status once again.

9-12-3. Extended Status Register

Extended Status Register is a 16-bits register, which contains the program and erase status. These bits indicate whether the specific operations has completed successfully through the following bits:

- Erase Status (bit 5),
- Program Status (bit 4),
- Write Buffer Abort Status (bit 3),
- Sector Locked Status (bit 1)

Extended Status Register can also refer to whether the current status is in process, suspended, or completed through:

- Device Ready (bit 7),
- Erase Suspended Status (bit 6)
- Program Suspended Status (bit 2)

Bits 15:8 and bits 0 are reserved and must be regarded as don't care from any software reading status. Please refer to Extended Status Register Table for further information.

Table 4. EXTENDED STATUS REGISTER

Bit #	15:8	7	6	5	4	3	2	1	0
Description	Reserved	DRB (Device Ready)	ESSB (Erase Suspend Status)	ESB (Erase Status)	PSB (Program Status)	WBASB (Write Buffer Abort Status)	PSSB (Program Suspend Status)	SLSB (Sector Lock Status)	Reserved
Reset Status	X	1	0	0	0	0	0	0	X
Status Description	X	1=Ready, 0=Busy	0=No Erase in Suspension 1=Erase in Suspension	0=Erase successful 1=Erase fail	0=Program successful 1=Program fail	0=Program not aborted 1=Program aborted during Write to Buffer command	0=No Program in suspension 1=Program in suspension	0=Sector not locked during operation 1=Sector locked error	X

Notes:

1. While any operation is in progress, Bit 7=0 (busy). Bits 6 thru 1 are invalid while bit 7 = 0
2. User must read status continuously until DRB (Device Ready) becomes ready (=1) before issuing the Erase Suspend or Program Suspend Command.
3. Erase Resume Command will clear ESSB (Erase Suspend Status) to 0. Program Resume Command will clear PSSB (Program Suspend Status) to 0.
4. Program on erase suspended sector will result in Program fail (PSB [Program Status]=1).
5. SLSB (Sector Lock Status) represents the status of program or erase operation. While SLSB=1, it indicates that a program or erase operation has failed since the sector was locked.

The Status information could be retrieved by performing the Read Extended Status Register command and a following read operation. When Read Extended Status Register Command has been written, the device captures the status information on the rising edge of WE#, and then places the status information in the device address locations.

The Clear Extended Status Register Command or reset command will clear these results related Extended Status Register bits (bit 5, bit 4, bit 3 and bit 1) to 0 without affecting the current state bits (bit 7, bit 6, and bit 2).

It's recommended to use Extended Status Register instead of Data Polling Status feature to determine device status. See the following figure for the Write Buffer Program and sector erase flowchart.

Figure 9. EXTENDED STATUS REGISTER FOR WRITE BUFFER PROGRAM

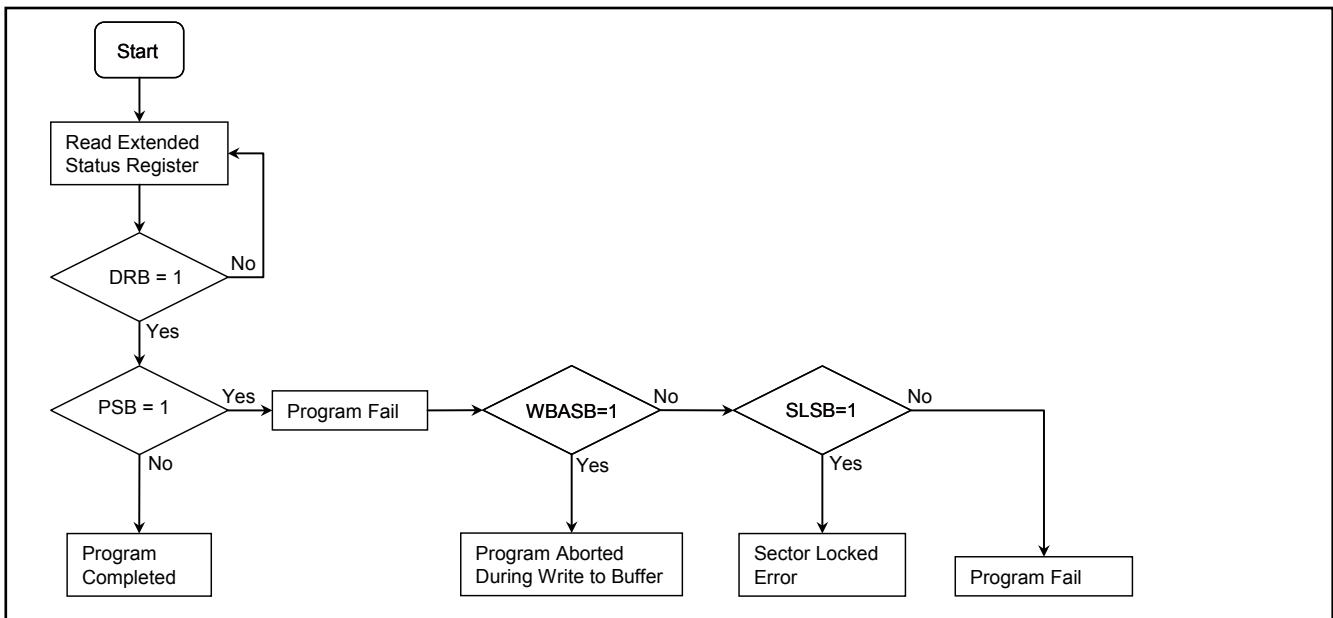
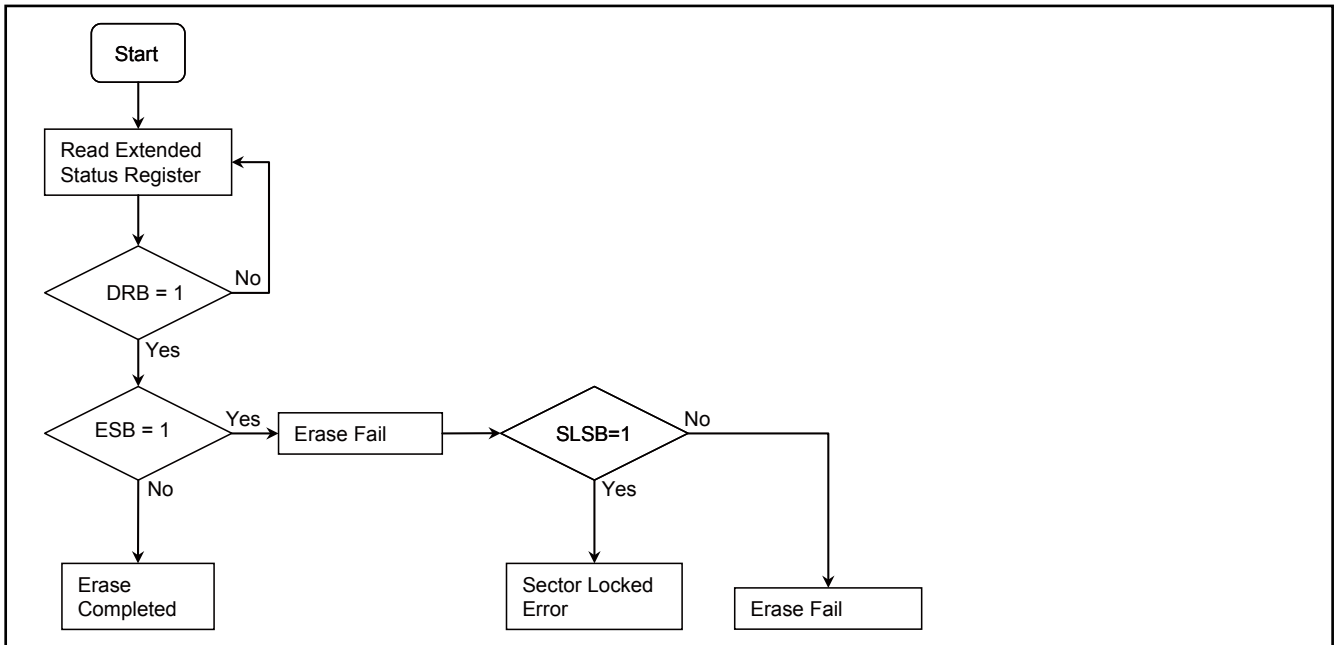

Figure 10. EXTENDED STATUS REGISTER FOR SECTOR ERASE



9-13. STATUS REGISTER

The host system can use the status register bits shown in the following table to determine the current state of the device.

Table 5. STATUS REGISTER

Status		Q7	Q6	Q5	Q3	Q2	Q1	RY/BY#
Automatic programming	In progress	Q7#	Toggle	0	N/A	N/A	0	0
	Exceed time limit	Q7#	Toggle	1	N/A	N/A	N/A	0
Sector erase	In progress	0	Toggle	0	1	Toggle	N/A	0
	Exceed time limit	0	Toggle	1	1	Toggle	N/A	0
Chip erase	In progress	0	Toggle	0	N/A	Toggle	N/A	0
	Exceed time limit	0	Toggle	1	N/A	Toggle	N/A	0
Program suspend read	program suspended sector	Invalid						1
	non-program suspended sector	Data						1
Erase suspend read	erase suspended sector	1	No toggle	0	N/A	Toggle	N/A	1
	non-erase suspended sector	Data						1
Erase suspend program in non-erase suspended sector		Q7#	Toggle	0	N/A	N/A	N/A	0
Buffer Write	Busy	Q7#	Toggle	0	N/A	N/A	0	0
	Abort	Q7#	Toggle	0	N/A	N/A	1	0
	Exceed time limit	Q7#	Toggle	1	N/A	N/A	0	0

Notes:

1. RY/BY# is open drain output pin and should be connected to VCC through a high value pull-up resistor.
2. Erase Suspend and Read Extended Status Register are the valid commands that may be issued once the sector erase operation is in progress.
3. RY/BY# is open drain output pin and should be connected to VCC through a high value pull-up resistor.
4. When an attempt is made to erase only protected sector (s), the erase operation will abort thus preventing any data changes in the protected sector (s). Q7 will output "0" and Q6 will toggle briefly (100us or less) before aborting and returning the device to Read mode.
5. Q2 is a localized indicator showing a specified sector is undergoing erase operation or not. Q2 toggles when user reads at addresses where the sectors are actively being erased (in erase mode) or to be erased (in erase suspend mode).

9-14. AUTOMATIC SELECT OPERATIONS

When the device is in Read mode, Program Suspended mode, Erase-Suspended Read mode, or CFI mode, the user can issue the Automatic Select command shown in "Table 9. COMMAND DEFINITIONS" (two unlock cycles followed by the Automatic Select command 90h) to enter Automatic Select mode. After entering Automatic Select mode, the user can query the Manufacturer ID, Device ID, Security Sector locked status, or Sector protected status multiple times without issuing a new Automatic Select command.

While In Automatic Select mode, issuing a Reset command (F0h) will return the device to Read mode (or Ease-Suspended Read mode if Erase-Suspend was active) or Program Suspended Read mode if Program Suspend was active.

9-14-1. AUTOMATIC SELECT COMMAND SEQUENCE

The automatic select mode has four command cycles. The first two are unlock cycles, and followed by a specific command. The fourth cycle is a normal read cycle, and user can read at any address any number of times without entering another command sequence. The Reset command is necessary to exit the Automatic Select mode and back to read array. The following table shows the identification code with corresponding address.

Table 6. AUTOMATIC SELECT ID VALUE

	Address (h)		Data (h)	
	Word Mode	Byte Mode		
Manufacturer ID	00	00	C2	
Device ID	01/0E/0F	02/1C/1E		Word Mode
				Byte Mode
			512Mb	227E/2223/2201
			1Gb	227E/2228/2201
Sector Protect Verify	(Sector address) 02	(Sector address) 04	0: Sector Unprotected 1: Sector Protected	
Security Sector Status	03	06	Bit15-Bit8 = 1 (Reserved) Bit7: Factory Locked Area 1 = Locked, 0 = Unlocked Bit6: Customer Locked Area 1 = Locked, 0 = Unlocked Bit5 = 1 (Reserved) Bit4: WP# Protects 0 = lowest address Sector protected 1 = highest address Sector protected Bit3-Bit0 = 1 (Reserved)	
Command Set Support	0C	18	Bit15-Bit4 = 0 (Reserved) Bit3-Bit2: Command Set 11/10=reserved, 01= Short version, 00= Full version Bit1: Data# Polling 1=support, 0 =not support Bit0: Extended Status Register 1=support, 0=not support	

Notes:

Page read feature is not support, while read address 02h or read between any other ID addresses and 02h. After entering automatic select mode, no other commands are allowed except the reset command.

9-14-2. AUTOMATIC SELECT HIGH VOLTAGE OPERATION

Another way to enter Automatic Select mode is to use high voltage operations as following Table. After the high voltage (V_{hv}) is removed from the A9 pin, the device will automatically return to Read mode or Erase-Suspended Read mode.

Table 7. AUTOMATIC SELECT HIGH VOLTAGE OPERATION

Item	Control Input			AM to A12	A11 to A10	A9	A8 to A7	A6	A5 to A4	A3 to A2	A1	A0	Q7 ~ Q0	Q15 ~ Q8
	CE#	WE#	OE#											
Sector Protect Verify	L	H	L	SA	X	V _{hv}	X	L	X	L	H	L	01h or 00h (Note 1)	X
Security Sector Status	L	H	L	X	X	V _{hv}	X	L	X	L	H	H	(Note 2)	X
Read Manufacturer ID	L	H	L	X	X	V _{hv}	X	L	X	L	L	L	C2H	X
Read Device ID -- 512Mb/1Gb														
Cycle 1	L	H	L	X	X	V _{hv}	X	L	X	L	L	H	7EH	22H(Word), XXH(Byte)
Cycle 2	L	H	L	X	X	V _{hv}	X	L	X	H	H	L	23H 512Mb 28H 1Gb	22H(Word), XXH(Byte)
Cycle 3	L	H	L	X	X	V _{hv}	X	L	X	H	H	H	01H	22H(Word), XXH(Byte)

Notes:

1. Sector unprotected code: 00h. Sector protected code:01h.
2. The factory lock status should be presented on data bit Q7, and customer lock status should be presented on data bit Q6, refer Table 6 for detail value.
3. AM: MSB of address.
4. Page read feature is not supported in automatic select high voltage operation.

READ MANUFACTURER ID OR DEVICE ID

The Manufacturer ID (identification) is a unique hexadecimal number assigned to each manufacturer by the JEDEC committee. Each company has its own manufacturer ID, which is different from the ID of all other companies. The number assigned to Macronix is C2h.

To determine the Manufacturer ID Code, the system performs a READ OPERATION with A9 raised to V_{hv} and address pins A6, A3, A2, A1, & A0 held LOW. The Macronix ID code of C2h should be presented on data bits Q7 to Q0.

SECTOR LOCK STATUS VERIFICATION

To determine the protected state of any sector using bus operations, the system performs a READ OPERATION with A9 raised to V_h, the sector address applied to the highest address pins A24/A25(512Mb/1Gb), address pins A6, A3, A2 & A0 held LOW, and address pin A1 held HIGH. If data bit Q0 is LOW, the sector is not protected, and if Q0 is HIGH, the sector is protected.

READ SECURITY SECTOR STATUS

To determine if the Security Sector has been locked at the factory, the system performs a READ OPERATION with A9 raised to V_h, address pin A6, A3 & A2 held LOW, and address pins A1 & A0 held HIGH. The factory lock status should be presented on data bit Q7, and customer lock status should be presented on data bit Q6, refer Table 4 for detail value.

9-15. COMMON FLASH MEMORY INTERFACE (CFI) QUERY COMMAND

The device features CFI mode. Host system can retrieve the operating characteristics, structure and vendor-specified information such as identifying information, memory size, byte/word configuration, operating voltages and timing information of this device by CFI mode. If the system writes the CFI Query command "98h", to address "55h"/"AAh" (depending on Word/Byte mode), the device will enter the CFI Query Mode, any time the device is ready to read array data. The system can read CFI information at the addresses given in [Table 10](#) ~ [Table 13](#).

Once user enters CFI query mode, user can issue reset command to exit CFI mode and return to read array mode.

9-16. RESET

In the following situations, executing reset command will reset device back to Read mode:

- Among erase command sequence (before the full command set is completed)
- Sector erase time-out period
- Erase fail (while Q5 is high)
- Among program command sequence (before the full command set is completed, erase-suspended program included)
- Program fail (while Q5 is high, and erase-suspended program fail is included)
- Auto-select mode
- CFI mode

While device is at the status of program fail or erase fail (Q5 is high), user must issue reset command to reset device back to read array mode. While the device is in Auto-Select mode, CFI mode, user must issue reset command to reset device back to read array mode.

When the device is in the progress of programming (not program fail) or erasing (not erase fail), device will ignore reset command.

9-17. ADVANCED SECTOR PROTECTION/UNPROTECTION

There are two ways to implement software Advanced Sector Protection on this device: Password method or Solid methods. Through these two protection methods, user can disable or enable the programming or erasing operation to any individual sector or the whole chip. The figure below helps to describe an overview of these methods.

The device is default to the Solid mode. All sectors are default as unprotected when shipped from factory. The detailed algorithm of advance sector protection is shown as follows:

Figure 11. ADVANCE SECTOR PROTECTION/UNPROTECTION SPB PROGRAM ALGORITHM

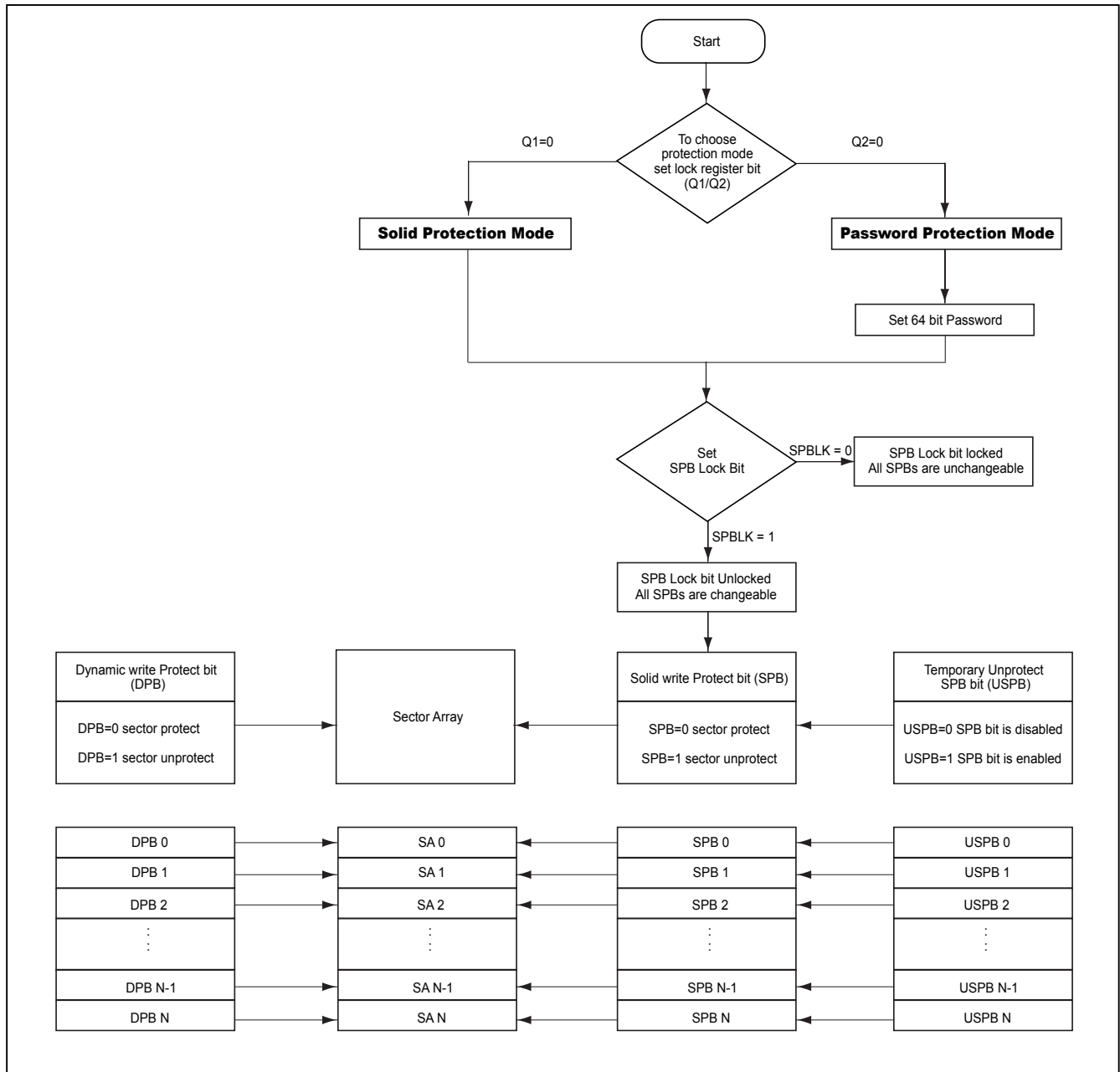

9-17-1. Lock Register

User can choose the sector protecting method via setting Lock Register bits as Q1 and Q2. Lock Register is a 16-bit one-time programmable register. Once programming either Q1 and Q2, they will be locked in that mode and the others will be disabled permanently. Q1 and Q2 can not be programmed at the same time, otherwise the device will abort the operation.

If users select Password Protection mode, the password setting is required. Users can set password by issuing password program command.

Lock Register bits

Q15~Q7, Q5~Q3	Q6	Q2	Q1	Q0
Reserved	Security Sector Customer Lock bit	Password Protection Mode Lock Bit	Solid Protection Mode Lock Bit	Security Sector Factory Lock bit

Please refer to the command for Lock Register command set to read and program the Lock register.

Figure 12. LOCK REGISTER PROGRAM ALGORITHM

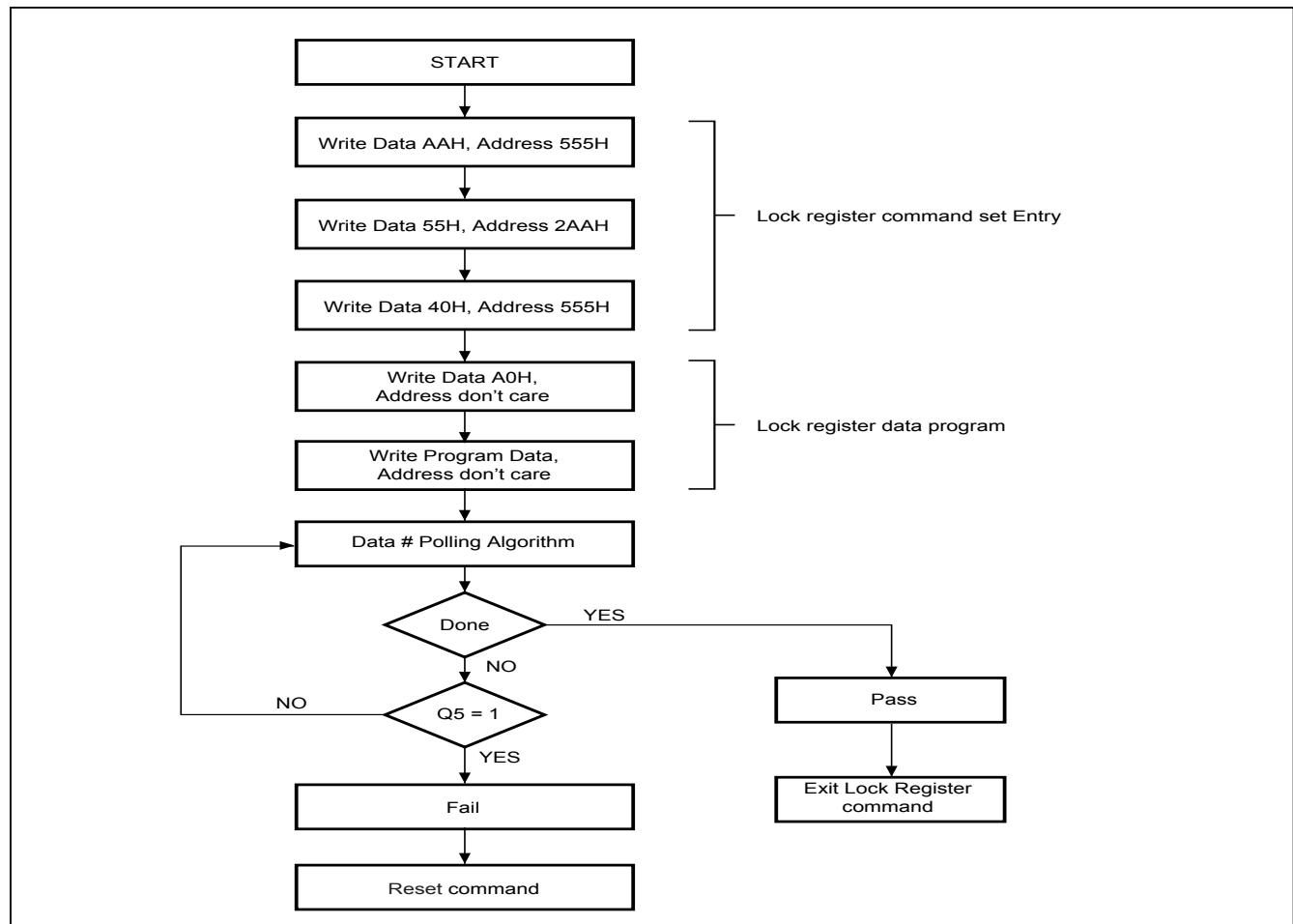

9-17-2. Solid Protection Mode

Solid write Protection Bits (SPB)

The Solid write Protection bits (SPB) are nonvolatile bit with the same endurance as the Flash memory. Each SPB is assigned to each sector individually. The SPB is preprogrammed, and verified prior to erasure are managed by the device, so system monitoring is not necessary.

When SPB is set to "0", the associated sector may be protected, preventing any program or erase operation on this sector. Whether the sector is protected depends also upon the value of the USPB, as described elsewhere. The SPB bits are set individually by SPB program command. However, it cannot be cleared individually. Issuing the All SPB Erase command will erase all SPB in the same time. During SPB programming period, the read and write operations are disabled for normal sector until exiting this mode.

To unprotect a protected sector, the SPB lock bit must be cleared first by using a hardware reset or a power-up cycle. After the SPB lock bit is cleared, the SPB status can be changed to the desired settings. To lock the Solid Protection Bits after the modification has finished, the SPB Lock Bit must be set once again.

To verify the state of the SPB for a given sector, issuing a SPB Status Read Command to the device is required. Refer to the flow chart for details of SPB Program in ["Figure 13. SPB PROGRAM ALGORITHM"](#).

Dynamic Protection Bits (DPB)

The Dynamic Protection features a volatile type protection to each individual sector. It can protect sectors from being unintentionally changed, and is easy to disable.

All Dynamic write Protection bit (DPB) can be modified individually. DPBs protect the unprotected sectors with their SPBs cleared. To modify the DPB status by issuing the DPB Set (to "0") or DPB Clear (to "1") commands, and place each sector in the protected or unprotected state separately. After the DPB Clear (to "1") command is issued, the sector may be modified depending on the SPB state of that sector.

The DPBs are default to be cleared (to "1") when first shipped from factory.

Temporary Un-protect Solid write Protect Bits (USPB)

Temporary Un-protect Solid write Protect Bits are volatile. They are unique for each sector and can be individually modified. Software can temporarily unprotect write protect sectors despite of SPB's property when DPBs are cleared. While the USPB is set (to "0"), the corresponding sector's SPB property is masked.

Notes:

1. Upon power up, the USPBs are cleared (all "1"). The USPBs can be set (to "0") or cleared (to "1") as often as needed. The hardware reset will reset USPB/DPB to their default values.
2. To change the protected sector status of solid write protect bit, users don't need to clear all SPBs. The users can just implement software to set corresponding USPB to "0", in which the corresponding DPB status is cleared too. Consequently, the original solid write protect status of protected sectors can be temporarily changed.

Figure 13. SPB PROGRAM ALGORITHM

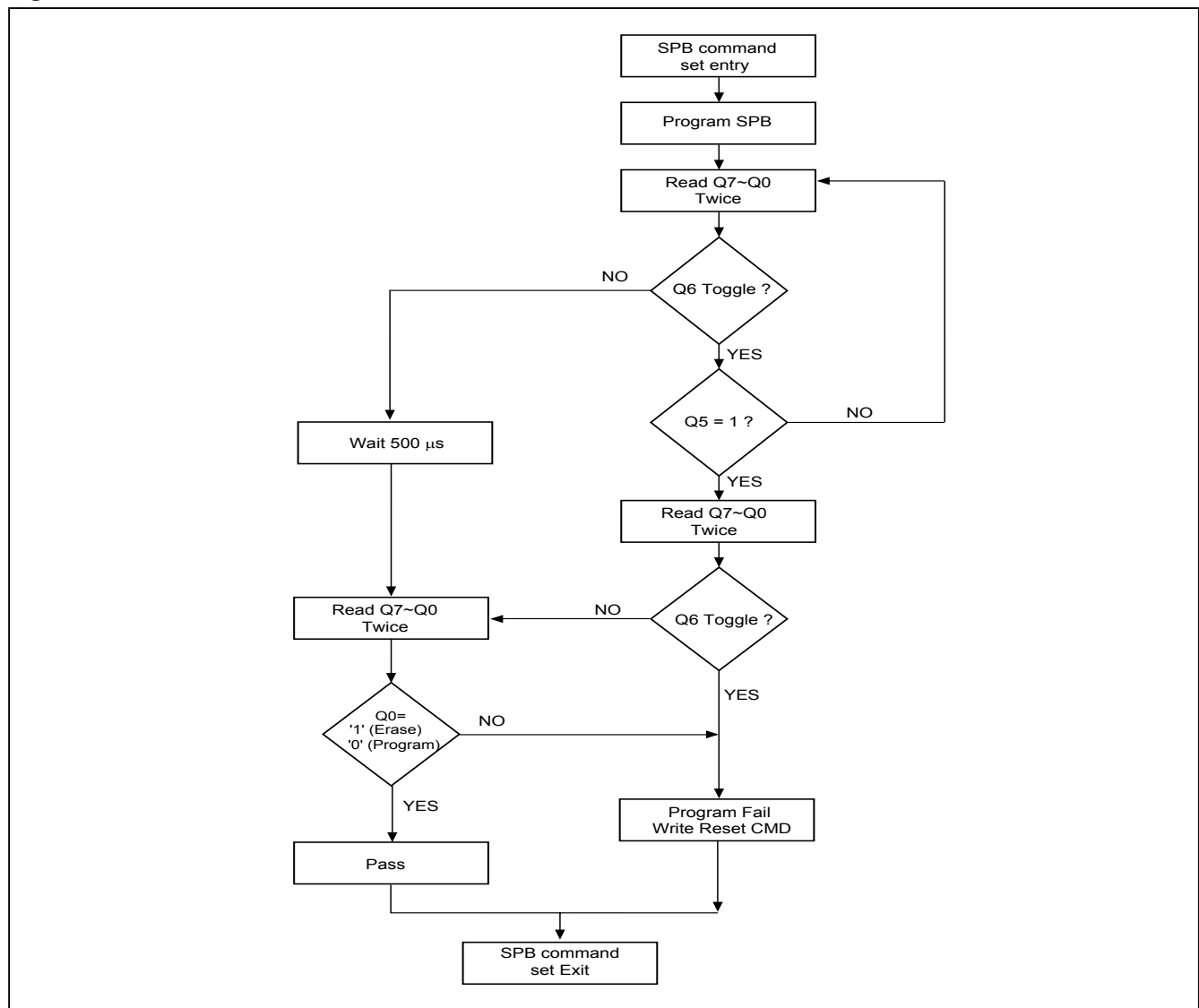

Note: SPB program/erase status polling flowchart: check Q6 toggle, when Q6 stop toggle, the read status is 00H /01H (00H for program/ 01H for erase), otherwise, the status is "fail" and "exit".

9-17-3. Solid Protection Bit Lock Bit

The Solid Protection Bit Lock Bit (SPBLK) is assigned to control all SPB status. It is an unique and volatile. When SPBLK=0 (set), all SPBs are locked and can not be changed. When SPBLK=1 (cleared), all SPBs are allowed to be changed.

There is no software command sequence requested to unlock this bit, unless the device is in the password protection mode. To clear the SPB Lock Bit, just execute a hardware reset or a power-up cycle. In order to prevent modification, the SPB Lock Bit must be set (SPBLK=0) after all SPBs are set to desired status.

9-17-4. Password Protection Method

The security level of Password Protection Method is higher than the Solid protection mode. The 64 bit password is requested before modifying SPB lock bit status. When device is under password protection mode, the SPB lock bit is set as "0", after a power-up cycle or Reset Command.

A correct password is required for password Unlock command to unlock the SPB lock bit. Await 100us is necessary to unlock the device after a valid password is given. After that, the SPB bits are allowed to be changed. The Password Unlock command is issued slower than 100 μ s every time, to prevent hacker from trying all the 64-bit password combinations.

There are a few steps to start password protection mode:

- (1). Set a 64-bit password for verification before entering the password protection mode. This verification is only allowed in password programming.
- (2). Set the Password Protection Mode Lock Bit to "0" to activate the password protection mode.

Once the password protection mode lock bit is programmed, the programmed Q2 bit can not be erased any more and the device will remain permanently in password protection mode. The previous set 64-bit password can not be retrieved or programmed. All the commands to the password-protected address will also be disabled.

All the combinations of the 64-bit password can be used as a password, and programming the password does not require special address. The password is defaulted to be all "1" when shipped from the factory. Under password program command, only "0" can be programmed. In order to prevent access, the Password Mode Locking Bit must be set after the Password is programmed and verified. To set the Password Mode Lock Bit will prevent this 64-bits password to be read on the data bus. Any modification is impossible then, and the password can not be checked anymore after the Password Mode Lock Bit is set.

Table 8. SECTOR PROTECTION STATUS TABLE

Protection Bit Status			Sector Status
DPB	SPB	USPB	
clear (1)	clear (1)	clear (1)	Unprotected
clear (1)	clear (1)	set (0)	Unprotected
clear (1)	set (0)	clear (1)	Protected
clear (1)	set (0)	set (0)	Unprotected
set (0)	clear (1)	clear (1)	Protected
set (0)	clear (1)	set (0)	Protected
set (0)	set (0)	clear (1)	Protected
set (0)	set (0)	set (0)	Protected

Notes: If SPBLK is set, SPB will be unchangeable.
If SPBLK is cleared, SPB will be changeable.

9-18. SECURITY SECTOR FLASH MEMORY REGION

The Security Sector region is an extra OTP memory space of 512 word in length. The security sector can be locked upon shipping from factory, or it can be locked by customer after shipping. Customer can issue Security Sector Status and/or Security Sector Protect Verify to query the lock status of the device.

The device will have a 512 word (1024 byte) in the security region 00000h to 003FEh in byte mode or 00000h to 001FFh in word mode.

9-19. FACTORY LOCKED: CAN BE PROGRAMMED AND PROTECTED AT THE FACTORY

In factory locked area, security sector region is protected when shipped from factory and permanently locked. The Lock Register "Security Sector Factory Lock bit" DQ0 is set to "0".

Security Sector Address Range	OTP Area Definition	OTP Length
000000h-0000FFh	Factory Locked Area	256 word
000100h-0001FFh	Customer Locked Area	256 word

9-20. CUSTOMER LOCKED: NOT PROGRAMMED AND NOT PROTECTED AT FACTORY

In customer Locked area, security sector region is unprotected when shipped from factory. The Lock Register "Security Sector Customer Lock bit" DQ6 is set to "1" by default. Note that once the security sector is protected, there is no way to unprotect the security sector and the content of it can no longer be altered.

After the security sector is locked and verified, system must write Exit Security Sector Region, go through a power cycle, or issue a hardware reset to return the device to read normal array mode.

10. COMMAND REFERENCE SUMMARY

10-1. COMMAND DEFINITIONS

Table 9. COMMAND DEFINITIONS

Command		Read Mode	Reset Mode	Enter Automatic Select Mode		Enter CFI Mode		Security Sector Region		Exit Security Sector		Read Extended Status Register		Clear Extended Status Register	
				Word	Byte	Word	Byte	Word	Byte	Word	Byte	Word	Byte	Word	Byte
1st Bus Cycle	Addr	Addr	xxx	555	AAA	(SA) 55	(SA) AA	555	AAA	555	AAA	555	AAA	555	AAA
	Data	Data	F0	AA	AA	98	98	AA	AA	AA	AA	70	70	71	71
2nd Bus Cycle	Addr			2AA	555			2AA	555	2AA	555	xxx	xxx		
	Data			55	55			55	55	55	55	Data	Data		
3rd Bus Cycle	Addr			(SA) 555	(SA) AAA			(SA) 555	(SA) AAA	555	AAA				
	Data			90	90			88	88	90	90				
4th Bus Cycle	Addr									XXX	XXX				
	Data									00	00				
5th Bus Cycle	Addr														
	Data														
6th Bus Cycle	Addr														
	Data														

Command		Program		Write to Buffer Program		Write to Buffer Program Abort Reset		Write to Buffer Program confirm	
		Word	Byte	Word	Byte	Word	Byte	Word	Byte
1st Bus Cycle	Addr	555	AAA	555	AAA	555	AAA	SA	SA
	Data	AA	AA	AA	AA	AA	AA	29	29
2nd Bus Cycle	Addr	2AA	555	2AA	555	2AA	555		
	Data	55	55	55	55	55	55		
3rd Bus Cycle	Addr	555	AAA	SA	SA	555	AAA		
	Data	A0	A0	25	25	F0	F0		
4th Bus Cycle	Addr	Addr	Addr	SA	SA				
	Data	Data	Data	N-1	N-1				
5th Bus Cycle	Addr			WA	WA				
	Data			WD	WD				
6th Bus Cycle	Addr			WBL	WBL				
	Data			WD	WD				

WA= Write Address

WD= Write Data

SA= Sector Address

N-1= Word Count

WBL= Write Buffer Location

PWD= Password

PWDn=Password word 0, word 1, word n

ID1/ID2/ID3: Refer to ["Table 7. AUTOMATIC SELECT HIGH VOLTAGE OPERATION"](#) for detailed ID.

Command		Blank Check		Chip Erase		Sector Erase		Program/ Erase Suspend		Program/ Erase Resume		Program Suspend Specific Method		Program Resume Specific Method	
		Word	Byte	Word	Byte	Word	Byte	Word	Byte	Word	Byte	Word	Byte	Word	Byte
1st Bus Cycle	Addr	(SA) 555	(SA) AAA	555	AAA	555	AAA	xxx	xxx	xxx	xxx	xxx	xxx	xxx	xxx
	Data	33	33	AA	AA	AA	AA	B0	B0	30	30	51	51	50	50
2nd Bus Cycle	Addr			2AA	555	2AA	555								
	Data			55	55	55	55								
3rd Bus Cycle	Addr			555	AAA	555	AAA								
	Data			80	80	80	80								
4th Bus Cycle	Addr			555	AAA	555	AAA								
	Data			AA	AA	AA	AA								
5th Bus Cycle	Addr			2AA	555	2AA	555								
	Data			55	55	55	55								
6th Bus Cycle	Addr			555	AAA	Sector	Sector								
	Data			10	10	30	30								

Command		Deep Power Down				Password Protection									
		Enter		Exit		Password Command Set Entry		Password Program		Password Read		Password Unlock		Password Command Set Exit	
		Word	Byte	Word	Byte	Word	Byte	Word	Byte	Word	Byte	Word	Byte	Word	Byte
1st Bus Cycle	Addr	555	AAA	XXX	XXX	555	AAA	XXX	XXX	00	00	00	00	XXX	XXX
	Data	AA	AA	AB	AB	AA	AA	A0	A0	PWD0	PWD0	25	25	90	90
2nd Bus Cycle	Addr	2AA	555			2AA	555	PWA	PWA	01	01	00	00	XXX	XXX
	Data	55	55			55	55	PWD	PWD	PWD1	PWD1	03	03	00	00
3rd Bus Cycle	Addr	XXX	XXX			555	AAA			02	02	00	00		
	Data	B9	B9			60	60			PWD2	PWD2	PWD0	PWD0		
4th Bus Cycle	Addr									03	03	01	01		
	Data									PWD3	PWD3	PWD1	PWD1		
5th Bus Cycle	Addr									04	02	02			
	Data									PWD4	PWD2	PWD2			
6th Bus Cycle	Addr									05	03	03			
	Data									PWD5	PWD3	PWD3			
7th Bus Cycle	Addr									06	00	04			
	Data									PWD6	29	PWD4			
8th Bus Cycle	Addr									07		05			
	Data									PWD7		PWD5			
9th Bus Cycle	Addr											06			
	Data											PWD6			
10th Bus Cycle	Addr											07			
	Data											PWD7			
11th Bus Cycle	Addr											00			
	Data											29			

Command		Lock Register								Global Non-Volatile							
		Lock register Command Set Entry		Program		Read		Lock register Command Set Exit		SPB Command Set Entry		SPB Program		All SPB Erase		SPB Status Read	
		Word	Byte	Word	Byte	Word	Byte	Word	Byte	Word	Byte	Word	Byte	Word	Byte	Word	Byte
1st Bus Cycle	Addr	555	AAA	XXX	XXX	XXX	XXX	XXX	XXX	555	AAA	XXX	XXX	XXX	XXX	SA	SA
	Data	AA	AA	A0	A0	DATA	DATA	90	90	AA	AA	A0	A0	80	80	00/01	00/01
2nd Bus Cycle	Addr	2AA	555	XXX	XXX			XXX	XXX	2AA	555	SA	SA	00	00		
	Data	55	55	Data	Data			00	00	55	55	00	00	30	30		
3rd Bus Cycle	Addr	555	AAA							555	AAA						
	Data	40	40							C0	C0						
4th Bus Cycle	Addr																
	Data																
5th Bus Cycle	Addr																
	Data																

Command		Global Non-Volatile		Global Volatile Freeze								Volatile					
		SPB Command Set Exit		SPB Lock Command Set Entry		SPB Lock Set		SPB Lock Status Read		SPB Lock Command Set Exit		DPB Command Set Entry		DPB Set		DPB Clear	
		Word	Byte	Word	Byte	Word	Byte	Word	Byte	Word	Byte	Word	Byte	Word	Byte	Word	Byte
1st Bus Cycle	Addr	XXX	XXX	555	AAA	XXX	XXX	XXX	XXX	XXX	XXX	555	AAA	XXX	XXX	XXX	XXX
	Data	90	90	AA	AA	A0	A0	00/01	00/01	90	90	AA	AA	A0	A0	A0	A0
2nd Bus Cycle	Addr	XXX	XXX	2AA	555	XXX	XXX			XXX	XXX	2AA	555	SA	SA	SA	SA
	Data	00	00	55	55	00	00			00	00	55	55	00	00	01	01
3rd Bus Cycle	Addr			555	AAA							555	AAA				
	Data			50	50							E0	E0				
4th Bus Cycle	Addr																
	Data																
5th Bus Cycle	Addr																
	Data																

Command		Volatile			
		DPB Status Read		DPB Command Set Exit	
		Word	Byte	Word	Byte
1st Bus Cycle	Addr	SA	SA	XXX	XXX
	Data	00/01	00/01	90	90
2nd Bus Cycle	Addr			XXX	XXX
	Data			00	00
3rd Bus Cycle	Addr				
	Data				
4th Bus Cycle	Addr				
	Data				
5th Bus Cycle	Addr				
	Data				

Notes:

- * It is not recommended to adopt any other code not in the command definition table which will potentially enter the hidden mode.
- * For the SPB Lock and DPB Status Read "00" means lock (protect), "01" means unlock (unprotect).

10-2. COMMON FLASH MEMORY INTERFACE (CFI) MODE

The host system can read CFI information at the addresses given in the following [Table 10~Table 13](#), the query data is always presented on the lowest order data outputs.

Table 10. CFI MODE: IDENTIFICATION DATA VALUES

(All values in these tables are in hexadecimal)

Description	Address (h) (Word Mode)	Address (h) (Byte Mode)	Data (h)
Query-unique ASCII string "QRY"	10	20	0051
	11	22	0052
	12	24	0059
Primary vendor command set and control interface ID code	13	26	0002
	14	28	0000
Address for primary algorithm extended query table	15	2A	0040
	16	2C	0000
Alternate vendor command set and control interface ID code	17	2E	0000
	18	30	0000
Address for alternate algorithm extended query table	19	32	0000
	1A	34	0000

Table 11. CFI MODE: SYSTEM INTERFACE DATA VALUES

Description	Address (h) (Word Mode)	Address (h) (Byte Mode)	Data (h)
Vcc supply minimum program/erase voltage	1B	36	0027
Vcc supply maximum program/erase voltage	1C	38	0036
VPP supply minimum program/erase voltage	1D	3A	0000
VPP supply maximum program/erase voltage	1E	3C	0000
Typical timeout per single word/byte write, 2 ⁿ us	1F	3E	0005
Typical timeout for maximum-size buffer write, 2 ⁿ us (00h, not support)	20	40	0009
Typical timeout per individual block erase, 2 ⁿ ms	21	42	0008
Typical timeout for full chip erase, 2 ⁿ ms (00h, not support)	22	44	512Mb 0011
			1Gb 0012
Maximum timeout for word/byte write, 2 ⁿ times typical	23	46	0003
Maximum timeout for buffer write, 2 ⁿ times typical	24	48	0002
Maximum timeout per individual block erase, 2 ⁿ times typical	25	4A	0003
Maximum timeout for chip erase, 2 ⁿ times typical (00h, not support)	26	4C	0001

Table 12. CFI MODE: DEVICE GEOMETRY DATA VALUES

Description	Address (h)	Address (h)	Data (h)	
	(Word Mode)	(Byte Mode)		
Device size = 2 ⁿ in number of bytes	27	4E	512Mb	001A
			1Gb	001B
Flash Device Interface Description 0 = x8-only, 1 = x16-only, 2 = x8/x16 capable	28	50	0002	
	29	52	0000	
Maximum number of bytes in buffer write = 2 ⁿ (00h, not support)	2A	54	0009	
	2B	56	0000	
Number of erase regions within device (01h:uniform, 02h:boot)	2C	58	0001	
	2D	5A	00FF	
Index for Erase Bank Area 1: [2E,2D] = # of same-size sectors in region 1-1 [30, 2F] = sector size in multiples of 256-bytes	2E	5C	512Mb	0001
			1Gb	0003
	2F	5E	0000	
	30	60	0002	
Index for Erase Bank Area 2	31	62	0000	
	32	64	0000	
	33	66	0000	
	34	68	0000	
Index for Erase Bank Area 3	35	6A	0000	
	36	6C	0000	
	37	6E	0000	
	38	70	0000	
Index for Erase Bank Area 4	39	72	0000	
	3A	74	0000	
	3B	76	0000	
Reserved	3C	78	0000	
	3D	7A	FFFF	
	3E	7C	FFFF	
	3F	7E	FFFF	

Table 13. CFI MODE: PRIMARY VENDOR-SPECIFIC EXTENDED QUERY DATA VALUES

Description	Address (h) (Word Mode)	Address (h) (Byte Mode)	Data (h)
Query - Primary extended table, unique ASCII string, PRI	40	80	0050
	41	82	0052
	42	84	0049
Major version number, ASCII	43	86	0031
Minor version number, ASCII	44	88	0035
Address sensitive unlock (bits 1 to 0) 00 = supported, 01 = not supported Process Technology (bits 7 to 2)	45	8A	001C
Erase suspend (2= to both read and program)	46	8C	0002
Sector protect (N= # of sectors/group)	47	8E	0001
Temporary sector unprotect (1=supported)	48	90	0001
Sector protect/Chip unprotect scheme	49	92	0008
Simultaneous R/W operation (0=not supported)	4A	94	0000
Burst mode (0=not supported)	4B	96	0000
Page mode (0=not supported, 01 = 4 word page, 02 = 8 word page, 03=16 word page)	4C	98	0003
Minimum ACC(acceleration) supply (0= not supported), [D7:D4] for volt, [D3:D0] for 100mV	4D	9A	0095
Maximum ACC(acceleration) supply (0= not supported), [D7:D4] for volt, [D3:D0] for 100mV	4E	9C	00A5
WP# Protection 04=Uniform sectors bottom WP# protect 05=Uniform sectors top WP# protect	4F	9E	0004/ 0005
Program Suspend (0=not supported, 1=supported)	50	A0	0001
Unlock Bypass 00 = Not Supported 01 = Supported	51	A2	0000
Security Sector (Customer OTP Area) Size 2 ^N (bytes)	52	A4	0009
Software Features bit 0: extended status register (1 = supported, 0 = not supported) bit 1: DQ polling (1 = supported, 0 = not supported) bit 2: new program suspend/resume commands (1 = supported, 0 = not supported) bit 3: word program (1 = supported, 0 = not supported) bit 4: bit-field program (1 = supported, 0 = not supported) bit 5: autodetect program (1 = supported, 0 = not supported) bit 6: RFU bit 7: multiple writes per Line (1 = supported, 0 = not supported)	53	A6	008F
Page Size = 2 ^N bytes	54	A8	0005
Erase Suspend Timeout Maximum < 2 ^N (us)	55	AA	0005
Program Suspend Timeout Maximum < 2 ^N (us)	56	AC	0005
Reserved	57-77	AE-EE	FFFF
Embedded Hardware Reset Timeout Maximum < 2 ^N (us) Reset with Reset Pin	78	F0	0005
Non-Embedded Hardware Reset Timeout Maximum < 2 ^N (us) Power on Reset	79	F2	0009

Note: Query data are always presented on the lowest-order data outputs only.

11. ELECTRICAL CHARACTERISTICS

11-1. ABSOLUTE MAXIMUM STRESS RATINGS

Surrounding Temperature with Bias		-65°C to +125°C
Storage Temperature		-65°C to +150°C
Voltage Range	VCC	-0.5V to +4.0 V
	VI/O	-0.5V to +4.0 V
	A9 , WP#/ACC	-0.5V to +10.5 V
	The other pins.	-0.5V to Vcc +0.5V
Output Short Circuit Current (less than one second)		200 mA

11-2. OPERATING TEMPERATURE AND VOLTAGE

Industrial (I) Grade	Surrounding Temperature (T _A)	-40°C to +85°C
VCC Supply Voltages	Full VCC range	+2.7 V to 3.6 V
	Regulated VCC range	+3.0 V to 3.6 V
	VI/O range	1.65V to VCC

NOTICE:

1. Stresses greater than those listed under ABSOLUTE MAXIMUM RATINGS may cause permanent damage to the device. This is stress rating only and functional operational sections of this specification is not implied. Exposure to absolute maximum rating conditions for extended period may affect reliability.
2. Specifications contained within the following tables are subject to change.
3. During voltage transitions, all pins may overshoot GND to -2.0V and Vcc to +2.0V for periods up to 20ns, see below Figure.

Figure 14. MAXIMUM NEGATIVE OVERSHOOT WAVEFORM

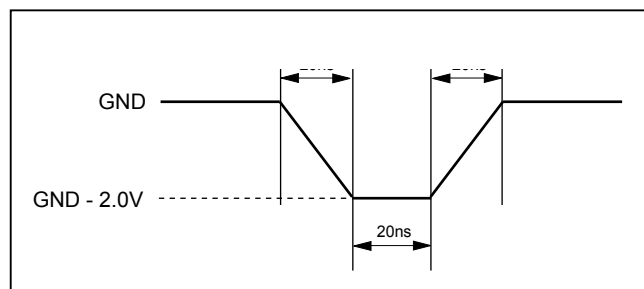
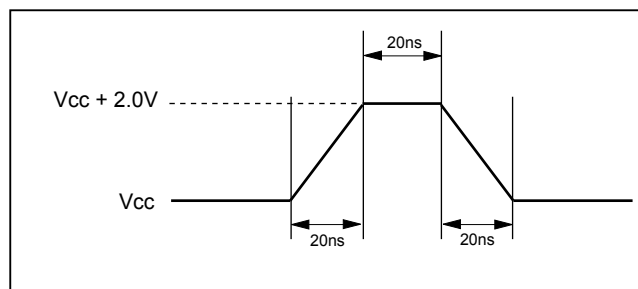
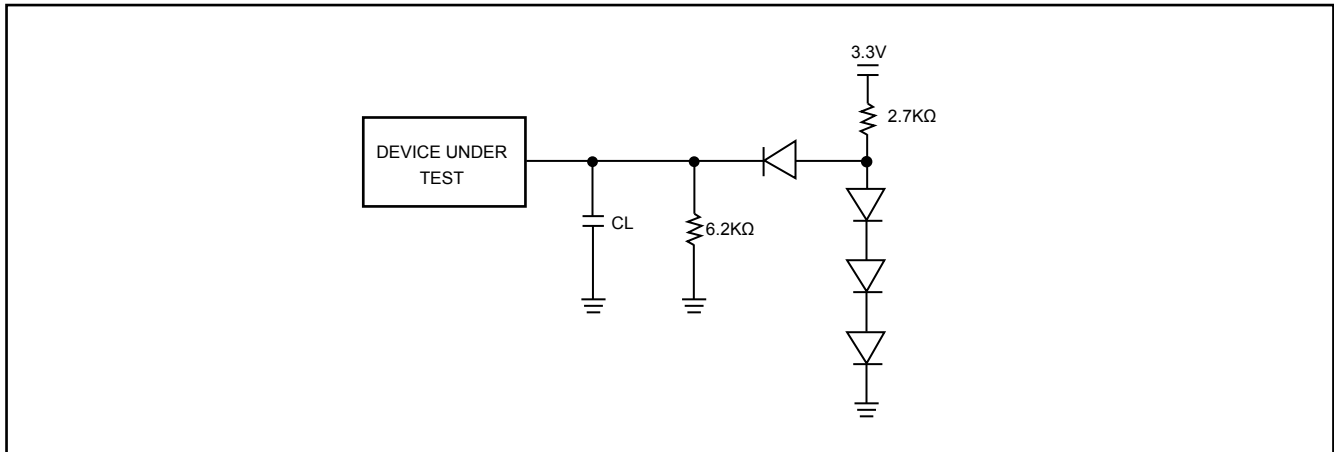

Figure 15. MAXIMUM POSITIVE OVERSHOOT WAVEFORM



11-3. TEST CONDITIONS

Figure 16. SWITCHING TEST CIRCUITS



Test Condition

Output Load Capacitance, CL : 1TTL gate, 30pF

Rise/Fall Times : 5ns

Input Pulse levels : 0.0 ~ V_{I/O}

In/Out reference levels : 0.5V_{I/O}

Figure 17. SWITCHING TEST WAVEFORMS

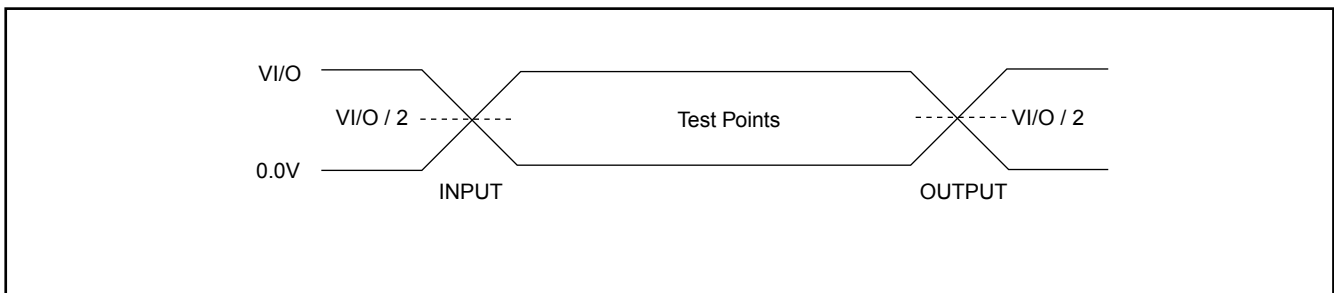

11-4. DC CHARACTERISTICS

Table 14. DC CHARACTERISTICS

Symbol	Description	Min.	Typ.	Max.	Unit	Remark	
lilk	Input Leak			±2.0	uA		
lilkw	WP#/ACC Leak	512Mb		±4.0	uA		
		1Gb		±8.0	uA		
lilk9	A9 Leak	512Mb		20	uA	A9=10.5V	
		1Gb		40	uA		
lolk	Output Leak			±1.0	uA		
lcr1	Read Current	1MHz	512Mb	5	10	mA	CE#=Vil, OE#=Vih, VCC=VCCmax; f=1MHz
			1Gb	5	15	mA	
		5MHz	512Mb	12	30	mA	
			1Gb	12	35	mA	
		10MHz	512Mb	20	35	mA	
			1Gb	20	40	mA	
lcr2	VCC Page Read Current	10MHz	512Mb	4	8	mA	CE#=Vil, OE#=Vih, VCC=VCCmax; f=10MHz
			1Gb	8	15	mA	
		33MHz	512Mb	6	12	mA	
			1Gb	12	24	mA	
lio	VI/O non-active current	512Mb	0.2	10	mA		
		1Gb	0.4	20	mA		
lcw	Write Current	512Mb	35	55	mA	CE#=Vil, OE#=Vih, WE#=Vil	
		1Gb	35	55	mA		
lsb	Standby Current	512Mb	20	90	uA	VCC=VCCmax, CE#=OE#=RESET# =VIO	
		1Gb	40	180	uA		
lsbr	Reset Current	512Mb	20	90	uA	VCC=VCCmax, RESET#=GND, CE#=Vih	
		1Gb	40	180	uA		
lsbs	Sleep Mode Current	512Mb	20	90	uA	VCC=VCCmax, Vil=GND, Vih=VI/O	
		1Gb	40	180	uA		
ldpd	Vcc deep power down current	512Mb	3	15	uA	VCC=VCCmax, CE#=OE#=RESET# =VIO	
		1Gb	6	30	uA		

Symbol	Description	Min.	Typ.	Max.	Unit	Remark
Icp1	Accelerated Pgm Current, WP#/ACC pin (Word/Byte)		2	5	mA	CE#=Vil, OE#=Vih
Icp2	Accelerated Pgm Current, VCC pin, (Word/Byte)		14	28	mA	CE#=Vil, OE#=Vih
Vil	Input Low Voltage	-0.1V		0.3xVI/O	V	
Vih	Input High Voltage	0.7xVI/O		VI/O+0.3V	V	
Vhv	Very High Voltage for Auto Select/ Accelerated Program	9.5		10.5	V	
Vol	Output Low Voltage			0.45	V	Iol=100uA
Voh	Output High Voltage	0.85xVI/O			V	Ioh=-100uA
Vlko	Low Vcc Lock-out voltage	2.1		2.4	V	

Note: Sleep mode enables the lower power when address remain stable for $t_{aa}+1\mu s$.

11-5. AC CHARACTERISTICS

Table 15. AC CHARACTERISTICS

Symbol	Description	VCC=2.7V to 3.6V			Unit
		Min.	Typ.	Max.	
Taa	Valid data output after address	VI/O=VCC		100	ns
		VI/O=1.65 to VCC		110	ns
Tpa	Page access time	VI/O=VCC		15	ns
		VI/O=1.65 to VCC		25	ns
Tce	Valid data output after CE# low	VI/O=VCC		100	ns
		VI/O=1.65 to VCC		110	ns
Toe	Valid data output after OE# low	VI/O=VCC		25	ns
		VI/O=1.65 to VCC		30	ns
Tdf	Data output floating after OE# high or CE# high			20	ns
Tsrw	Latency between read and write operation (Note)	35			ns
Toh	Output hold time from the earliest rising edge of address, CE#, OE#	0			ns
Trc	Read period time	100			ns
Twc	Write period time	100			ns
Tcwc	Command write period time	100			ns
Tas	Address setup time	0			ns
Taso	Address setup time to OE# low during toggle bit polling	15			ns
Tah	Address hold time	45			ns
Taht	Address hold time from CE# or OE# high during toggle bit polling	0			ns
Tds	Data setup time	30			ns
Tdh	Data hold time	0			ns
Tvcs	Vcc setup time	500			us
Tcs	Chip enable Setup time	0			ns
Tch	Chip enable hold time	0			ns
Toeh	Output enable hold time	Read	0		ns
		Toggle & Data# Polling	10		ns

Symbol	Description	VCC=2.7V to 3.6V			Unit
		Min.	Typ.	Max.	
Tws	WE# setup time	0			ns
Twh	WE# hold time	0			ns
Tcepw	CE# pulse width	35			ns
Tcepwh	CE# pulse width high	30			ns
Twp	WE# pulse width	35			ns
Twph	WE# pulse width high	30			ns
Tbusy	Program/Erase active time by RY/BY#	VI/O=VCC		100	ns
		VI/O=1.65 to VCC		110	ns
Tghwl	Read recover time before write (under WE# control)	0			ns
Tghel	Read recover time before write (under CE# control)	0			ns
Toeph	Output enable high during toggle bit polling or following extended status register read	20			ns
Tceph	Chip enable high during toggle bit polling or following extended status register read	20			ns
Twhwh1	Program operation	Byte		30	us
		Word		30	us
Twhwh2	Sector erase operation		0.25	1.4	sec

Note: Not 100% tested.

11-6. WRITE COMMAND OPERATION

Figure 18. COMMAND WRITE TIMING WAVEFORM (WE# CONTROLLED)

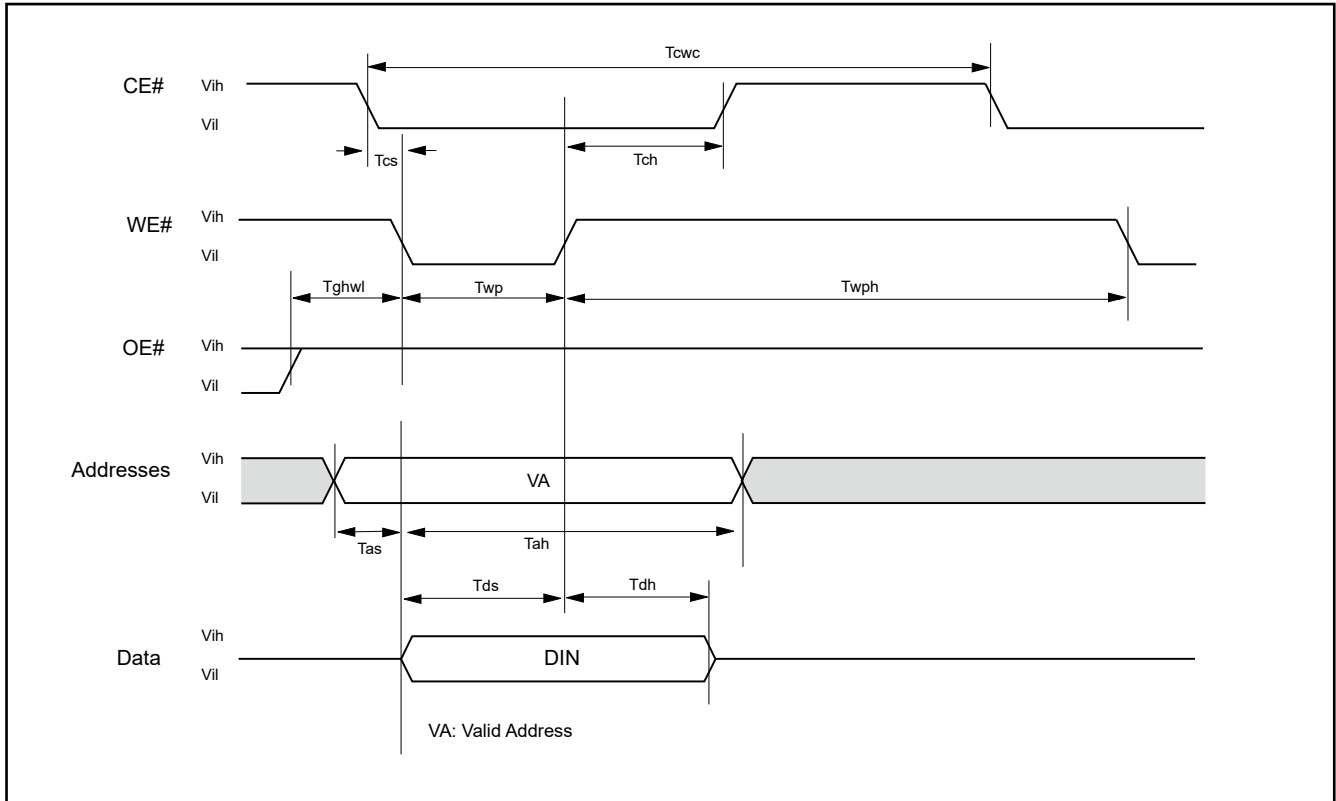
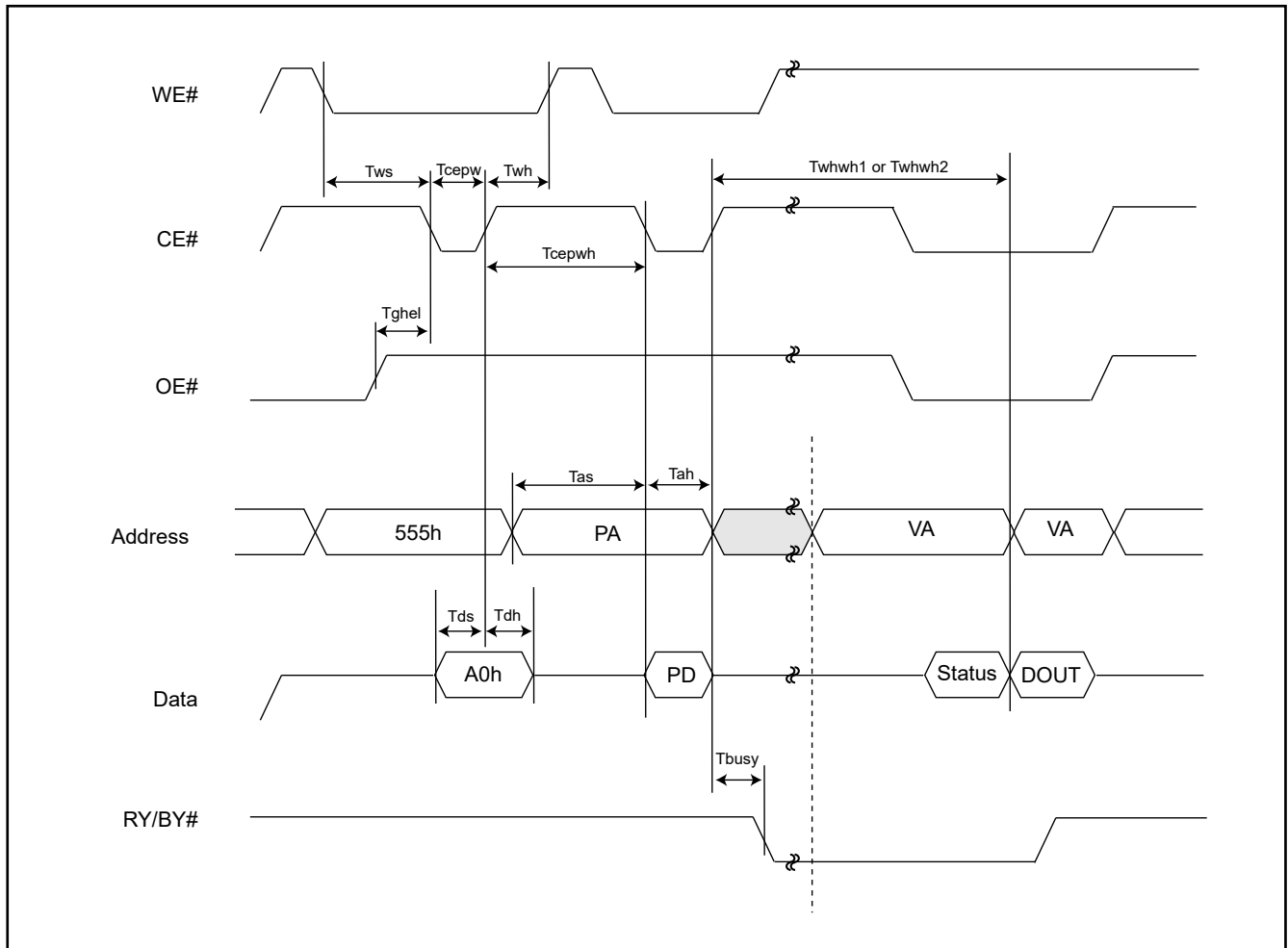

Figure 19. COMMAND WRITE TIMING WAVEFORM (CE# CONTROLLED)



11-7. READ/RESET OPERATION

Figure 20. READ TIMING WAVEFORM

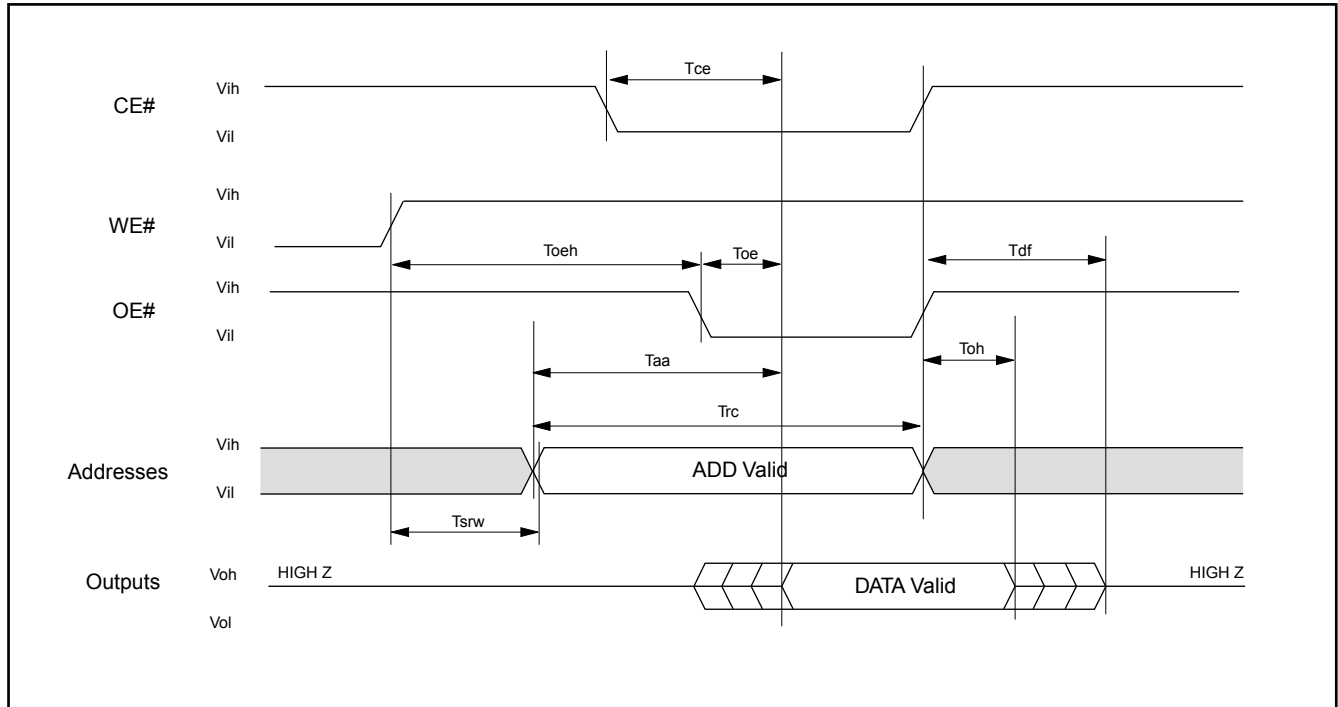

Figure 21. PAGE READ TIMING WAVEFORM

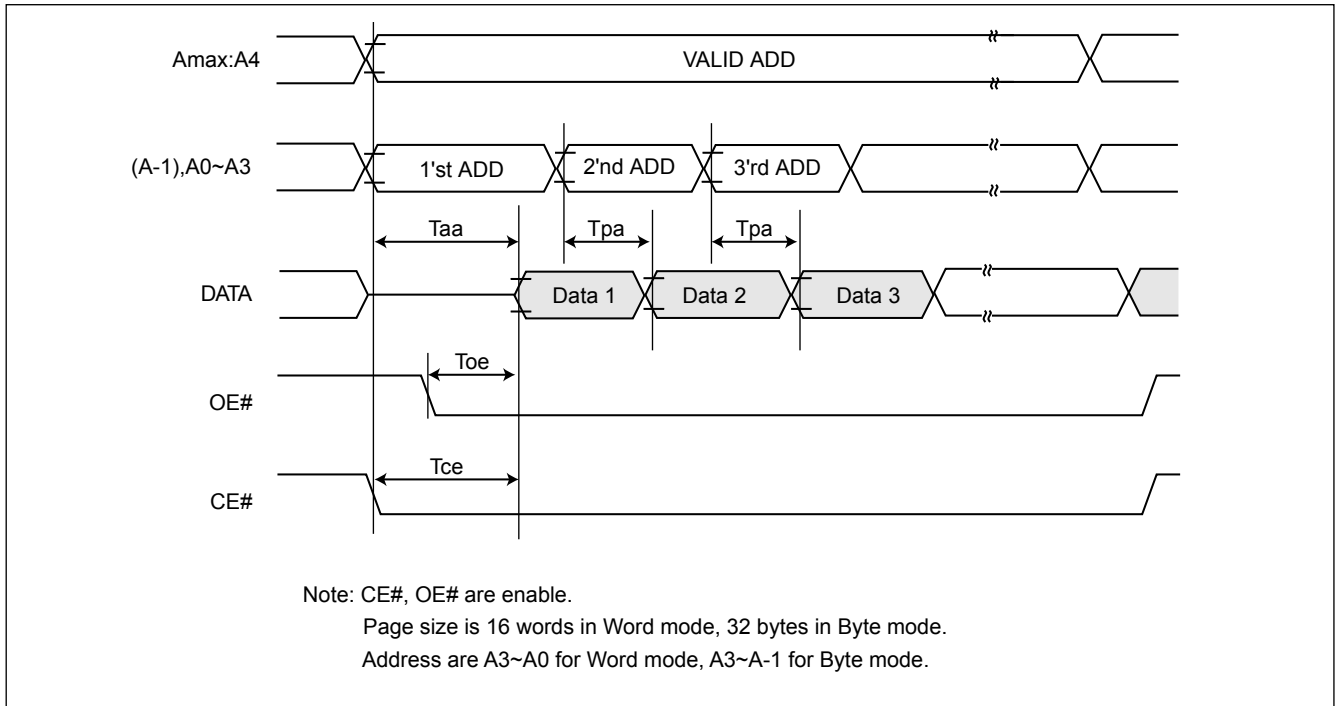

Figure 22. READ MANUFACTURER ID OR DEVICE ID

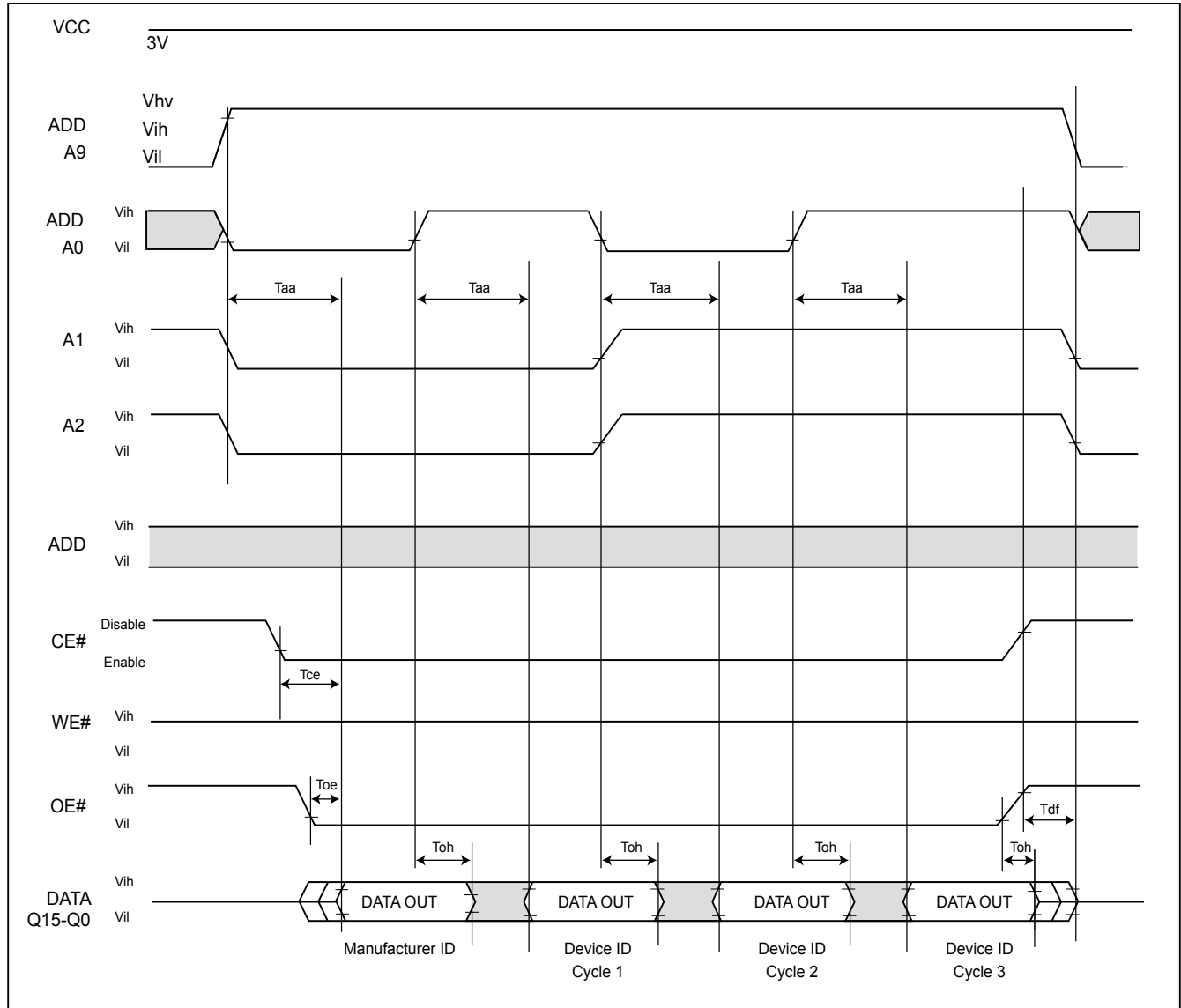

Figure 23. RESET# TIMING WAVEFORM

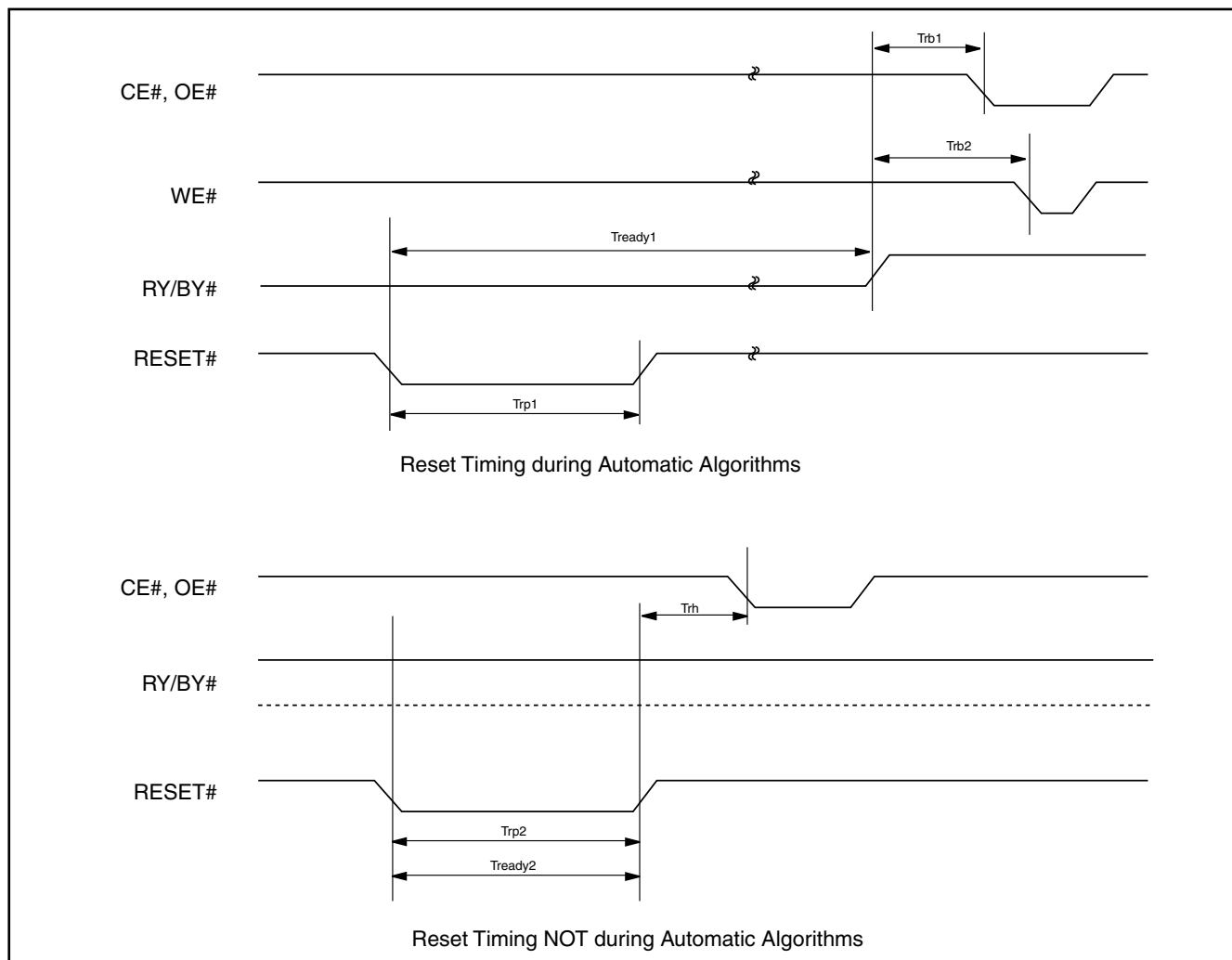

Table 16. AC CHARACTERISTICS (RESET# TIMING)

Symbol	Description	Min.	Typ.	Max.	Unit
Trp1	RESET# Pulse Width (During Automatic Algorithms)	10			us
Trp2	RESET# Pulse Width (NOT During Automatic Algorithms)	200			ns
Trh	RESET# High Time Before Read	50			ns
Trb1	RY/BY# Recovery Time (to CE#, OE# go low)	0			ns
Trb2	RY/BY# Recovery Time (to WE# go low)	50			ns
Tready1	RESET# PIN Low (During Automatic Algorithms) to Read or Write			30	us
Tready2	RESET# PIN Low (NOT During Automatic Algorithms) to Read or Write			500	ns
Tesl	Erase Suspend/Resume Latency			30	us
Tpsl	Program Suspend/Resume Latency			30	us
Tprs	Latency between program resume and next suspend		30		us
Ters	Latency between erase resume and next suspend		400		us

Figure 24. DEEP POWER DOWN MODE TIMING WAVEFORM

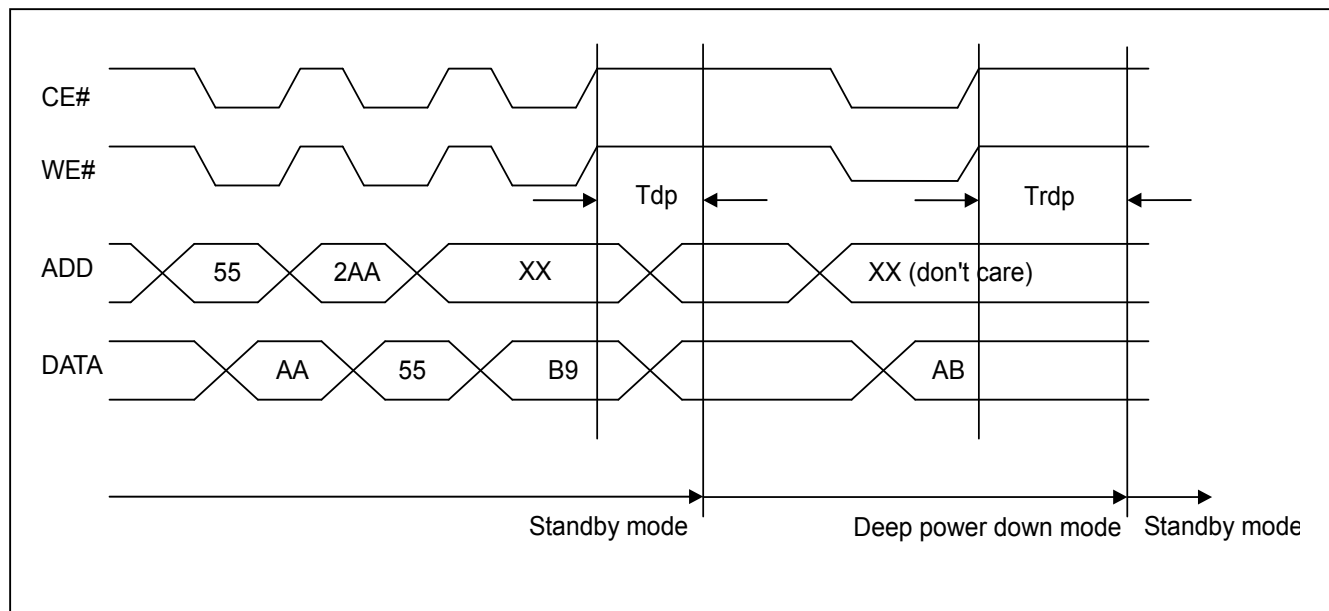

Table 17. AC CHARACTERISTICS (Deep Power Down Mode TIMING)

Symbol	Description	Typ.	Max.	Unit
Trdp	WE# high to release from deep power down mode	100us	200us	us
Tdp	WE# high to deep power down mode	10us	20us	us

11-8. ERASE/PROGRAM OPERATION

Figure 25. AUTOMATIC CHIP ERASE TIMING WAVEFORM

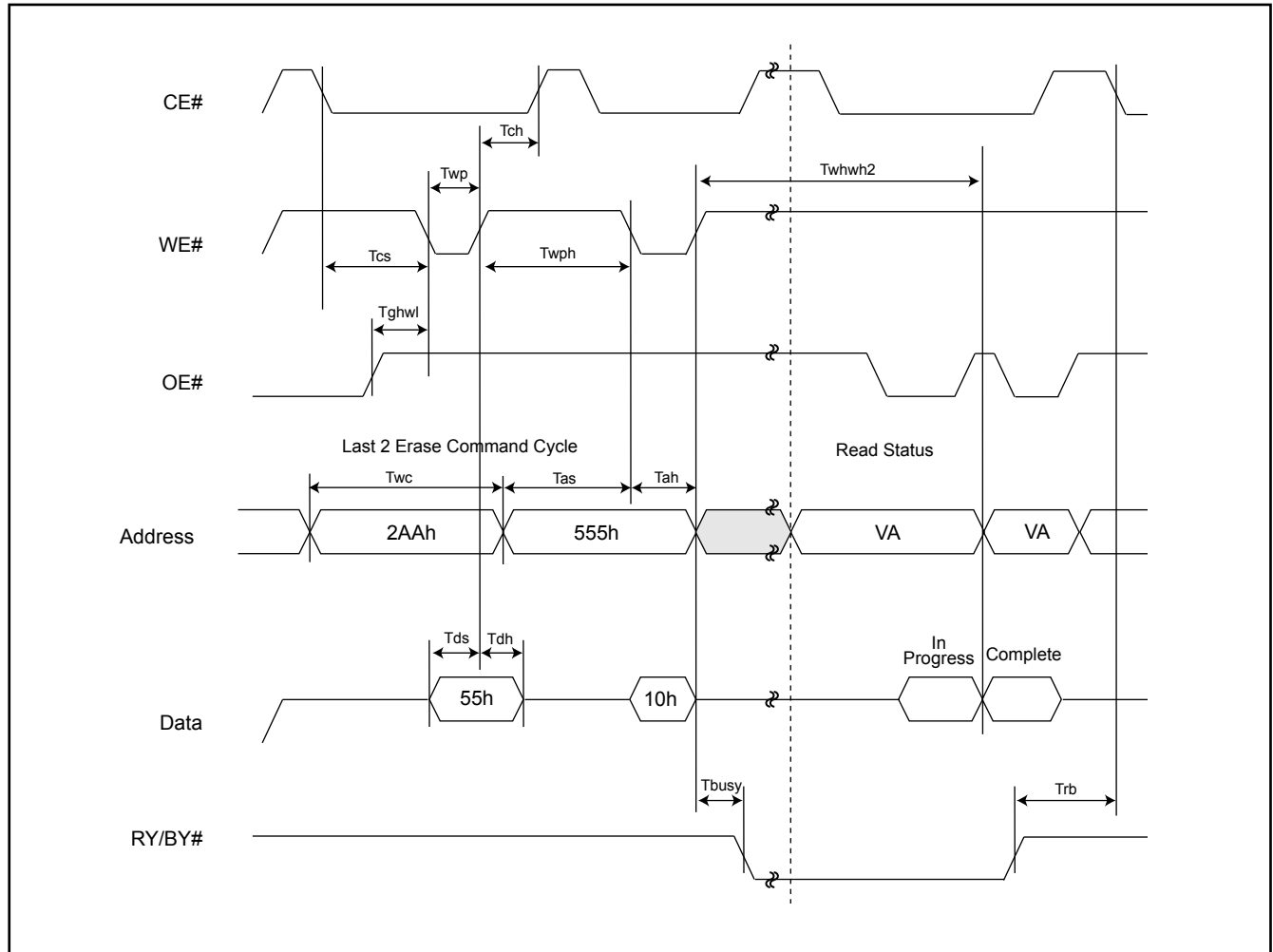

Figure 26. AUTOMATIC SECTOR ERASE TIMING WAVEFORM

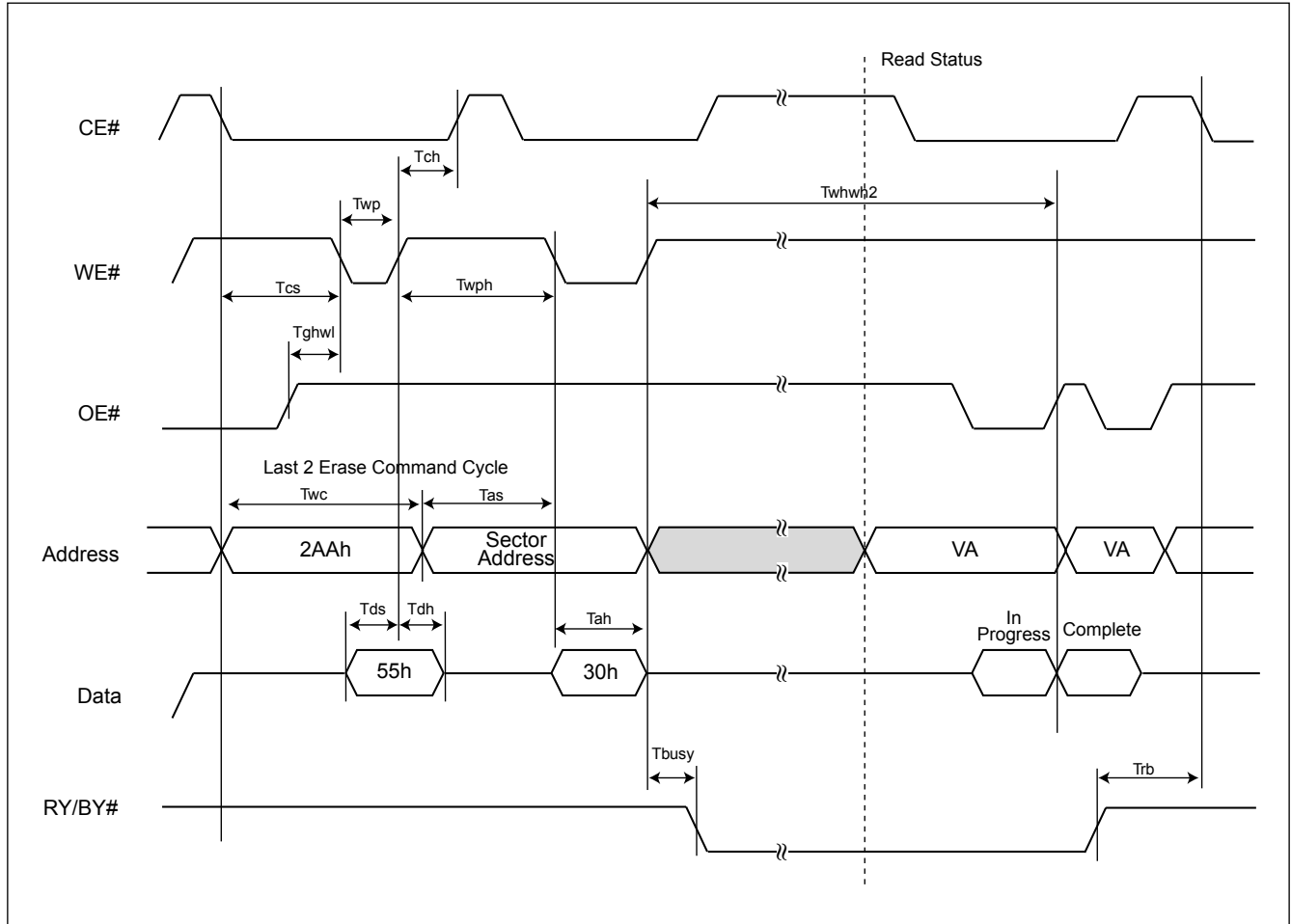

Figure 27. AUTOMATIC PROGRAM TIMING WAVEFORM

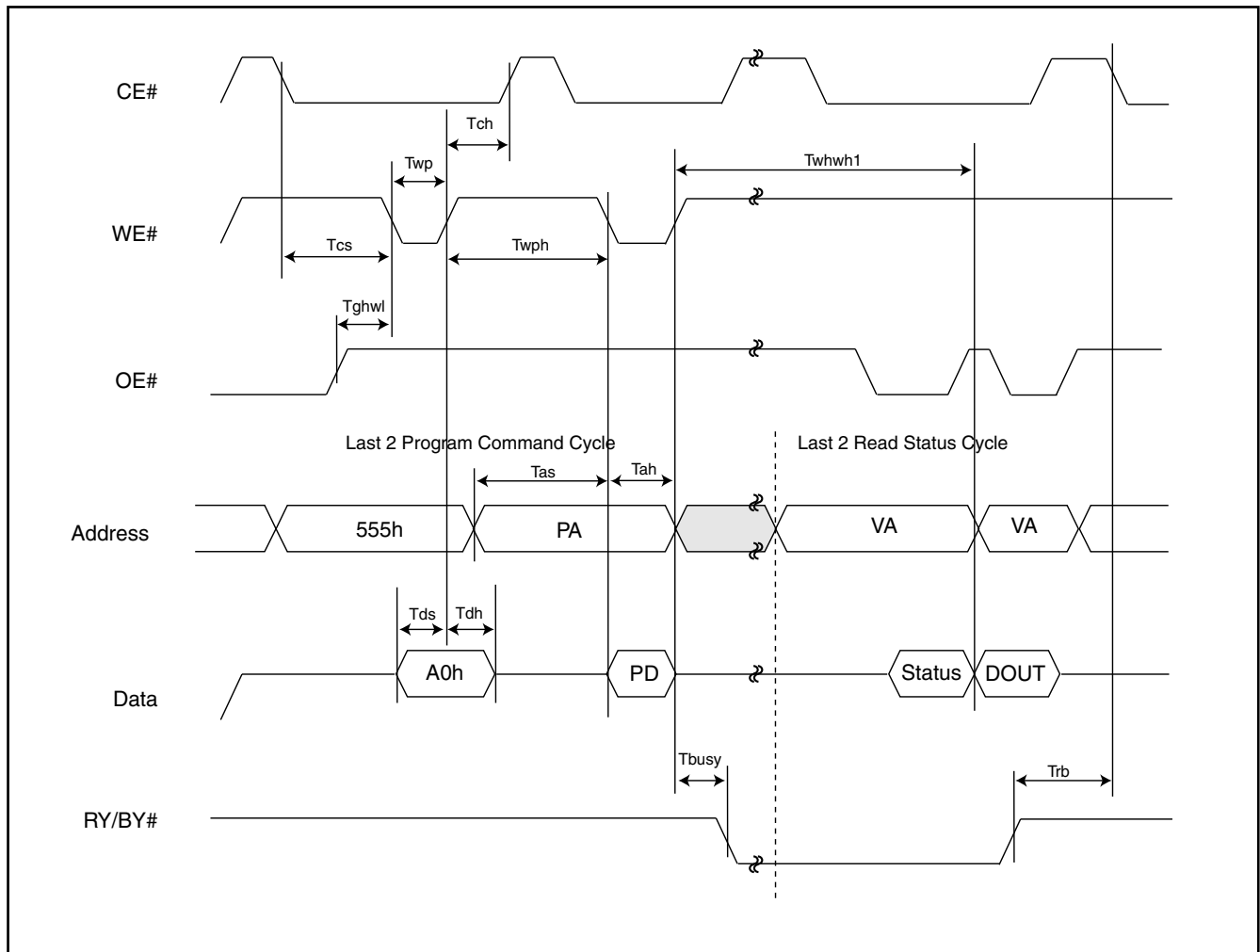
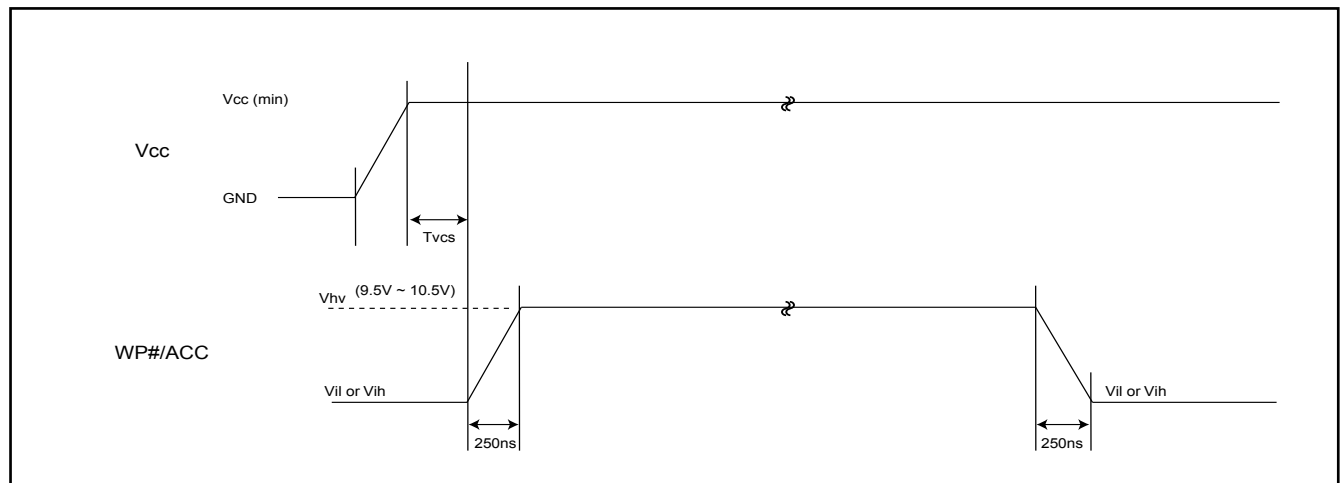

Figure 28. ACCELERATED PROGRAM TIMING WAVEFORM

11-9. WRITE STATUS OPERATION

Figure 29. DATA# POLLING TIMING WAVEFORM (for AUTOMATIC MODE)

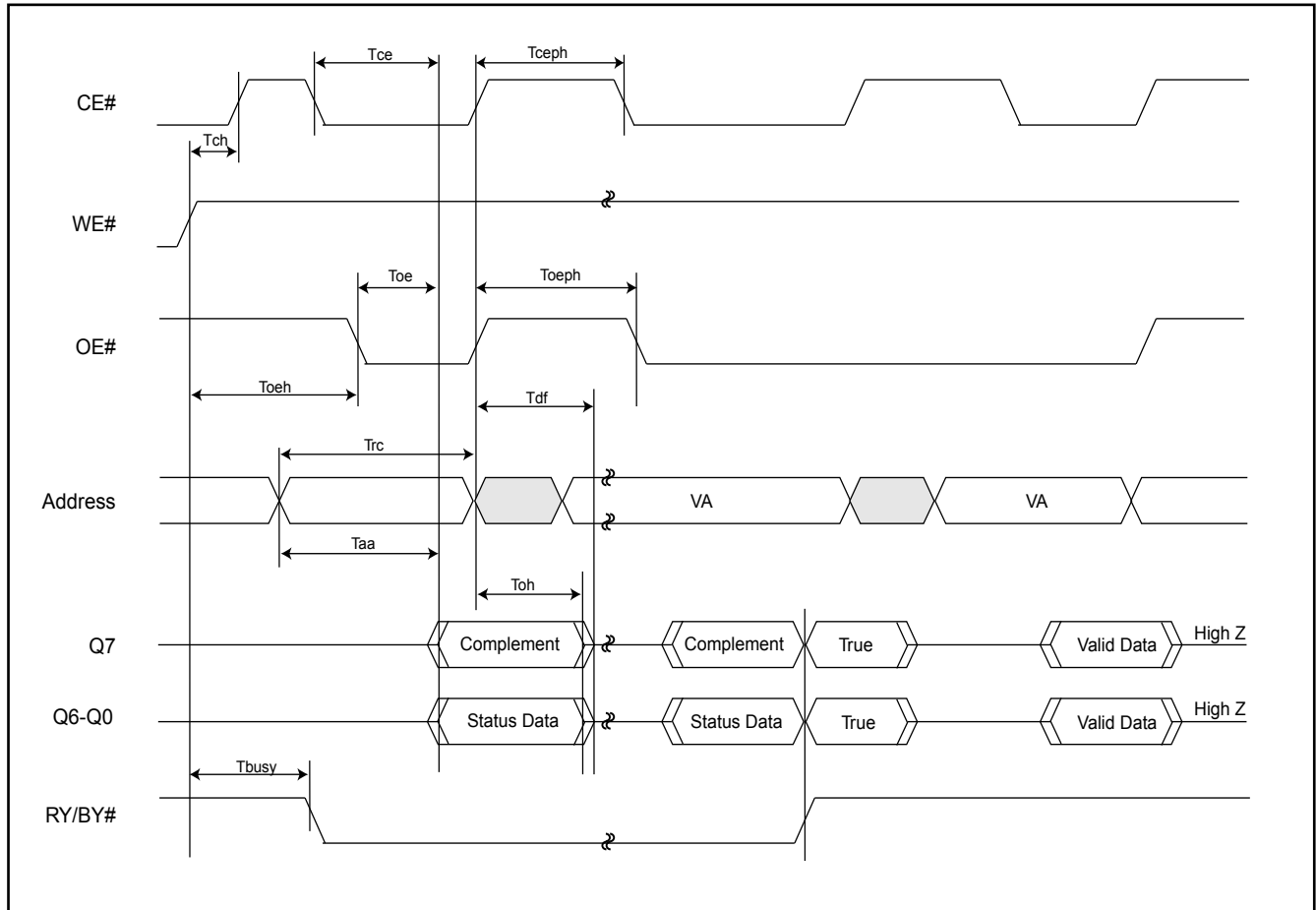
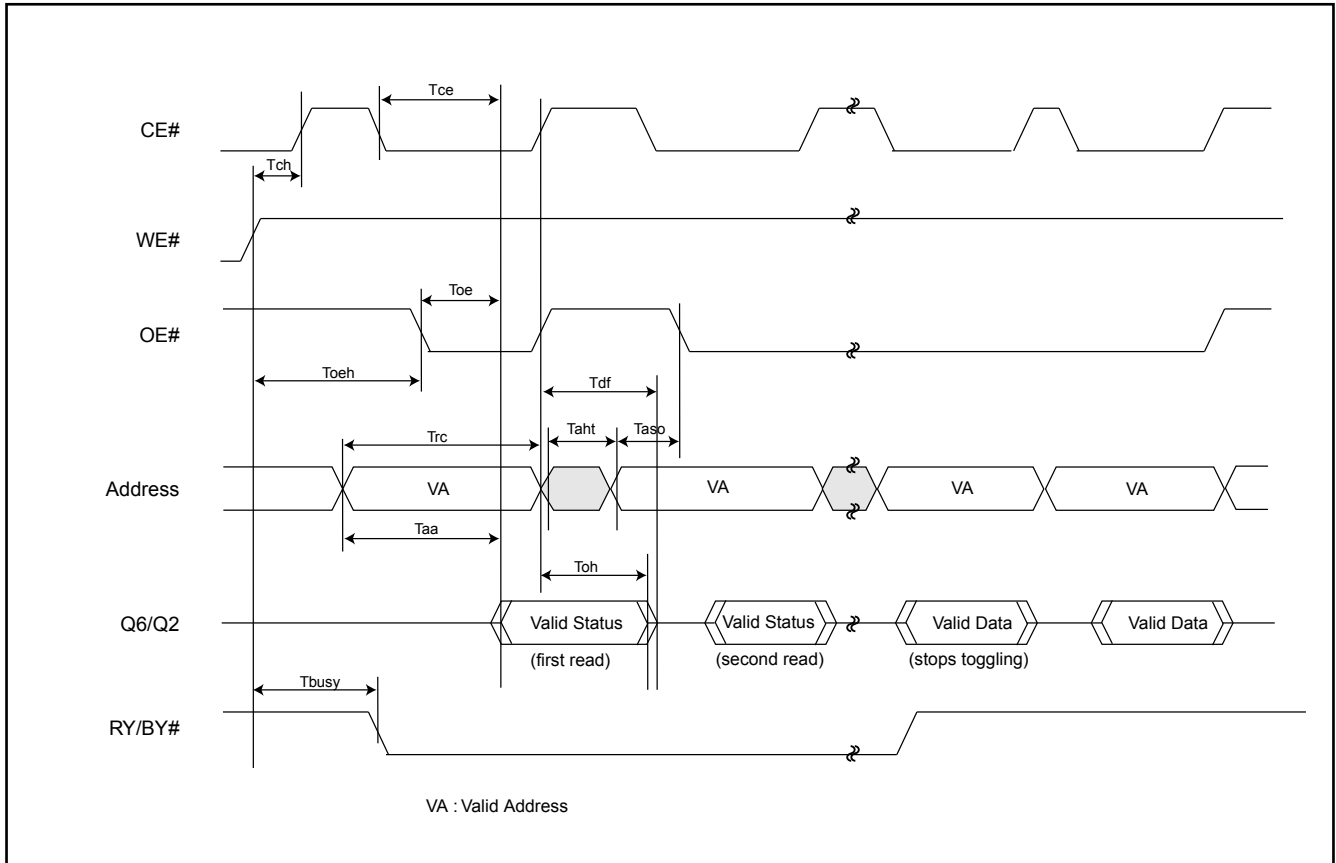

Figure 30. TOGGLE BIT TIMING WAVEFORM



11-10. RECOMMENDED OPERATING CONDITIONS

11-10-1. At Device Power-Up

AC timing illustrated in "Figure 31. AC TIMING AT DEVICE POWER-UP" is recommended for the supply voltages and the control signals at device power-up (e.g. Vcc and CE# ramp up simultaneously). If the timing in the figure is ignored, the device may not operate correctly.

Figure 31. AC TIMING AT DEVICE POWER-UP

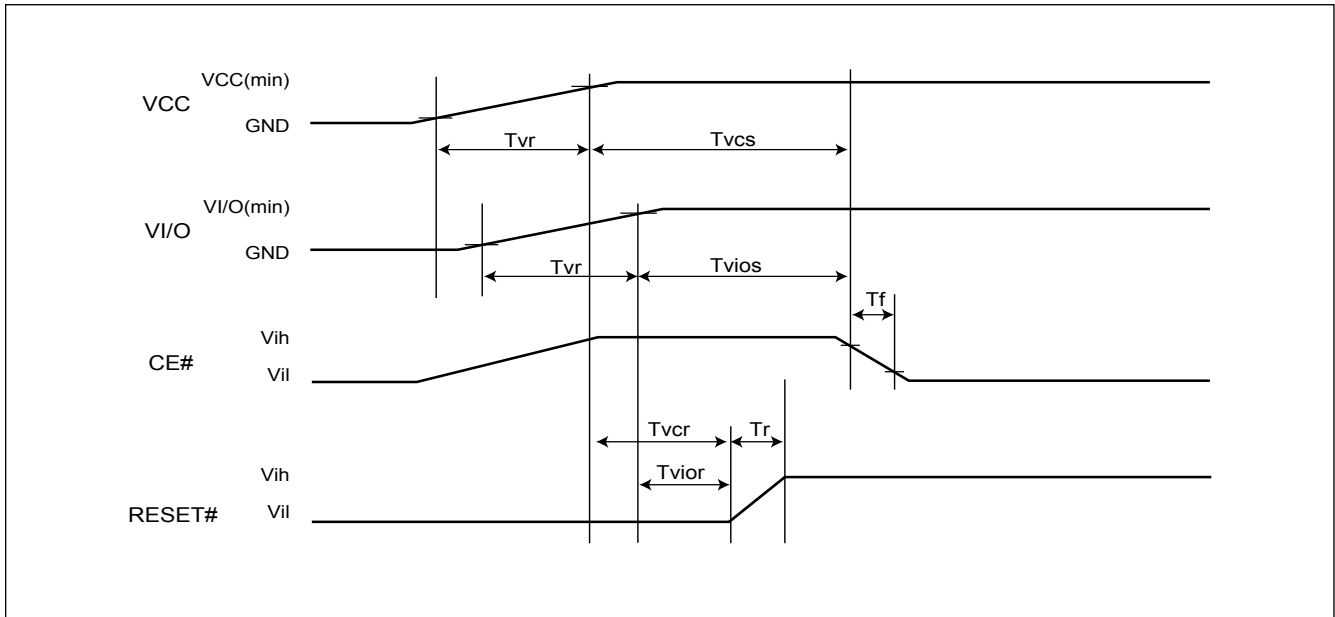

Table 18. AC CHARACTERISTICS (AC TIMING AT DEVICE POWER-UP)

Symbol	Parameter	Min.	Max.	Unit
Tvr	VCC Rise Time		500000	us/V
Tr	Input Signal Rise Time		20	us/V
Tf	Input Signal Fall Time		20	us/V
Tvcs/Tvcr	VCC Setup Time	300		us
Tvios/Tvior	VI/O Setup Time	300		us

Notes:

1. Not 100% test.
2. VI/O < VCC+200mV.

11-10-2. Power Up/Down and Voltage Drop

When powering down the device, VCC must drop below V_{PVD} for at least T_{PVD} to ensure the device will initialize correctly during power up. Please refer to "Figure 32. POWER UP/DOWN AND VOLTAGE DROP" and "Table 19. AC CHARACTERISTICS (POWER UP/DOWN AND VOLTAGE DROP)" below for more details.

Figure 32. POWER UP/DOWN AND VOLTAGE DROP

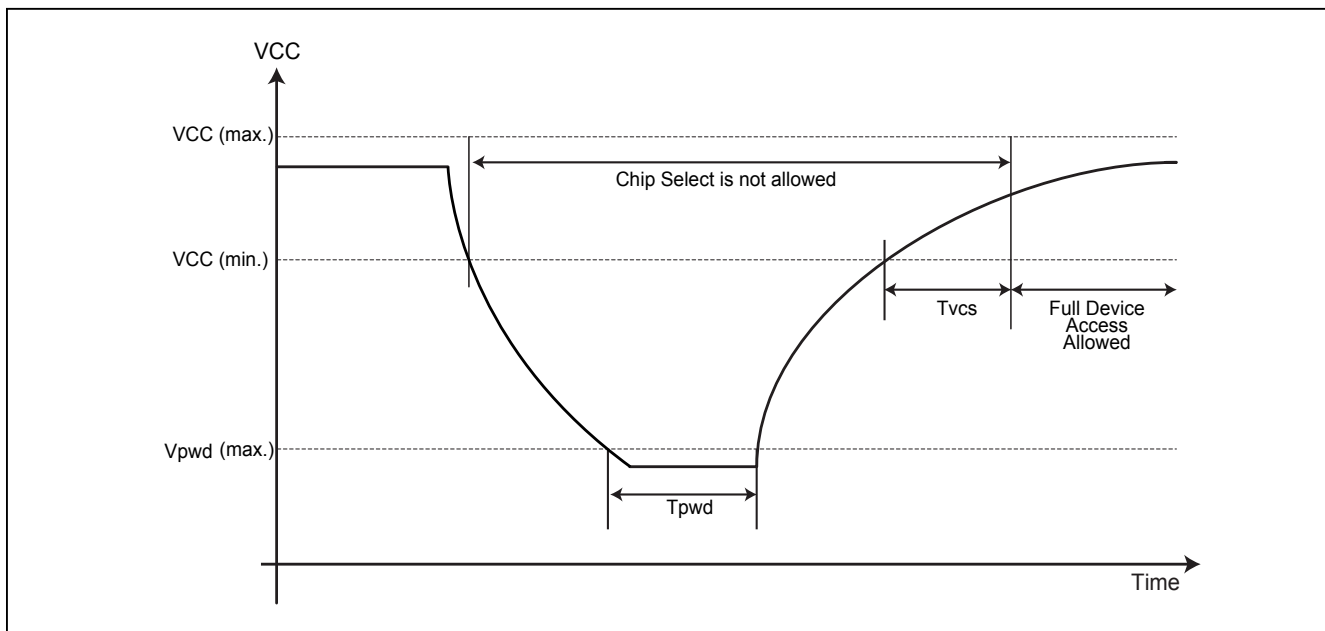

Table 19. AC CHARACTERISTICS (POWER UP/DOWN AND VOLTAGE DROP)

Symbol	Parameter	Min.	Max.	Unit
Vpwd	Voltage level below which device needs to be re-initialized		0.9	V
Tpwd	Time interval for VCC is below Vpwd	300		us
Tvcs	VCC Setup Time	300		us
Tvr	VCC Rise Time		500000	us/V
VCC	VCC Power Supply	2.7	3.6	V

Notes:

1. Not 100% test.

11-11. ERASE AND PROGRAM PERFORMANCE

Description		Limits		Units
		Typ.(1)	Max.(2)	
Chip Erase Time	512Mb	100	250	sec
	1Gb	200	500	sec
Sector Erase Time		0.25	1.4	sec
Word Program Time		30	230	us
Total Write Buffer Time		284	1,400	us
Total ACC Write Buffer Time		200		us
Erase/Program Cycles		100,000		Cycles
Blank Check			10	ms

Notes:

1. Typical program and erase times assume the following conditions: 25°C, 3.0V VCC. Program specifications assume checkboard data pattern.
2. Maximum values are measured at VCC = 3.0V, worst case temperature. Maximum values are valid up to and including 100,000 program/erase cycles.
3. Erase/Program cycles comply with JEDEC JESD-47 & JESD 22-A117 standard.
4. Exclude 00h program before erase operation.

11-12. DATA RETENTION

Description	Condition	Min.	Max.	Unit
Data retention	55°C	20		years

11-13. LATCH-UP CHARACTERISTICS

Description	Min.	Max.
Input Voltage voltage difference with GND on WP#/ACC and A9 pins	-1.0V	10.5V
Input Voltage voltage difference with GND on all normal pins input	-1.0V	1.5Vcc
Vcc Current	-100mA	+100mA

Notes:

1. All pins included except VCC. Test conditions: VCC = 3.0V, one pin per testing

11-14. PIN CAPACITANCE

Table 20. PIN CAPACITANCE: 56-TSOP

Symbol	Description		Typ.	Max.	Unit	Remark
CIN2	Control Pin Capacitance	512Mb	3	7	pF	VIN=0
		1Gb	6	14	pF	
CIN	Input Capacitance	512Mb	7	8	pF	VIN=0
		1Gb	14	16	pF	
COUT	Output Capacitance	512Mb	5	6	pF	VOUT=0
		1Gb	10	12	pF	
RY/BY#	Output Capacitance	512Mb	3	4	pF	VOUT=0
		1Gb	6	8	pF	

Notes:

1. Not 100% tested, WP#/ACC pin not included.

Table 21. PIN CAPACITANCE: 64-LFBGA

Symbol	Description		Typ.	Max.	Unit	Remark
CIN2	Control Pin Capacitance	512Mb	4	9	pF	VIN=0
		1Gb	8	18	pF	
CIN	Input Capacitance	512Mb	8	9	pF	VIN=0
		1Gb	16	18	pF	
COUT	Output Capacitance	512Mb	5	7	pF	VOUT=0
		1Gb	10	14	pF	
RY/BY#	Output Capacitance	512Mb	3	4	pF	VOUT=0
		1Gb	6	8	pF	

Notes:

1. Not 100% tested, WP#/ACC pin not included.

12. ORDERING INFORMATION

Please contact Macronix regional sales for the latest product selection and available form factors.

PART NO.	ACCESS TIME (ns)		PACKAGE	Remark
	Vcc=3.0 to 3.6V	Vcc=2.7 to 3.6V		
MX29GL512G				
MX29GL512GHXFI-10G	100	100	64 LFBGA	VI/O=VCC
MX29GL512GLXFI-10G	100	100	64 LFBGA	VI/O=VCC
MX29GL512GHT2I-10G	100	100	56 Pin TSOP	VI/O=VCC
MX29GL512GLT2I-10G	100	100	56 Pin TSOP	VI/O=VCC
MX29GL512GUXFI-11G	110	110	64 LFBGA	VI/O=1.65 to VCC
MX29GL512GDXFI-11G	110	110	64 LFBGA	VI/O=1.65 to VCC
MX29GL512GUT2I-11G	110	110	56 Pin TSOP	VI/O=1.65 to VCC
MX29GL512GDT2I-11G	110	110	56 Pin TSOP	VI/O=1.65 to VCC
MX29GL512GHXFI-10Q	95	100	64 LFBGA	VI/O=VCC
MX29GL512GLXFI-10Q	95	100	64 LFBGA	VI/O=VCC
MX29GL512GHT2I-10Q	95	100	56 Pin TSOP	VI/O=VCC
MX29GL512GLT2I-10Q	95	100	56 Pin TSOP	VI/O=VCC
MX29GL512GUXFI-11Q	105	110	64 LFBGA	VI/O=1.65 to VCC
MX29GL512GDXFI-11Q	105	110	64 LFBGA	VI/O=1.65 to VCC
MX29GL512GUT2I-11Q	105	110	56 Pin TSOP	VI/O=1.65 to VCC
MX29GL512GDT2I-11Q	105	110	56 Pin TSOP	VI/O=1.65 to VCC
MX68GL1G0G				
MX68GL1G0GHT2I-10G	100	100	56 Pin TSOP	VI/O=VCC
MX68GL1G0GLT2I-10G	100	100	56 Pin TSOP	VI/O=VCC
MX68GL1G0GUT2I-11G	110	110	56 Pin TSOP	VI/O=1.65 to VCC
MX68GL1G0GDT2I-11G	110	110	56 Pin TSOP	VI/O=1.65 to VCC
MX68GL1G0GHT2I-10Q	95	100	56 Pin TSOP	VI/O=VCC
MX68GL1G0GLT2I-10Q	95	100	56 Pin TSOP	VI/O=VCC
MX68GL1G0GUT2I-11Q	105	110	56 Pin TSOP	VI/O=1.65 to VCC
MX68GL1G0GDT2I-11Q	105	110	56 Pin TSOP	VI/O=1.65 to VCC
MX68GL1G0GHXFI-10Q*	95	100	64 LFBGA	VI/O=VCC
MX68GL1G0GLXFI-10Q*	95	100	64 LFBGA	VI/O=VCC
MX68GL1G0GUXFI-11Q*	105	110	64 LFBGA	VI/O=1.65 to VCC
MX68GL1G0GDXFI-11Q*	105	110	64 LFBGA	VI/O=1.65 to VCC

Notes: *Advanced Information

13. PART NAME DESCRIPTION

MX 29 GL 512 G H T2 I -10 G

OPTION:

G: RoHS Compliant & Halogen-free

Q: RoHS Compliant & Halogen-free with Fast Speed under Vcc: 3.0V to 3.6V condition (Note)

SPEED:

10: 100ns

11: 110ns

TEMPERATURE RANGE:

I: Industrial (-40° C to 85° C)

PACKAGE:

T2: 56-TSOP

XF: LFBGA (11mm x 13mm x 1.4mm, 0.6 ball size, 1.0 ball-pitch)

PRODUCT TYPE: (WP#=VIL)

H: VI/O=VCC=2.7 to 3.6V, Highest Address Sector Protected

L: VI/O=VCC=2.7 to 3.6V, Lowest Address Sector Protected

U: VI/O=1.65 to VCC, VCC=2.7 to 3.6V, Highest Address Sector Protected

D: VI/O=1.65 to VCC, VCC=2.7 to 3.6V, Lowest Address Sector Protected

REVISION:

G

DENSITY & MODE:

512: 512Mb x8/x16 Architecture

1G0: 1Gb x8/x16 Architecture

TYPE:

GL: 3V Page Mode

DEVICE:

29: Monolithic Die Flash

68: Stack Die Flash

Note:10Q covers 2.7~3.6V for 100ns and 3.0~3.6V for 95ns

11Q covers 2.7~3.6V for 110ns and 3.0~3.6V for 105ns

14. PACKAGE INFORMATION

56-Pin TSOP

Doc. Title: Package Outline for TSOP(I) 56L (14X20mm)

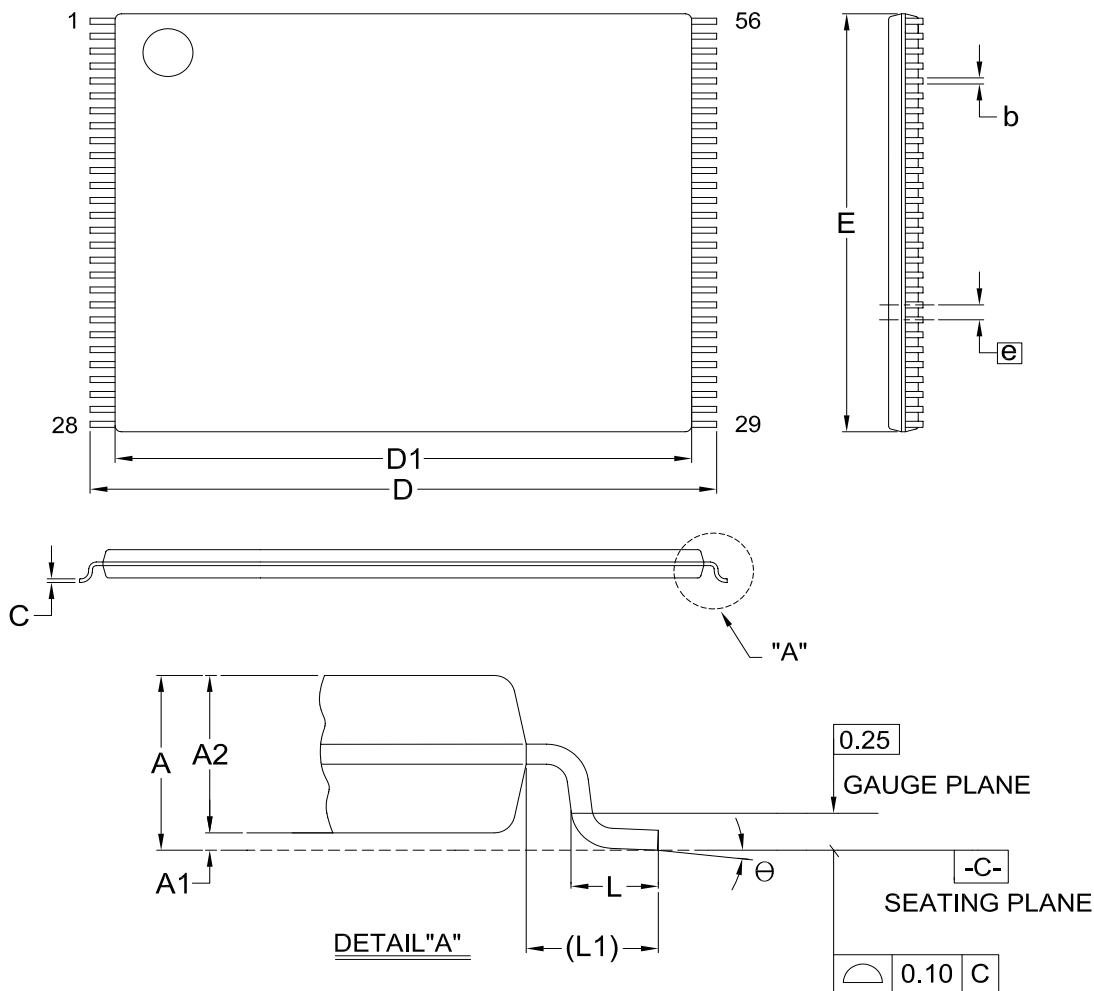

Dimensions (inch dimensions are derived from the original mm dimensions)

SYMBOL		A	A1	A2	b	C	D	D1	E	e	L	L1	θ
mm	Min.	—	0.05	0.95	0.17	0.10	19.80	18.30	13.90	—	0.50	0.70	0°
	Nom.	---	0.10	1.00	0.20	0.13	20.00	18.40	14.00	0.50	0.60	0.80	5°
	Max.	1.20	0.15	1.05	0.27	0.21	20.20	18.50	14.10	—	0.70	0.90	8°
Inch	Min.	---	0.002	0.037	0.007	0.004	0.780	0.720	0.547	—	0.020	0.028	0°
	Nom.	---	0.004	0.039	0.008	0.005	0.787	0.724	0.551	0.020	0.024	0.031	5°
	Max.	0.047	0.006	0.041	0.011	0.008	0.795	0.728	0.555	—	0.028	0.035	8°

64-Ball LFBGA (11mm x 13mm)

Doc. Title: Package Outline for CSP 64BALL(11X13X1.4MM,BALL PITCH 1.00MM,BALL DIAMETER 0.6MM)

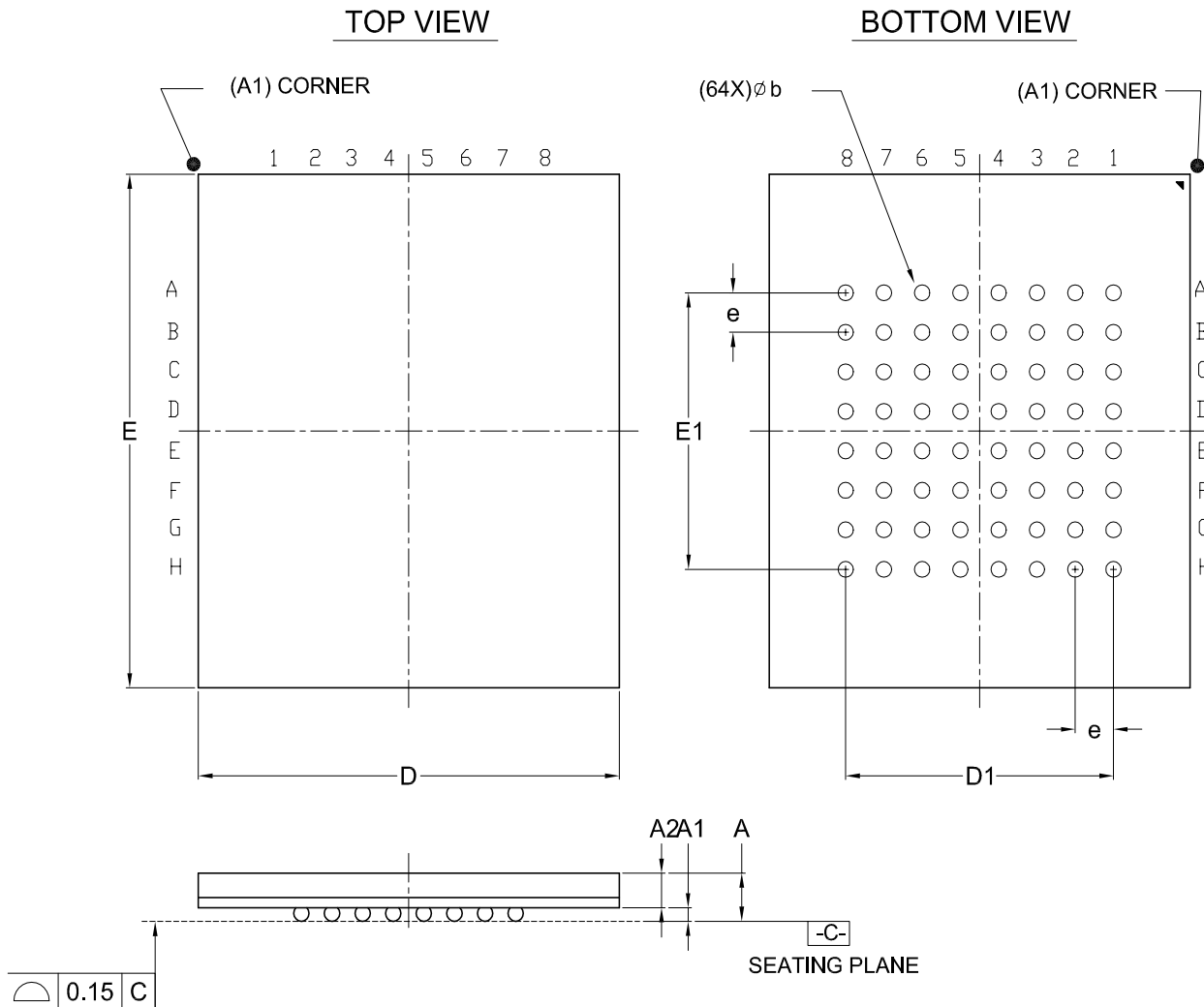

Dimensions (inch dimensions are derived from the original mm dimensions)

SYMBOL		A	A1	A2	b	D	D1	E	E1	e
UNIT										
mm	Min.	---	0.40	0.65	0.50	10.90		12.90		
	Nom.	---	0.50	---	0.60	11.00	7.00	13.00	7.00	1.00
	Max.	1.40	0.60	---	0.70	11.10		13.10		
Inch	Min.	---	0.016	0.026	0.020	0.429		0.508		
	Nom.	---	0.020	---	0.024	0.433	0.276	0.512	0.276	0.039
	Max.	0.055	0.024	---	0.028	0.437		0.516		

15. REVISION HISTORY

Revision No.	Description	Page	Date
0.01	1. Modified descriptions, figures and tables 2. Removed Multi-sector Erase Function 3. Modified parameters of "CFI Mode" Table 4. Modified parameters of "ERASE AND PROGRAM PERFORMANCE" Table 5. Modified DC Characteristics, Reset timing & Program, Erase Suspend / Resume latency	All P21,22,62 P45~47 P6,53,69 P50,51,59	JAN/23/2014
1.0	1. Removed 56-Ball FBGA Package 2. Modified DC Characteristics Table 3. Modified Reset#, AC Power-Up, Power Up/Down Timing Table 4. Modified parameters of "Erase and Program Performance" Table 5. Modified PIN Capacitance 6. Separate 256Mb part from this datasheet revision 7. Removed Preliminary status	P7,9 P50 P59,67,68 P69 P70 All All	MAY/29/2014
1.1	1. Modified the ordering information of MX68GL1G0G 2. Content correction	P71 P37	NOV/26/2015
1.2	1. Added a statement for product ordering information 2. Modified the ordering information of MX68GL1G0G 3. Updated tVR descriptions. 4. Description modifications.	P71 P67-68 P54-55	FEB/17/2017
1.3	1. Added "Macronix Proprietary" footnote. 2. Added part numbers of with Fast Speed under Vcc 3.0V to 3.6V condition 3. Format modification.	All P71-72 P73-74	JUL/05/2018
1.4	1. Added PAGE BUFFER SRAM in the BLOCK DIAGRAM. 2. Revised AC CHARACTERISTICS. 3. Updated the maximum Sector erase operation value and the descriptions of Tghwl and Tghel parameters. 4. Revised Figure 18. COMMAND WRITE TIMING WAVEFORM (WE# CONTROLLED) and Figure 19. COMMAND WRITE TIMING WAVEFORM (CE# CONTROLLED). 5. Added the maximum Total Write Buffer Time value. 6. Updated the ordering information.	P10-11 P52 P53 P54-55 P69 P71	MAY/29/2020



MACRONIX
INTERNATIONAL CO., LTD.

MX29GL512G
MX68GL1G0G

Except for customized products which have been expressly identified in the applicable agreement, Macronix's products are designed, developed, and/or manufactured for ordinary business, industrial, personal, and/or household applications only, and not for use in any applications which may, directly or indirectly, cause death, personal injury, or severe property damages. In the event Macronix products are used in contradicted to their target usage above, the buyer shall take any and all actions to ensure said Macronix's product qualified for its actual use in accordance with the applicable laws and regulations; and Macronix as well as it's suppliers and/or distributors shall be released from any and all liability arisen therefrom.

Copyright© Macronix International Co., Ltd. 2012-2020. All rights reserved, including the trademarks and tradename thereof, such as Macronix, MXIC, MXIC Logo, MX Logo, Integrated Solutions Provider, Nbit, Macronix NBit, HybridNVM, HybridFlash, HybridXFlash, XtraROM, KH Logo, BE-SONOS, KSMC, Kingtech, MXSMIO, Macronix vEE, RichBook, Rich TV, OctaBus, FitCAM, ArmorFlash. The names and brands of third party referred thereto (if any) are for identification purposes only.

For the contact and order information, please visit Macronix's Web site at: <http://www.macronix.com>

MACRONIX INTERNATIONAL CO., LTD. reserves the right to change product and specifications without notice.