

Contents

- 1 Block diagram 3**
- 2 Electrical data 4**
 - 2.1 Absolute maximum ratings 4
 - 2.2 Thermal data 4
 - 2.3 Recommended operating conditions 4
- 3 Pin connection 5**
- 4 Electrical characteristics 6**
 - 4.1 AC operation 6
 - 4.2 DC operation 6
 - 4.3 Timing diagram 7
- 5 Bootstrap driver 8**
 - C_{BOOT} selection and charging 8
- 6 Typical characteristic 10**
- 7 Package information 12**
 - 7.1 DIP-8 package information 12
 - 7.2 SO-8 package information 14
- 8 Order codes 16**
- 9 Revision history 16**

1 Block diagram

Figure 1. Block diagram

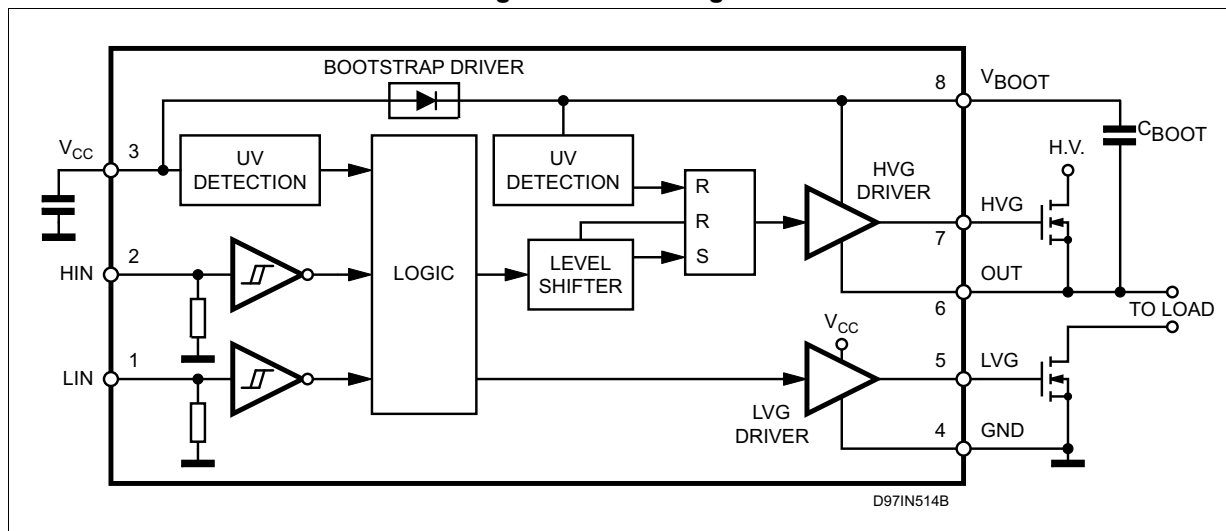

2 Electrical data

2.1 Absolute maximum ratings

Table 1. Absolute maximum ratings

Symbol	Parameter	Value	Unit
V _{OUT}	Output voltage	-3 to V _{BOOT} -18	V
V _{CC}	Supply voltage	- 0.3 to +18	V
V _{BOOT}	Floating supply voltage	-1 to 618	V
V _{hvg}	High-side gate output voltage	-1 to V _{BOOT}	V
V _{lvg}	Low-side gate output voltage	-0.3 to V _{CC} +0.3	V
V _i	Logic input voltage	-0.3 to V _{CC} +0.3	V
dV _{OUT} /dt	Allowed output slew rate	50	V/ns
P _{tot}	Total power dissipation (T _J = 85 °C)	750	mW
T _J	Junction temperature	150	°C
T _s	Storage temperature	-50 to 150	°C
ESD	Human body model	2	kV

2.2 Thermal data

Table 2. Thermal data

Symbol	Parameter	SO-8	DIP-8	Unit
R _{th(JA)}	Thermal resistance junction to ambient	150	100	°C/W

2.3 Recommended operating conditions

Table 3. Recommended operating conditions

Symbol	Pin	Parameter	Test condition	Min.	Typ.	Max.	Unit
V _{OUT}	6	Output voltage		(1)		580	V
V _{BS} ⁽²⁾	8	Floating supply voltage		(1)		17	V
f _{sw}		Switching frequency	HVG, LVG load C _L = 1 nF			400	kHz
V _{CC}	3	Supply voltage				17	V
T _J		Junction temperature		-45		125	°C

1. If the condition V_{BOOT} - V_{OUT} < 18 V is guaranteed, V_{OUT} can range from -3 to 580 V.

2. V_{BS} = V_{BOOT} - V_{OUT}.

3 Pin connection

Figure 2. Pin connection (top view)

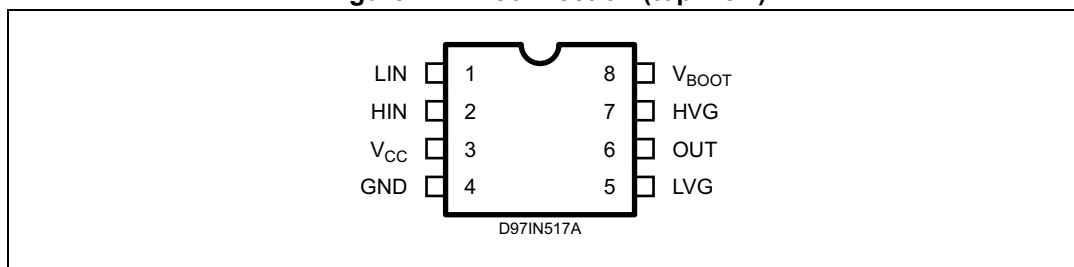

Table 4. Pin description

No.	Pin	Type	Function
1	LIN	I	Low-side driver logic input
2	HIN	I	High-side driver logic input
3	V _{CC}	P	Low voltage power supply
4	GND	P	Ground
5	LVG ⁽¹⁾	O	Low-side driver output
6	OUT	P	High-side driver floating reference
7	HVG ⁽¹⁾	O	High-side driver output
8	V _{BOOT}	P	Bootstrap supply voltage

1. The circuit guarantees 0.3 V maximum on the pin (at $I_{sink} = 10$ mA). This allows to omit the “bleeder” resistor connected between the gate and the source of the external MOSFET normally used to hold the pin low.

4 Electrical characteristics

4.1 AC operation

Table 5. AC operation electrical characteristics ($V_{CC} = 15\text{ V}$; $T_J = 25\text{ }^\circ\text{C}$)

Symbol	Pin	Parameter	Test condition	Min.	Typ.	Max.	Unit
t_{on}	1 vs. 5 2 vs. 7	High/low-side driver turn-on propagation delay	$V_{OUT} = 0\text{ V}$		110		ns
t_{off}	1 vs. 5 2 vs. 7	High/low-side driver turn-off propagation delay	$V_{OUT} = 0\text{ V}$		105		ns
t_r	5, 7	Rise time	$C_L = 1000\text{ pF}$		50		ns
t_f	5, 7	Fall time	$C_L = 1000\text{ pF}$		30		ns

4.2 DC operation

Table 6. DC operation electrical characteristics ($V_{CC} = 15\text{ V}$; $T_J = 25\text{ }^\circ\text{C}$)

Symbol	Pin	Parameter	Test condition	Min.	Typ.	Max.	Unit
Low supply voltage section							
V_{CC}	3	Supply voltage				17	V
V_{CCth1}		V_{CC} UV turn-on threshold		9.1	9.6	10.1	V
V_{CCth2}		V_{CC} UV turn-off threshold		7.9	8.3	8.8	V
V_{CChys}		V_{CC} UV hysteresis			1.3		V
I_{QCCU}		Undervoltage quiescent supply current	$V_{CC} \leq 9\text{ V}$		150	220	μA
I_{QCC}		Quiescent current	$V_{IN} = 15\text{ V}$		250	320	μA
R_{dson}		Bootstrap driver on resistance ⁽¹⁾	$V_{CC} \geq 12.5\text{ V}$		125		Ω
Bootstrapped supply voltage section							
V_{BS}	8	Bootstrap supply voltage				17	V
V_{BSth1}		V_{BS} UV turn-on threshold		8.5	9.5	10.5	V
V_{BSth2}		V_{BS} UV turn-off threshold		7.2	8.2	9.2	V
V_{BSHys}		V_{BS} UV hysteresis			1.3		V
I_{QBS}		V_{BS} quiescent current	HVG ON			200	μA
I_{LK}		High voltage leakage current	$V_{hvg} = V_{OUT} = V_{BOOT} = 600\text{ V}$			10	μA
High/low-side driver							
I_{so}	5, 7	Source short-circuit current	$V_{IN} = V_{ih}$ ($t_p < 10\text{ }\mu\text{s}$)	300	400		mA
I_{si}		Sink short-circuit current	$V_{IN} = V_{il}$ ($t_p < 10\text{ }\mu\text{s}$)	450	650		mA

Table 6. DC operation electrical characteristics (V_{CC} = 15 V; T_J = 25 °C) (continued)

Symbol	Pin	Parameter	Test condition	Min.	Typ.	Max.	Unit
Logic inputs							
V _{il}	1, 2	Low level logic threshold voltage				1.5	V
V _{ih}		High level logic threshold voltage		3.6			V
I _{ih}	1, 2	High level logic input current	V _{IN} = 15 V		50	70	μA
I _{il}		Low level logic input current	V _{IN} = 0 V			1	μA

1. R_{DS(on)} is tested in the following way:

$$R_{DS(on)} = \frac{(V_{CC} - V_{BOOT1}) - (V_{CC} - V_{BOOT2})}{I_1(V_{CC}, V_{BOOT1}) - I_2(V_{CC}, V_{BOOT2})}$$

where I₁ is pin 8 current when V_{BOOT} = V_{BOOT1}, I₂ when V_{BOOT} = V_{BOOT2}.

4.3 Timing diagram

Figure 3. Input/output timing diagram

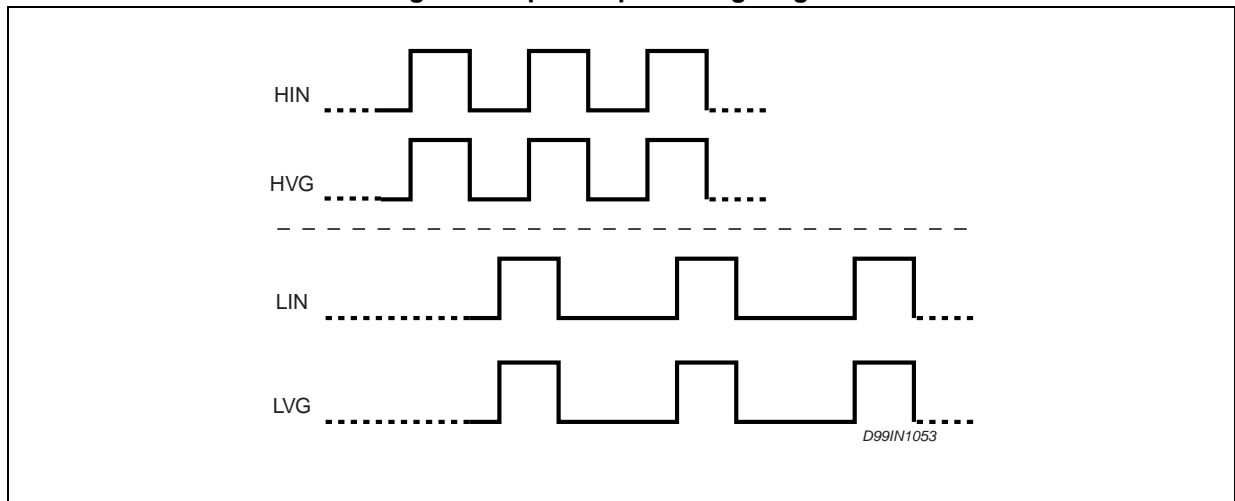

5 Bootstrap driver

A bootstrap circuitry is needed to supply the high voltage section. This function is normally accomplished by a high voltage fast recovery diode (*Figure 4 a*). In the L6385E device a patented integrated structure replaces the external diode. It is realized by a high voltage DMOS, driven synchronously with the low-side driver (LVG), with a diode in series, as shown in *Figure 4 b*. An internal charge pump (*Figure 4 b*) provides the DMOS driving voltage. The diode connected in series to the DMOS has been added to avoid undesirable turn-on.

C_{BOOT} selection and charging

To choose the proper C_{BOOT} value, the external MOSFET can be seen as an equivalent capacitor. This capacitor C_{EXT} is related to the MOSFET total gate charge:

Equation 1

$$C_{EXT} = \frac{Q_{gate}}{V_{gate}}$$

The ratio between the capacitors C_{EXT} and C_{BOOT} is proportional to the cyclical voltage loss. It has to be:

$$C_{BOOT} \gg C_{EXT}$$

E.g.: if Q_{gate} is 30nC and V_{gate} is 10V, C_{EXT} is 3nF. With $C_{BOOT} = 100$ nF the drop would be 300 mV.

If HVG has to be supplied for a long time, the C_{BOOT} selection has to take into account also the leakage losses.

E.g.: HVG steady state consumption is lower than 200 μ A, so if HVG T_{ON} is 5 ms, C_{BOOT} has to supply a maximum of 1 μ C to C_{EXT} . This charge on a 1mF capacitor means a voltage drop of 1 V.

The internal bootstrap driver gives great advantages: the external fast recovery diode can be avoided (it usually has a great leakage current).

This structure can work only if V_{OUT} is close to GND (or lower) and in the meanwhile the LVG is on. The charging time (T_{charge}) of the C_{BOOT} is the time in which both conditions are fulfilled and it has to be long enough to charge the capacitor.

The bootstrap driver introduces a voltage drop due to the DMOS R_{DSON} (typical value: 125 Ω). At low frequency this drop can be neglected. Anyway increasing the frequency it must be taken in to account.

The following equation is useful to compute the drop on the bootstrap DMOS:

Equation 2

$$V_{drop} = I_{charge} R_{dson} \rightarrow V_{drop} = \frac{Q_{gate}}{T_{charge}} R_{dson}$$

where Q_{gate} is the gate charge of the external power MOSFET, R_{dson} is the on resistance of the bootstrap DMOS, and T_{charge} is the charging time of the bootstrap capacitor.

For example: using a power MOSFET with a total gate charge of 30 nC the drop on the bootstrap DMOS is about 1 V, if the T_{charge} is 5 ms. In fact:

Equation 3

$$V_{\text{drop}} = \frac{30\text{nC}}{5\mu\text{s}} \cdot 125\Omega \sim 0.8\text{V}$$

V_{drop} has to be taken into account when the voltage drop on C_{BOOT} is calculated: if this drop is too high, or the circuit topology doesn't allow a sufficient charging time, an external diode can be used.

Figure 4. Bootstrap driver

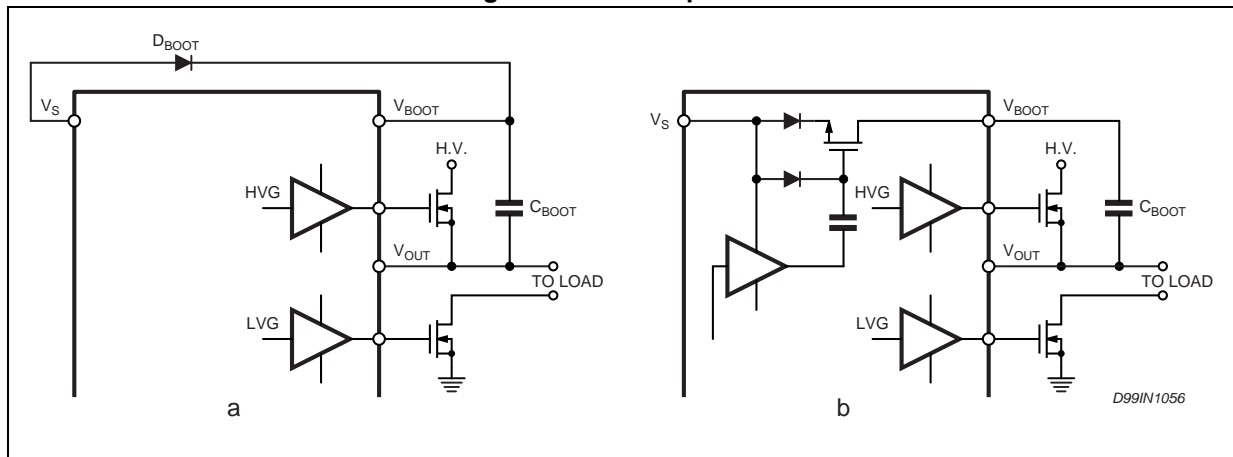

6 Typical characteristic

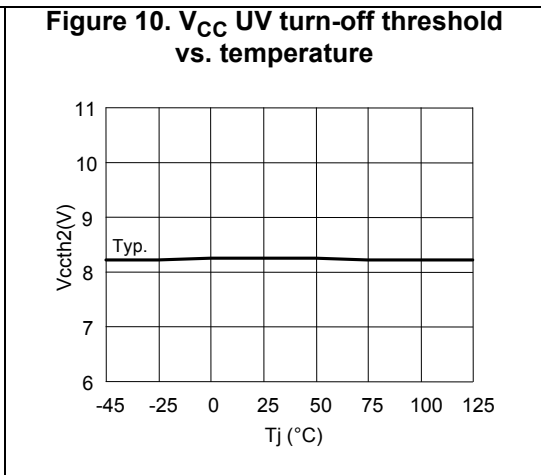
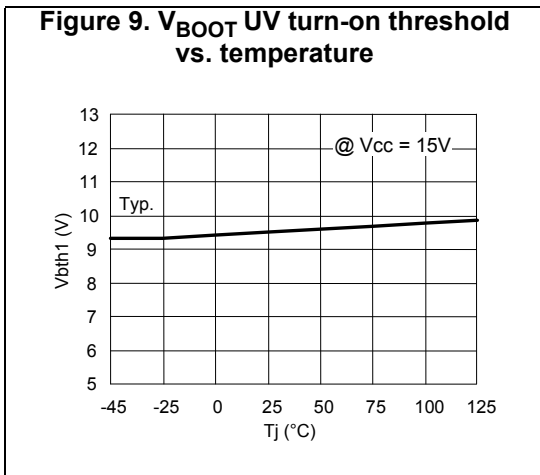
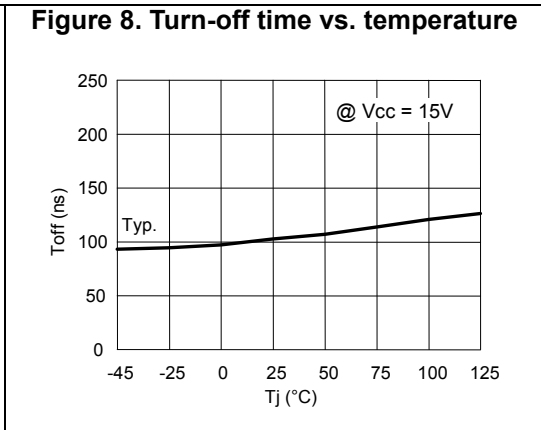
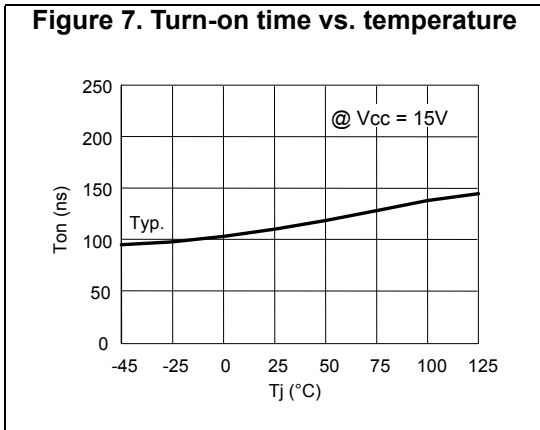
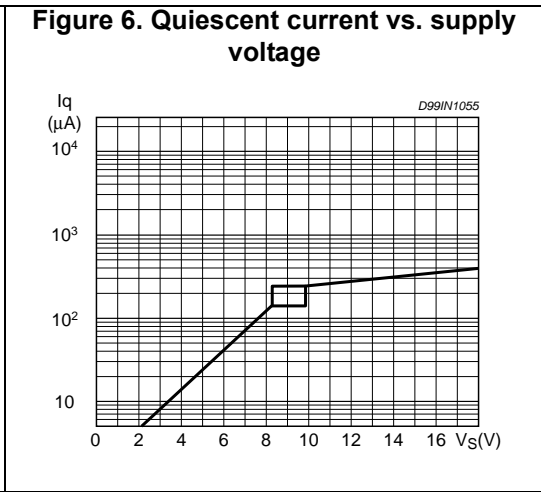
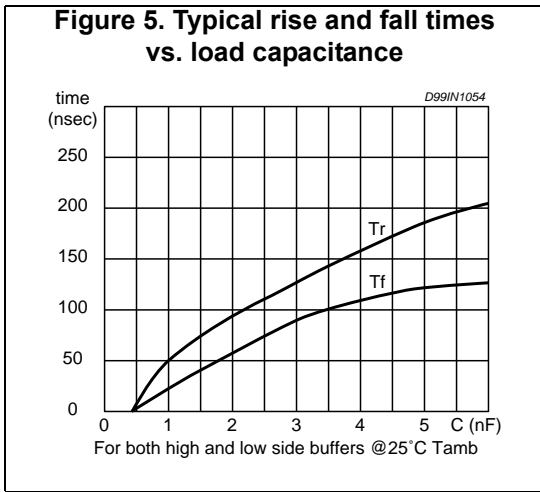

Figure 11. V_{BOOT} UV turn-off threshold vs. temperature

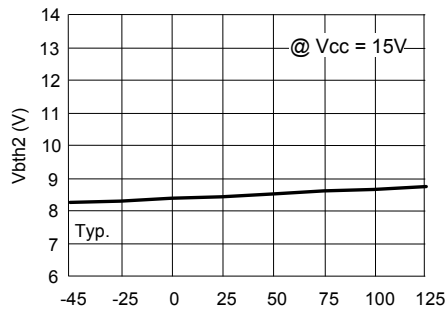

Figure 12. Output source current vs. temperature

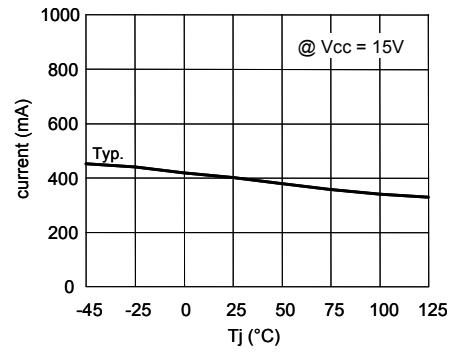

Figure 13. V_{CC} UV turn-on threshold vs. temperature

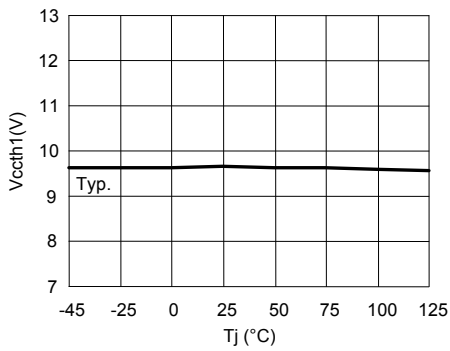
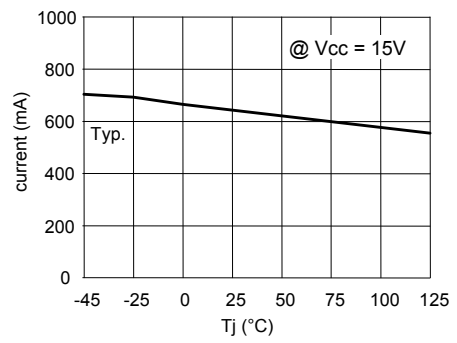

Figure 14. Output sink current vs. temperature



7 Package information

In order to meet environmental requirements, ST offers these devices in different grades of ECOPACK[®] packages, depending on their level of environmental compliance. ECOPACK specifications, grade definitions and product status are available at: www.st.com. ECOPACK is an ST trademark.

7.1 DIP-8 package information

Figure 15. DIP-8 package outline

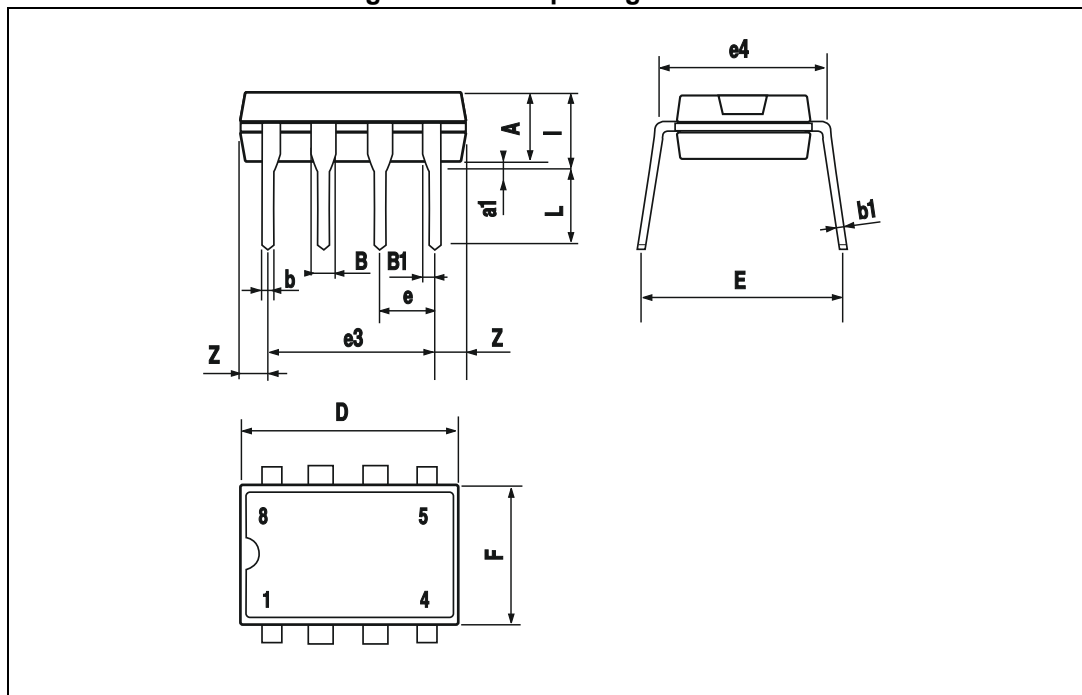

Table 7. DIP-8 package mechanical data

Symbol	Dimensions (mm)			Dimensions (inch)		
	Min.	Typ.	Max.	Min.	Typ.	Max.
A		3.32			0.131	
a1	0.51			0.020		
B	1.15		1.65	0.045		0.065
b	0.356		0.55	0.014		0.022
b1	0.204		0.304	0.008		0.012
D			10.92			0.430
E	7.95		9.75	0.313		0.384
e		2.54			0.100	
e3		7.62			0.300	
e4		7.62			0.300	
F			6.6			0.260
I			5.08			0.200
L	3.18		3.81	0.125		0.150
Z			1.52			0.060

7.2 SO-8 package information

Figure 16. SO-8 package outline

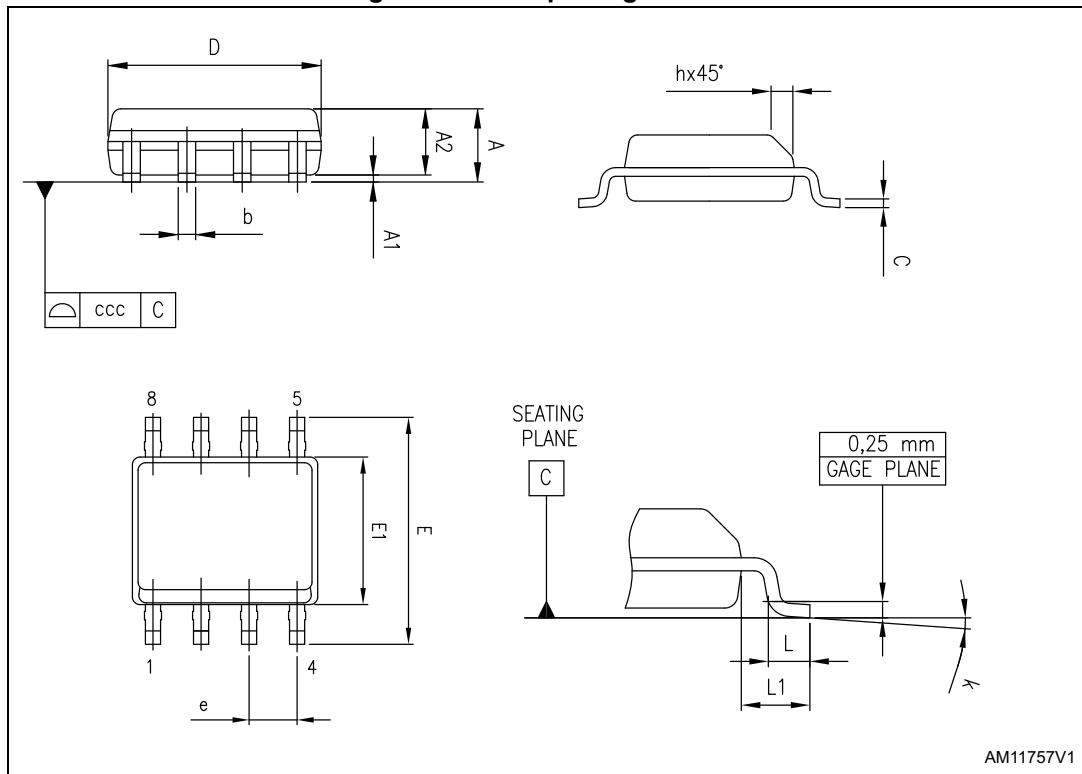

Table 8. SO-8 package mechanical data

Symbol	Dimensions (mm)			Dimensions (inch)		
	Min.	Typ.	Max.	Min.	Typ.	Max.
A			1.750			0.0689
A1	0.100		0.250	0.0039		0.0098
A2	1.250			0.0492		
b	0.280		0.480	0.0110		0.0189
c	0.170		0.230	0.0067		0.0091
D ⁽¹⁾	4.800	4.900	5.000	0.1890	0.1929	0.1969
E	5.800	6.000	6.200	0.2283	0.2362	0.2441
E1 ⁽²⁾	3.800	3.900	4.000	0.1496	0.1535	0.1575
e		1.270			0.0500	
h	0.250		0.500	0.0098		0.0197
L	0.400		1.270	0.0157		0.0500
L1		1.040			0.0409	
k	0°		8°	0°		8°
ccc			0.10			0.0039

1. Dimension "D" does not include mold flash, protrusions or gate burrs. Mold flash, protrusions or gate burrs shall not exceed 0.15 mm in total (both sides).
2. Dimension "E1" does not include interlead flash or protrusions. Interlead flash or protrusions shall not exceed 0.25 mm per side.

8 Order codes

Table 9. Order codes

Order code	Package	Packaging
L6385E	DIP-8	Tube
L6385ED	SO-8	Tube
L6385ED013TR	SO-8	Tape and reel

9 Revision history

Table 10. Document revision history

Date	Revision	Changes
02-Oct-2007	1	First release
19-Jun-2014	2	<p>Added Section : Applications on page 1.</p> <p>Updated Section : Description on page 1 (replaced by new description).</p> <p>Updated Table 1: Device summary on page 1 (moved from page 15 to page 1, renamed title of Table 1).</p> <p>Updated Figure 1: Block diagram on page 3 (moved from page 1 to page 3, added Section 1: Block diagram on page 3).</p> <p>Updated Section 2.1: Absolute maximum ratings on page 4 (removed note below Table 2: Absolute maximum ratings).</p> <p>Updated Table 5: Pin description on page 5 (updated "Pin" and "Type").</p> <p>Updated Section : C_{BOOT} selection and charging on page 8 (updated values of "E.g.: HVG").</p> <p>Numbered Equation 1 on page 8, Equation 2 on page 8 and Equation 3 on page 9.</p> <p>Updated Section 7: Package information on page 12 [updated/added titles, reversed order of Figure 15 and Table 8, Figure 16 and Table 9 (numbered tables), removed 3D package figures, minor modifications].</p> <p>Minor modifications throughout document.</p>
01-Dec-2014	3	<p>Updated Section : Description on page 1.</p> <p>Updated Table 6 on page 6 (corrected typo in units of "I_{so}" and "I_{si}" parameters).</p>
23-Sep-2015	4	<p>Updated Table 1 on page 4 (added ESD parameter and value).</p> <p>Updated note 1. below Table 6 on page 6 (replaced V_{CBOOTx} by V_{BOOTx}).</p> <p>Moved Table 9 on page 16 (moved from page 1 to page 16, added/updated titles).</p> <p>Minor modifications throughout document.</p>

IMPORTANT NOTICE – PLEASE READ CAREFULLY

STMicroelectronics NV and its subsidiaries (“ST”) reserve the right to make changes, corrections, enhancements, modifications, and improvements to ST products and/or to this document at any time without notice. Purchasers should obtain the latest relevant information on ST products before placing orders. ST products are sold pursuant to ST’s terms and conditions of sale in place at the time of order acknowledgement.

Purchasers are solely responsible for the choice, selection, and use of ST products and ST assumes no liability for application assistance or the design of Purchasers’ products.

No license, express or implied, to any intellectual property right is granted by ST herein.

Resale of ST products with provisions different from the information set forth herein shall void any warranty granted by ST for such product.

ST and the ST logo are trademarks of ST. All other product or service names are the property of their respective owners.

Information in this document supersedes and replaces information previously supplied in any prior versions of this document.

© 2015 STMicroelectronics – All rights reserved

