

### ABSOLUTE MAXIMUM RATINGS

PARAMETERS	LIMITS	UNITS
+15V Supply (Pin 9)	0 to +16	Volts
-15V Supply (Pin 8)	0 to -16	Volts
+5V Supply (Pins 10, 14)	0 to +6	Volts
-5V Supply (Pin 11)	0 to -6	Volts
Digital Input (Pin 16)	-0.3 to +V <sub>DD</sub> +0.3	Volts
Analog Input (Pin 1)	±15	Volts
Lead Temperature (10 seconds)	+300	°C

### PHYSICAL/ENVIRONMENTAL

PARAMETERS	MIN.	TYP.	MAX.	UNITS
<b>Operating Temp. Range, Case</b>				
ADS-937MC	0	—	+70	°C
ADS-937MM/883	-55	—	+125	°C
<b>Thermal Impedance</b>				
θ <sub>jc</sub>	—	5	—	°C/Watt
θ <sub>ca</sub>	—	22	—	°C/Watt
<b>Storage Temperature Range</b>				
	-65	—	+150	°C
<b>Package Type</b>				
32-pin, side-brazed, metal-sealed, ceramic TDIP				
<b>Weight</b>				
0.56 ounces (16 grams)				

### FUNCTIONAL SPECIFICATIONS

(T<sub>A</sub> = +25°C, ±V<sub>CC</sub> = ±15V, +V<sub>DD</sub> = ±5V, 1MHz sampling rate, and a minimum 1 minute warm-up ① unless otherwise specified.)

PARAMETERS	+25°C			0 to +70°C			-55 to +125°C			UNITS
	MIN.	TYP.	MAX.	MIN.	TYP.	MAX.	MIN.	TYP.	MAX.	
<b>ANALOG INPUT</b>										
Input Voltage Range ②										
Bipolar	—	±5	—	—	±5	—	—	±5	—	Volts
Unipolar	—	0 to -10	—	—	0 to -10	—	—	0 to -10	—	Volts
Input Resistance	—	1	—	—	1	—	—	1	—	kΩ
Input Capacitance	—	7	15	—	7	15	—	7	15	pF
<b>DIGITAL INPUTS</b>										
Logic Levels										
Logic "1"	+2.0	—	—	+2.0	—	—	+2.0	—	—	Volts
Logic "0"	—	—	+0.8	—	—	+0.8	—	—	+0.8	Volts
Logic Loading "1"	—	—	+20	—	—	+20	—	—	+20	μA
Logic Loading "0"	—	—	-20	—	—	-20	—	—	-20	μA
Start Convert Positive Pulse Width ③	20	500	—	20	500	—	20	500	—	ns
<b>STATIC PERFORMANCE</b>										
Resolution	—	16	—	—	16	—	—	16	—	Bits
Integral Nonlinearity	—	±0.75	—	—	±1.5	—	—	±2	—	LSB
Differential Nonlinearity (f <sub>in</sub> = 10kHz)	-0.95	±0.5	+1	-0.95	±0.5	+1	-0.95	±0.5	+1.5	LSB
Full Scale Absolute Accuracy	—	±0.1	±0.25	—	±0.2	±0.4	—	±0.25	±0.5	%FSR
Bipolar Zero Error (Tech Note 2)	—	±0.1	±0.15	—	±0.1	±0.25	—	±0.15	±0.5	%FSR
Bipolar Offset Error (Tech Note 2)	—	±0.1	±0.2	—	±0.15	±0.3	—	±0.2	±0.5	%FSR
Gain Error (Tech Note 2)	—	±0.1	±0.3	—	±0.25	±0.5	—	±0.4	±0.7	%
Unipolar Offset Error (Tech Note 2)	—	±0.1	±0.15	—	±0.1	±0.25	—	±0.15	±0.5	%FSR
No Missing Codes (f <sub>in</sub> = 10kHz)	16	—	—	16	—	—	16	—	—	Bits
<b>DYNAMIC PERFORMANCE</b>										
Peak Harmonics (-0.5dB)										
dc to 100kHz	—	-90	-84	—	-90	-84	—	-88	-83	dB
100kHz to 500kHz	—	-88	-81	—	-88	-81	—	-87	-80	dB
Total Harmonic Distortion (-0.5dB)										
dc to 100kHz	—	-87	-82	—	-87	-82	—	-86	-81	dB
100kHz to 500kHz	—	-86	-81	—	-86	-81	—	-85	-80	dB
Signal-to-Noise Ratio										
(w/o distortion, -0.5dB)										
dc to 100kHz	85	88	—	85	88	—	84	87	—	dB
100kHz to 500kHz	84	87	—	84	87	—	83	87	—	dB
Signal-to-Noise Ratio ④										
(& distortion, -0.5dB)										
dc to 100kHz	81	85	—	81	85	—	80	84	—	dB
100kHz to 500kHz	80	84	—	80	84	—	78	83	—	dB
Noise	—	110	—	—	110	—	—	110	—	μVrms
Two-Tone Intermodulation										
Distortion (f <sub>in</sub> = 100kHz, 240kHz, f <sub>s</sub> = 1MHz, -0.5dB)	—	-85	—	—	-85	—	—	-85	—	dB
Input Bandwidth (-3dB)										
Small Signal (-20dB input)	—	4.5	—	—	4.5	—	—	4.5	—	MHz
Large Signal (-0.5dB input)	—	4	—	—	4	—	—	4	—	MHz
Feedthrough Rejection (f <sub>in</sub> = 500kHz)	—	84	—	—	84	—	—	84	—	dB
Slew Rate	—	±33	—	—	±33	—	—	±33	—	V/μs
Aperture Delay Time	—	+20	—	—	+20	—	—	+20	—	ns
Aperture Uncertainty	—	5	—	—	5	—	—	5	—	ps rms
S/H Acquisition Time										
( to ±0.003%FSR, 10V step)	—	260	300	—	260	300	—	260	300	ns
Overvoltage Recovery Time ⑤	—	500	1000	—	500	1000	—	500	1000	ns
A/D Conversion Rate	1	—	—	1	—	—	1	—	—	MHz

	+25°C			0 TO +70°C			-55 TO +125°C			UNITS
	MIN.	TYP.	MAX.	MIN.	TYP.	MAX.	MIN.	TYP.	MAX.	
<b>ANALOG OUTPUT</b>										
Internal Reference Voltage	+4.95	+5.0	+5.05	+4.95	+5.0	+5.05	+4.95	+5.0	+5.05	Volts
Drift	—	±30	—	—	±30	—	—	±30	—	ppm/°C
External Current	—	1	—	—	1	—	—	1	—	mA
<b>DIGITAL OUTPUTS</b>										
Logic Levels										
Logic "1"	+2.4	—	—	+2.4	—	—	+2.4	—	—	Volts
Logic "0"	—	—	+0.4	—	—	+0.4	—	—	+0.4	Volts
Logic Loading "1"	—	—	-4	—	—	-4	—	—	-4	mA
Logic Loading "0"	—	—	+4	—	—	+4	—	—	+4	mA
Output Coding	(Offset) Binary / Complementary (Offset) Binary									
<b>POWER REQUIREMENTS</b>										
Power Supply Ranges										
+15V Supply	+14.5	+15.0	+15.5	+14.5	+15.0	+15.5	+14.5	+15.0	+15.5	Volts
-15V Supply	-14.5	-15.0	-15.5	-14.5	-15.0	-15.5	-14.5	-15.0	-15.5	Volts
+5V Supply	+4.75	+5.0	+5.25	+4.75	+5.0	+5.25	+4.75	+5.0	+5.25	Volts
-5V Supply	-4.75	-5.0	-5.25	-4.75	-5.0	-5.25	-4.75	-5.0	-5.25	Volts
Power Supply Currents										
+15V Supply	—	+7	+9	—	+7	+9	—	+7	+9	mA
-15V Supply	—	-8	-10	—	-8	-10	—	-8	-10	mA
+5V Supply	—	+133	+145	—	+133	+145	—	+133	+145	mA
-5V Supply	—	-72	-80	—	-72	-80	—	-72	-80	mA
Power Dissipation	—	1.25	1.35	—	1.25	1.35	—	1.25	1.35	Watts
Power Supply Rejection	—	—	±0.01	—	—	±0.01	—	—	±0.01	%FSR/%V

### Footnotes:

- ① All power supplies must be on before applying a start convert pulse. All supplies and the clock (START CONVERT) must be present during warm-up periods. The device must be continuously converting during this time.
- ② Contact DATEL for other input voltage ranges.
- ③ A 1MHz clock with a 500nsec positive pulse width (50% duty cycle) is used for all production testing. Any duty cycle may be used as long as a minimum positive pulse width of 20nsec is maintained. For applications requiring lower sampling rates, clock frequencies less than 1MHz may be used.

- ④ Effective bits is equal to:
 
$$\frac{(\text{SNR} + \text{Distortion}) - 1.76 + \left[ 20 \log \frac{\text{Full Scale Amplitude}}{\text{Actual Input Amplitude}} \right]}{6.02}$$
- ⑤ This is the time required before the A/D output data is valid once the analog input is back within the specified range.

### TECHNICAL NOTES

1. Obtaining fully specified performance from the ADS-937 requires careful attention to pc-card layout and power supply decoupling. The device's ground pins are not connected to each other internally. For optimal performance, tie all ground pins (2, 12 and 13) directly to a large analog ground plane beneath the package. The device's +5V supply pins are not connected to each other internally and should be connected to a clean analog +5V supply. Bypass all power supplies and the +5V REFERENCE OUTPUT (pin 5) to ground with 4.7µF tantalum capacitors in parallel with 0.1µF ceramic capacitors. Locate the bypass capacitors as close to the unit as possible. Tie a 47µF capacitor between COMPENSATION (pin 7) and ground (See figure 2).
2. The ADS-937 achieves its specified accuracies without the need for external calibration. If required, the device's small initial offset and gain errors can be reduced to zero using the adjustment circuitry shown in Figure 2. When using this circuitry, or any similar offset and gain calibration hardware, make adjustments following warm-up. To avoid interaction, always adjust offset before gain. Float pins 4 and 6 if not using offset and gain adjust circuits.
3. Applying a start convert pulse while a conversion is in progress (EOC = logic "1") will initiate a new and inaccurate conversion cycle. Data for the interrupted and subsequent conversions will be invalid.

### THERMAL REQUIREMENTS

All DATEL sampling A/D converters are fully characterized and specified over operating temperature (case) ranges of 0 to +70°C and -55 to +125°C. All room-temperature (TA = +25°C) production testing is performed without the use of heat sinks or forced-air cooling. Thermal impedance figures for each device are listed in their respective specification tables. These devices do not normally require heat sinks, however, standard precautionary design and layout procedures should be used to ensure devices do not overheat. The ground and power planes beneath the package, as well as all pcb signal runs to and from the device, should be as heavy as possible to help conduct heat away from the package. Electrically-insulating, thermally-conductive "pads" may be installed underneath the package. Devices should be soldered to boards rather than "socketed", and of course, minimal air flow over the surface can greatly help reduce the package temperature.

### CALIBRATION PROCEDURE

Connect the converter per Table 1 for the appropriate input voltage range. Any offset/gain calibration procedures should not be implemented until the device is fully warmed up. To avoid interaction, adjust offset before gain. The ranges of adjustment for the circuits in Figure 2 are guaranteed to compensate for the ADS-937's initial accuracy errors and may not be able to compensate for additional system errors.

A/D converters are calibrated by positioning their digital outputs exactly on the transition point between two adjacent digital output codes. This is accomplished by connecting LED's to the digital outputs and performing adjustments until certain LED's "flicker" equally between on and off. Other approaches employ digital comparators or microcontrollers to detect when the outputs change from one code to the next.

For the ADS-937, offset adjusting is normally accomplished when the analog input is 0 minus 1/2LSB (-76.3µV). See Table 2 for the proper bipolar and unipolar output coding.

Gain adjusting is accomplished when the analog input is at nominal full scale minus 1 1/2LSB's (-9.999771V for unipolar and -4.999771V for bipolar).

#### Zero/Offset Adjust Procedure

1. Apply a train of pulses to the START CONVERT input (pin 16) so that the converter is continuously converting.
2. For unipolar or bipolar zero/offset adjust, apply -76.3µV to the ANALOG INPUT (pin 1).

3. For a bipolar input - Adjust the offset potentiometer until the output code flickers equally between 1000 0000 0000 0000 and 0111 1111 1111 1111.

For a unipolar input - Adjust the offset potentiometer until all output bits are 0's and the LSB flickers between 0 and 1.

### GAIN ADJUST PROCEDURE

1. Apply -4.999771V to the ANALOG INPUT (pin 1) for bipolar gain adjust or apply -9.999771V to pin 1 for unipolar gain adjust.

2. For a unipolar input - Adjust the gain potentiometer until all output bits are 1's and the LSB flickers between 1 and 0.

For a bipolar input - Adjust the gain potentiometer until all output bits are 1's and the LSB flickers between 1 and 0.

3. To confirm proper operation of the device, vary the applied input voltage to obtain the output coding listed in Table 2.

Table 1. Setting Output Coding Selection (Pin 35)

INPUT VOLTAGE RANGE	INPUT PIN	TIE TOGETHER
±5V	Pin 1	Pins 2 and 3
0 to -10V	Pin 1	Pins 3 and 5

Table 2. Output Coding

COMPLEMENTARY BINARY		COMPLEMENTARY OFFSET BINARY			
UNIPOLAR SCALE	INPUT VOLTAGE 0 to -10V	OUTPUT CODING		INPUT RANGE ±5V	BIPOLAR SCALE
		MSB	LSB		
-FS +1 LSB	-9.999847	1111 1111 1111 1111	0000 0000 0000 0000	+4.999847	+FS -1 LSB
-7/8 FS	-8.750000	1110 0000 0000 0000	0001 1111 1111 1111	+3.750000	+3/4 FS
-3/4 FS	-7.500000	1100 0000 0000 0000	0011 1111 1111 1111	+2.500000	+1/2 FS
-1/2 FS	-5.000000	1000 0000 0000 0000	0111 1111 1111 1111	+0.000000	0
-1/4 FS	-2.500000	0100 0000 0000 0000	1011 1111 1111 1111	-2.500000	-1/2 FS
-1/8 FS	-1.250000	0010 0000 0000 0000	1101 1111 1111 1111	-3.750000	-3/4 FS
-1 LSB	-0.000153	0000 0000 0000 0001	1111 1111 1111 1110	-4.999847	-FS +1 LSB
0	0.000000	0000 0000 0000 0000	1111 1111 1111 1111	-5.000000	-FS

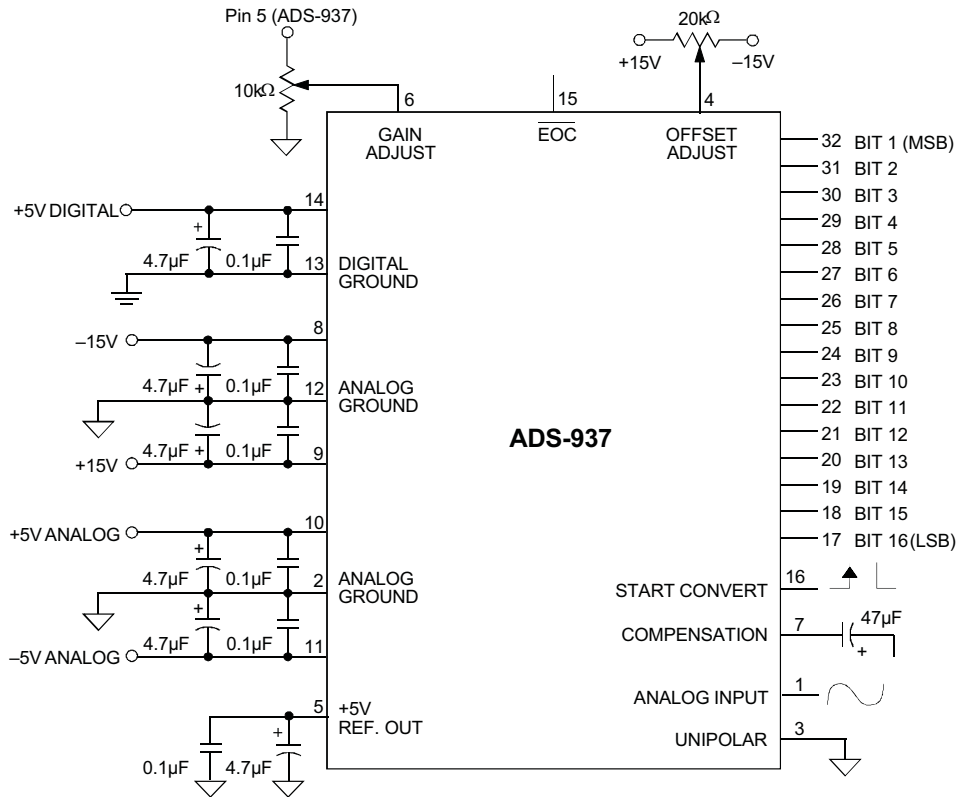
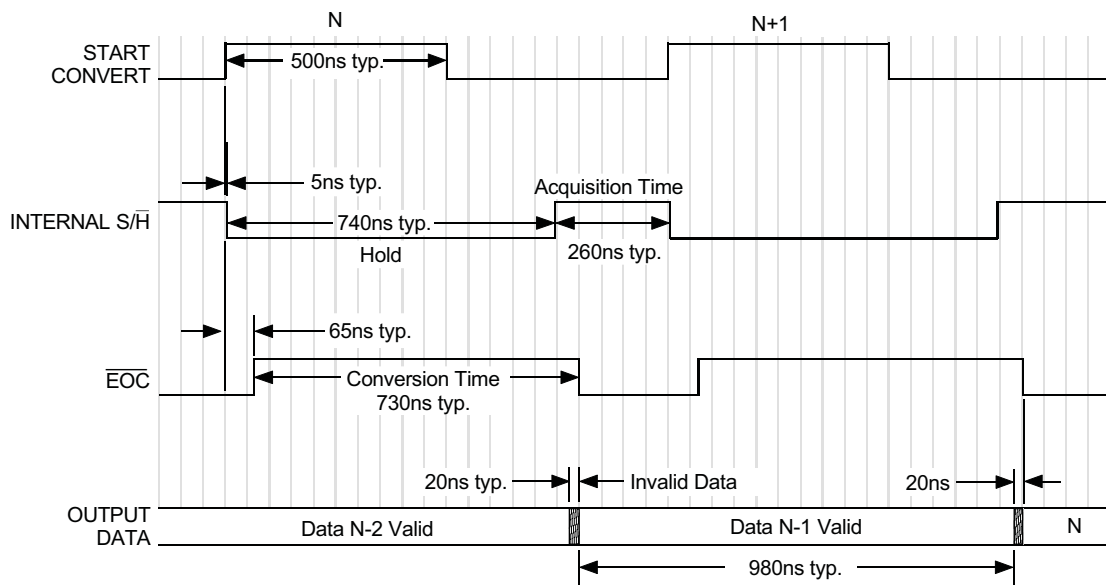

Figure 2. Typical ADS-937 Connection Diagram



Note: Scale is approximately 50ns per division. Sampling Rate = 1MHz.

Figure 3. ADS-937 Timing Diagram

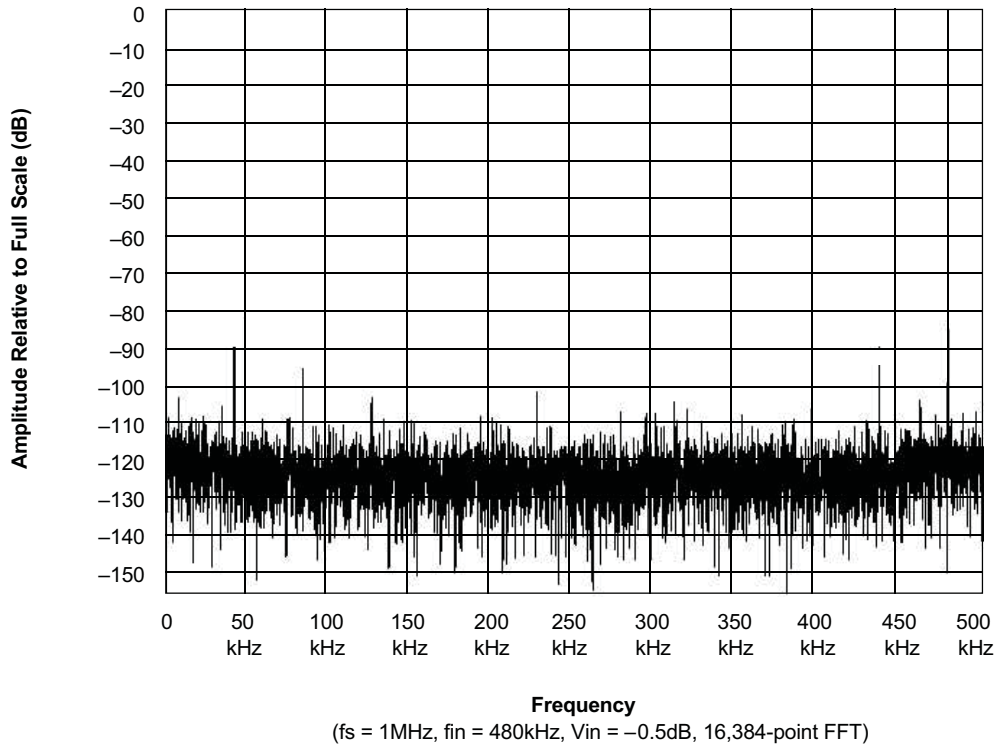

Figure 4. FFT Analysis of ADS-937

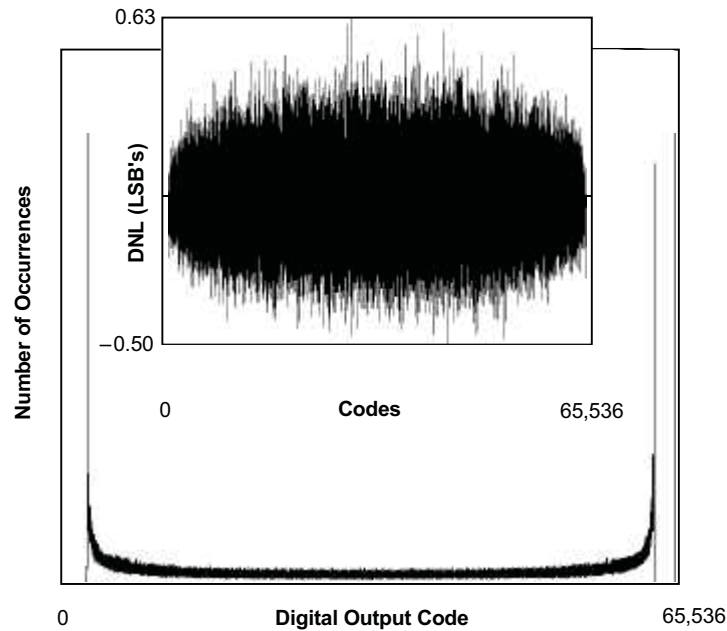

Figure 5. ADS-937 Histogram and Differential Nonlinearity

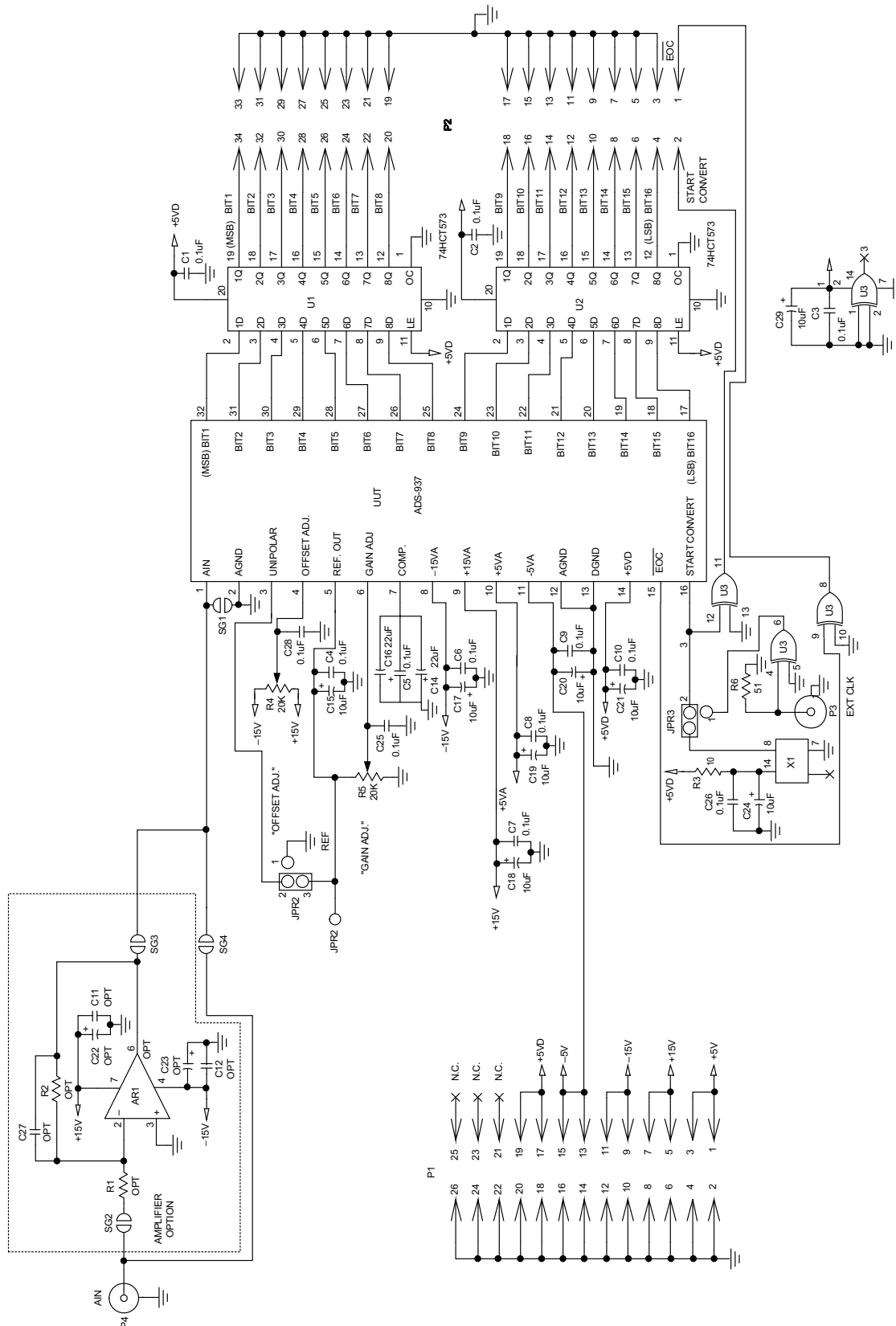
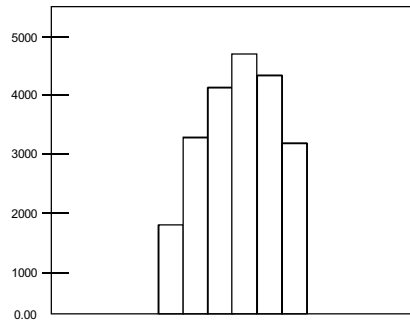

Figure 6. ADS-937 Evaluation Board.



This histogram represents the typical peak-to-peak noise (including quantization noise) associated with the ADS-937.

Digital Output Code

Figure 7. ADS-937 Grounded Input Histogram

**MECHANICAL DIMENSIONS INCHES (MM)**

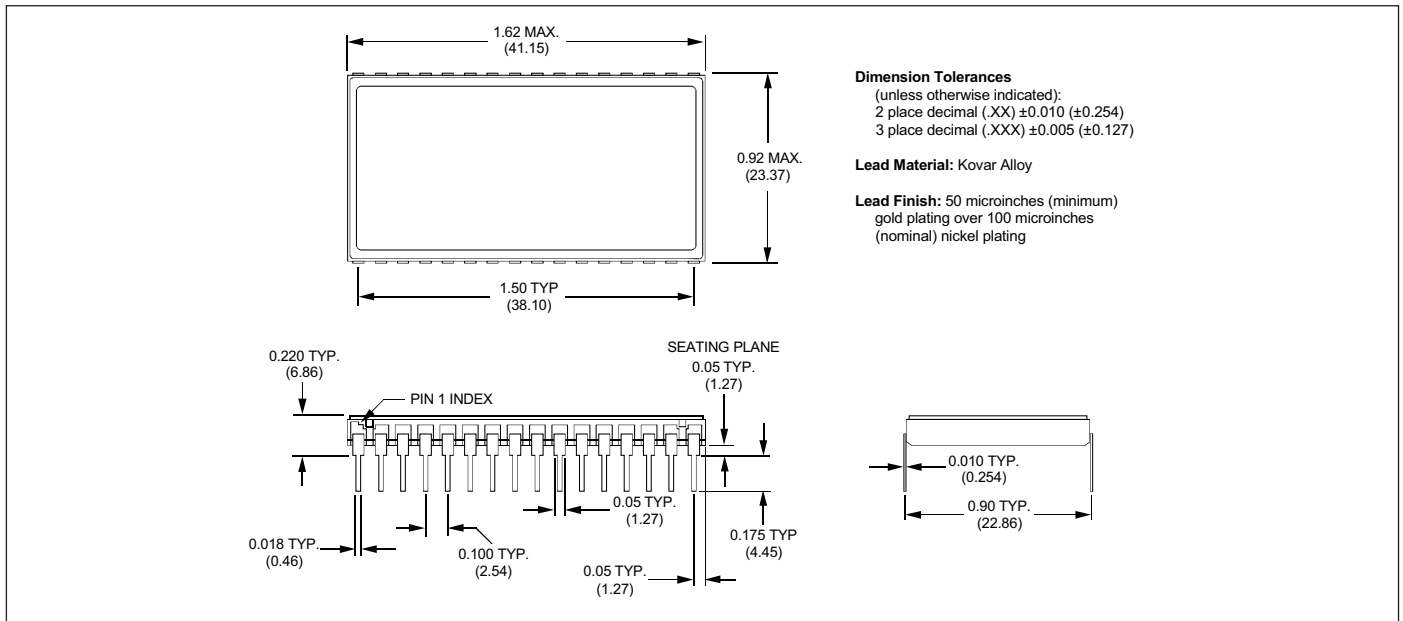

**ORDERING INFORMATION**

MODEL NUMBER	OPERATING TEMPERATURE RANGE	32-PIN PACKAGE	ACCESSORIES
ADS-937MC	0 to +70°C	TDIP	ADS-B937 Evaluation Board (without ADS937)
ADS-937MM	-55 to +125°C	TDIP	
ADS-937/883	-55 to +125°C	TDIP	

Receptacles for PC board mounting can be ordered through AMP, Inc., Part # 3-331272-8 (Component Lead Socket), 32 required. For availability of MIL-STD-883 product, contact DATEL.

DATEL is a registered trademark of  
**Murata Power Solutions, Inc.**  
11 Cabot Boulevard, Mansfield, MA 02048-1151 USA  
ITAR and ISO 9001/14001 REGISTERED

Murata Power Solutions, Inc. makes no representation that the use of its products in the circuits described herein, or the use of other technical information contained herein, will not infringe upon existing or future patent rights. The descriptions contained herein do not imply the granting of licenses to make, use, or sell equipment constructed in accordance therewith. Specifications are subject to change without notice.

© 2011 Murata Power Solutions, Inc.

www.datel.com • e-mail: help@datel.com