

Absolute Maximum Ratings

(All voltages referenced to GND.)

V _{DD} , HICLK, EN	-0.3V to +6V
T1, T2	-0.3V to +16.5V
T1, T2 Maximum Continuous Current	+1.75A
Continuous Power Dissipation (T _A = +70°C)	
TDFN (Multilayer Board)	
(derate 16.7mW/°C above +70°C)	1333.3mW

Operating Temperature Range	-40°C to +125°C
Junction Temperature	+150°C
Storage Temperature Range	-65°C to +150°C
Lead Temperature (soldering, 10s)	+300°C
Soldering Temperature (reflow)	+260°C

Stresses beyond those listed under "Absolute Maximum Ratings" may cause permanent damage to the device. These are stress ratings only, and functional operation of the device at these or any other conditions beyond those indicated in the operational sections of the specifications is not implied. Exposure to absolute maximum rating conditions for extended periods may affect device reliability.

Package Information

PACKAGE TYPE: 8 TDFN	
Package Code	T823+1
Outline Number	21-0174
Land Pattern Number	90-0091
THERMAL RESISTANCE, FOUR-LAYER BOARD	
Junction to Ambient (θ _{JA})	60°C/W
Junction to Case (θ _{JC})	11°C/W

For the latest package outline information and land patterns (footprints), go to www.maximintegrated.com/packages. Note that a "+", "#", or "-" in the package code indicates RoHS status only. Package drawings may show a different suffix character, but the drawing pertains to the package regardless of RoHS status.

Package thermal resistances were obtained using the method described in JEDEC specification JESD51-7, using a four-layer board. For detailed information on package thermal considerations, refer to www.maximintegrated.com/thermal-tutorial.

Electrical Characteristics

(V_{DD} = +3.0V to 5.5V, T_A = T_{MIN} to T_{MAX}, unless otherwise noted. Typical values at V_{DD} = +5.0V and T_A = +25°C.) (Note 1)

PARAMETER	SYMBOL	CONDITIONS	MIN	TYP	MAX	UNITS
DC CHARACTERISTICS						
Supply Voltage Range	V _{DD}		3.0		5.5	V
Supply Current	I _{DD}	V _{EN} = 0V, T1 and T2 not connected	V _{HICLK} = 0V	1.1	1.8	mA
			V _{HICLK} = V _{DD}	2.1	3.5	
Disable Supply Current	I _{DIS}	V _{EN} = V _{DD} , T1, T2, HICLK connected to GND or V _{DD} (Note 3)			5	µA
Driver Output Resistance	R _O	I _{OUT} = 500mA	V _{DD} = 3.0V	160	350	mΩ
			V _{DD} = 4.5V	145	300	
Undervoltage Lockout Threshold	V _{UVLO}	V _{DD} rising	2.6	2.75	2.9	V
Undervoltage Lockout Threshold Hysteresis	V _{UVLO_HYST}			250		mV
T1, T2 Leakage Current	I _{LKG}	V _{EN} = V _{DD} , T1, T2 = 0V or V _{DD}	-1		+1	µA

Electrical Characteristics (continued)

($V_{DD} = +3.0V$ to $5.5V$, $T_A = T_{MIN}$ to T_{MAX} , unless otherwise noted. Typical values at $V_{DD} = +5.0V$ and $T_A = +25^{\circ}C$.) (Note 1)

PARAMETER	SYMBOL	CONDITIONS	MIN	TYP	MAX	UNITS	
LOGIC SIGNALS (\overline{EN}, HICLK)							
Input Logic-High Voltage	V_{IH}		2			V	
Input Logic-Low Voltage	V_{IL}				0.8	V	
Input Leakage Current	I_{IL}	\overline{EN} , HICLK = 0V or 5.5V	-1		+1	μA	
AC CHARACTERISTICS							
Switching Frequency	f_{SW}	Figure 1	$V_{HICLK} = 0V$	237	250	263	kHz
			$V_{HICLK} = V_{DD}$	564	600	636	
T1, T2 Duty Cycle	D			50		%	
T1, T2 Slew Rate	t_{SLEW}	Figure 1		200		V/ μs	
Crossover Dead Time	t_{DEAD}	Figure 1		50		ns	
PROTECTION							
Thermal-Shutdown Threshold	T_{SHDN}			+160		$^{\circ}C$	
Thermal-Shutdown Hysteresis	T_{SHDN_HYS}			30		$^{\circ}C$	

Note 1: All units are 100% production tested at $T_A = +25^{\circ}C$. Specifications over temperature are guaranteed by design.

Note 2: Disable supply current includes output-switch-leakage currents.

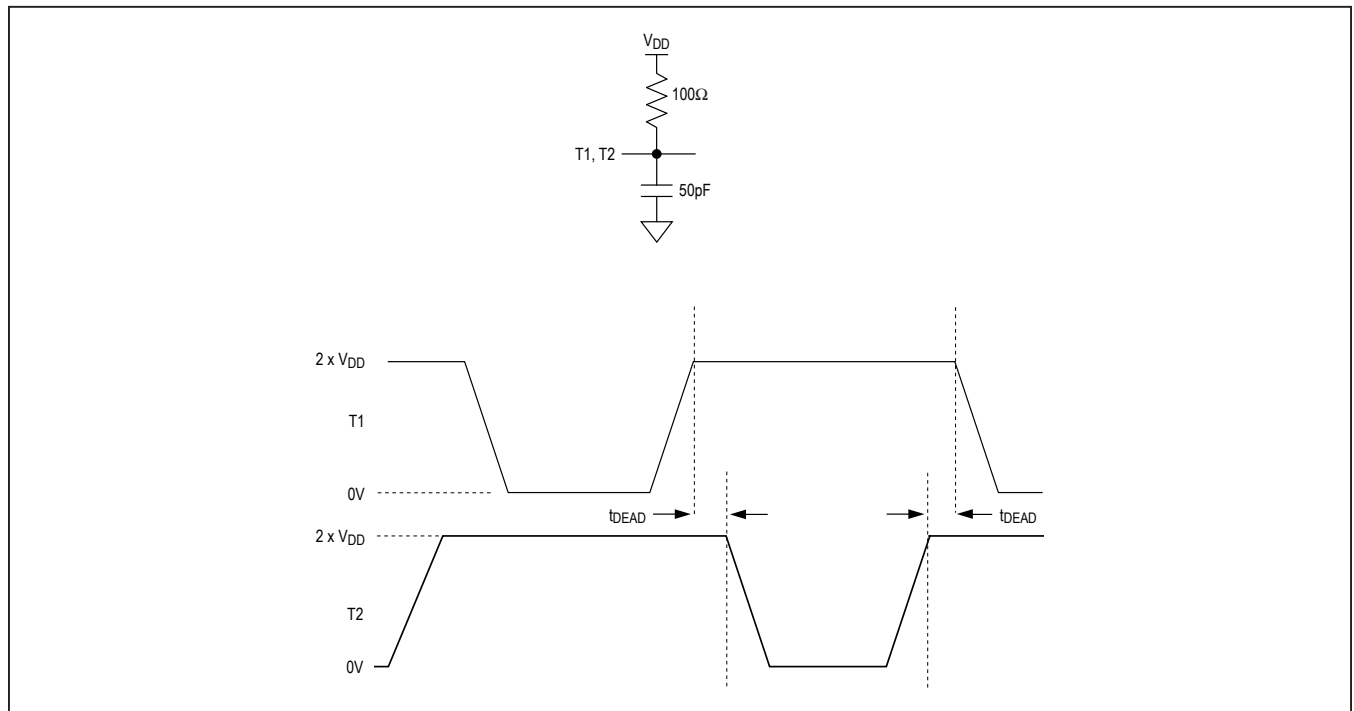
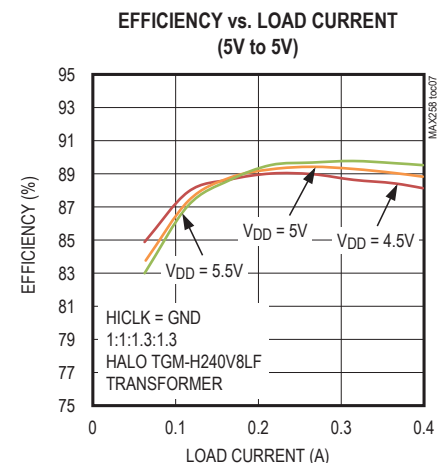
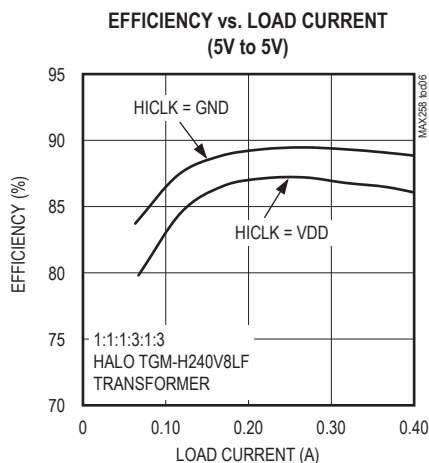
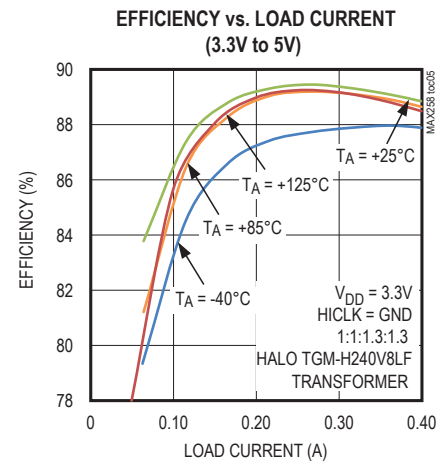
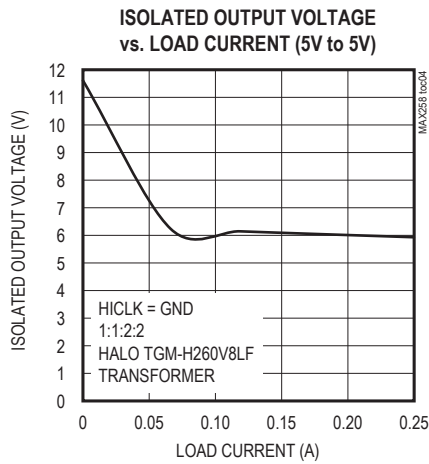
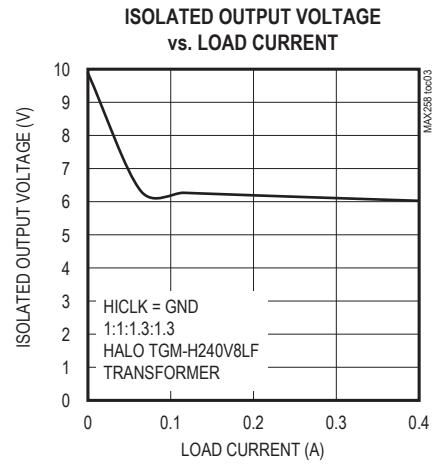
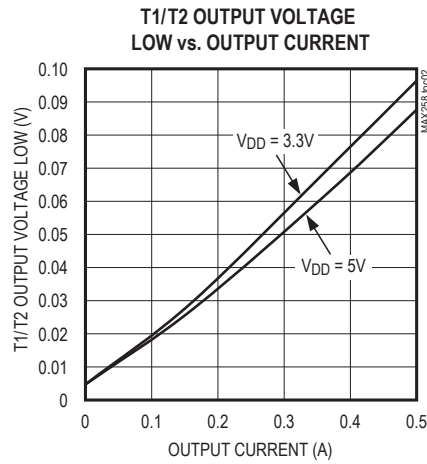
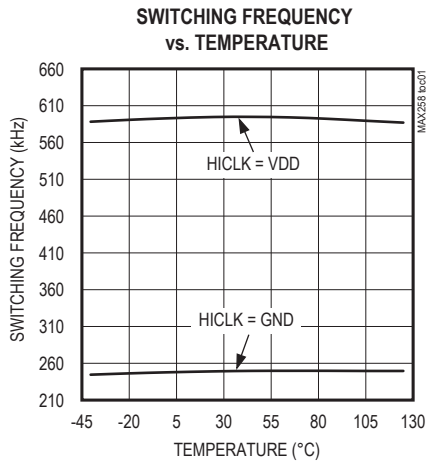

Figure 1. T1, T2 Timing Diagram

Typical Operating Characteristics

($V_{DD} = +5V$, $T_A = +25^\circ C$, unless otherwise noted.)



Typical Operating Characteristics (continued)

($V_{DD} = +5V$, $T_A = +25^\circ C$, unless otherwise noted.)

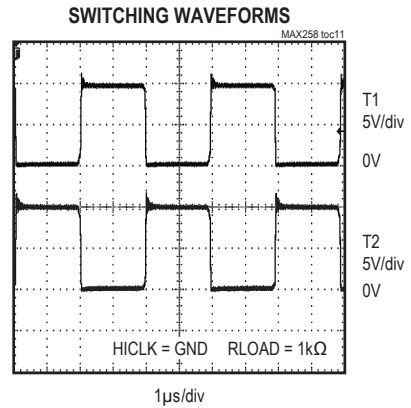
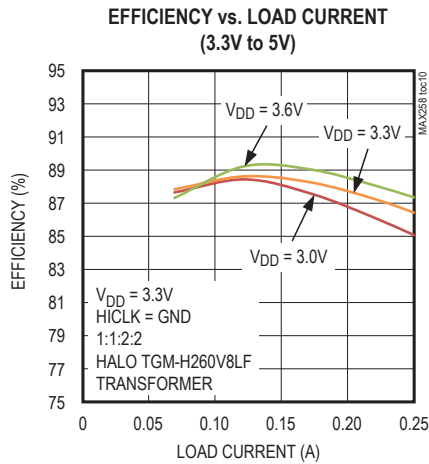
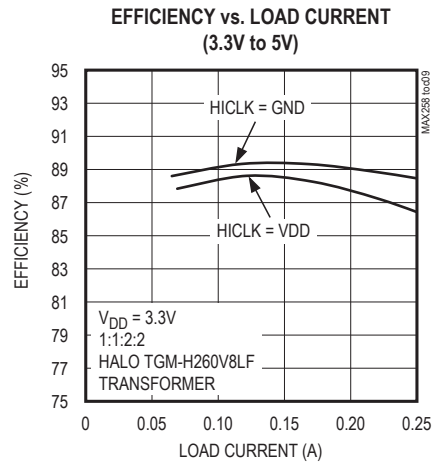
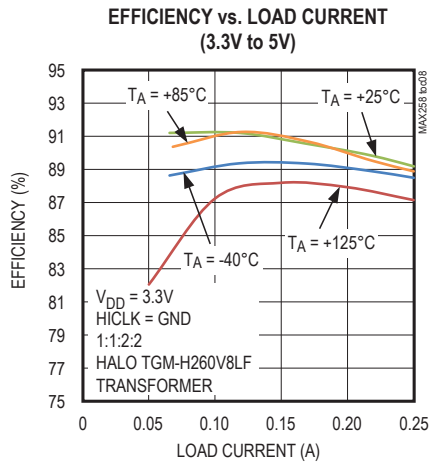

Pin Configuration

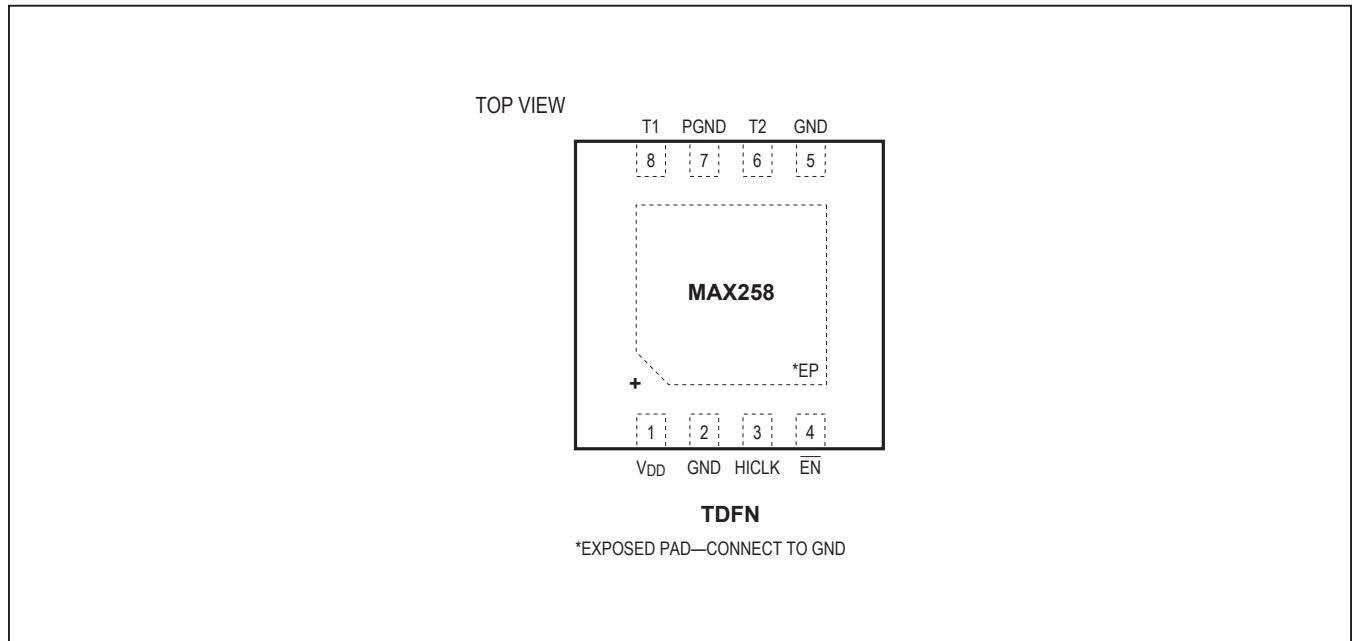

Pin Description

PIN	NAME	FUNCTION
1	V _{DD}	Power-Supply Input. Bypass V _{DD} to GND with a 1μF capacitor as close as possible to the device.
2, 5	GND	Logic and Analog Ground
3	HICLK	Internal Oscillator Frequency Select Input. Drive HICLK high to set the internal oscillator to a 600kHz switching frequency. Drive HICLK low to set the internal oscillator to a 250kHz switching frequency.
4	\overline{EN}	Active-Low Enable Input. Drive \overline{EN} low to enable the device. Drive \overline{EN} high to disable the device.
6	T2	Transformer Drive Output 2
7	PGND	Power Ground. The transformer primary current flows through PGND. Ensure a low-resistance connection to ground.
8	T1	Transformer Drive Output 1
—	EP	Exposed Pad. Internally connected to GND. Connect EP to a large ground plane to maximize thermal performance; not intended as an electrical connection point.

Functional Diagram

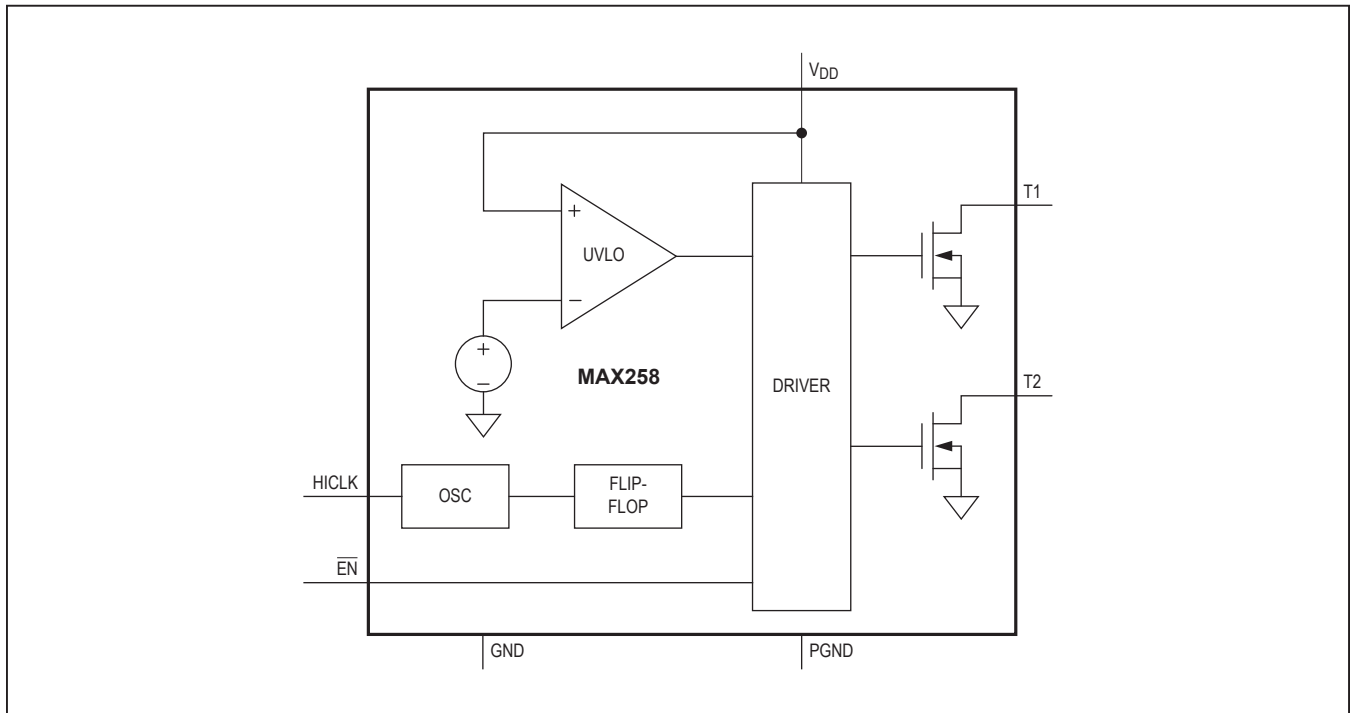

Detailed Description

The MAX258 is an integrated primary-side transformer driver for isolated power-supply circuits. An on-board oscillator and internal MOSFETs provide up to 500mA of drive current to the primary windings of a center-tapped transformer for autonomous operation. The IC features an internal oscillator for autonomous operation. An internal flip-flop stage guarantees a fixed 50% duty cycle to prevent DC current flow in the transformer.

The device operates from a single +3.0V to +5.5V supply and includes undervoltage lockout for controlled startup. Thermal shutdown circuitry provides additional protection against excessive power dissipation.

Isolated Power-Supply Application

The IC allows a versatile range of secondary-side rectification circuits (see [Figure 2](#)). The primary-to-secondary transformer winding ratio can be chosen to adjust the isolated output voltage. The device allows up to 500mA of current into the primary transformer winding with a supply voltage up to +5.5V.

Internal Oscillator

The device includes an internal oscillator with a guaranteed 50% duty cycle. Drive the HICLK input high to set the internal oscillator frequency to 600kHz (typ). Drive the HICLK input low to set the internal oscillator frequency to 250kHz (typ).

Slew-Rate Control

The T1 and T2 drivers feature a controlled slew rate to limit EMI.

Disable Mode

The IC includes a pin-selectable disable mode to reduce current consumption. In disable mode the device consumes less than 5 μ A (max) of supply current. The T1 and T2 outputs are high impedance in disable mode.

Power-Up and Undervoltage Lockout

The IC provides an undervoltage lockout feature to ensure a controlled power-up state and prevent operation before the oscillator has stabilized. On power-up and during normal operation, if the supply voltage drops below V_{UVLO} , the undervoltage-lockout circuit forces the device into disable mode. The T1 and T2 outputs are high impedance in disable mode.

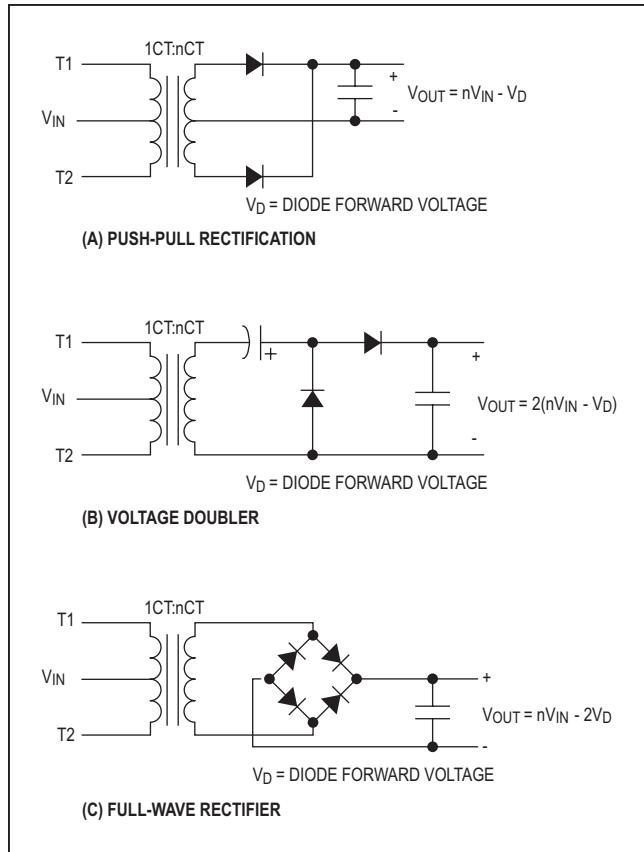

Figure 2. Secondary-Side Rectification Topologies

Thermal Shutdown

The device is protected from overtemperature damage by integrated thermal-shutdown circuitry. When the junction temperature (T_J) exceeds $+160^{\circ}\text{C}$ (typ), the device is disabled. The device resumes normal operation when T_J falls below $+130^{\circ}\text{C}$ (typ).

Applications Information

Power Dissipation

The power dissipation of the device is approximated by:

$$P_D = (R_O \times I_{PRI}^2) + (I_{DD} \times V_{DD})$$

where R_O is the resistance of the internal FET drivers and I_{PRI} is the load current flowing into T1 and T2. Ensure that the power dissipation of the MAX258 is kept below the [Absolute Maximum Ratings](#) for proper operation.

High-Temperature Operation

When the device is operated under high ambient temperatures, the power dissipated in the package can raise the junction temperature close to the thermal shutdown threshold. Under such temperature conditions, the power dissipation should be held low enough that the junction temperature observes a factor of safety margin. The maximum junction temperature should be held below $+140^{\circ}\text{C}$. Use the package’s thermal resistance to calculate the junction temperature.

Power-Supply Decoupling

Bypass V_{DD} to ground with a $1\mu\text{F}$ ceramic capacitor as close as possible to the device.

Connect at least $10\mu\text{F}$ between V_{DD} and ground as close as possible to the primary-side center tap of the transformer. This capacitor helps to stabilize the voltage on the supply line and protects the IC against large voltage spikes on V_{DD} .

Output Voltage Regulation

For many applications, the unregulated output of the circuit meets output voltage tolerances. This configuration represents the highest efficiency possible. When the load currents on the transformer’s secondary side are low, the output voltage of the rectifier can strongly increase. To protect downstream circuitry, limit the output voltage when operating the circuit under low load conditions. If the minimum output load current is less than approximately 5mA , connect a zener diode from the output node of the rectifier to ground to limit the output voltage to a safe value.

For applications requiring a regulated output voltage, Maxim provides several solutions. In the following examples, assume a tolerance of $\pm 10\%$ for the input voltage.

Example 1: 5V to Isolated, Unregulated 6V

In the circuit of [Figure 3](#), the MAX258 is used to generate an isolated 5V output. For a minimum input voltage of 5V, the output voltage of the rectifier is approximately 6V.

Example 2: 3.3V to Isolated, Regulated 5V

In the circuit of [Figure 4](#), the MAX8881 low-dropout linear regulator regulates the isolated output voltage to 5V. A 1:2 center-tapped transformer is used to step-up the secondary-side voltage from a 3.3V input. For a minimum input voltage of 3.3V, the output voltage of the rectifier is approximately 6V.

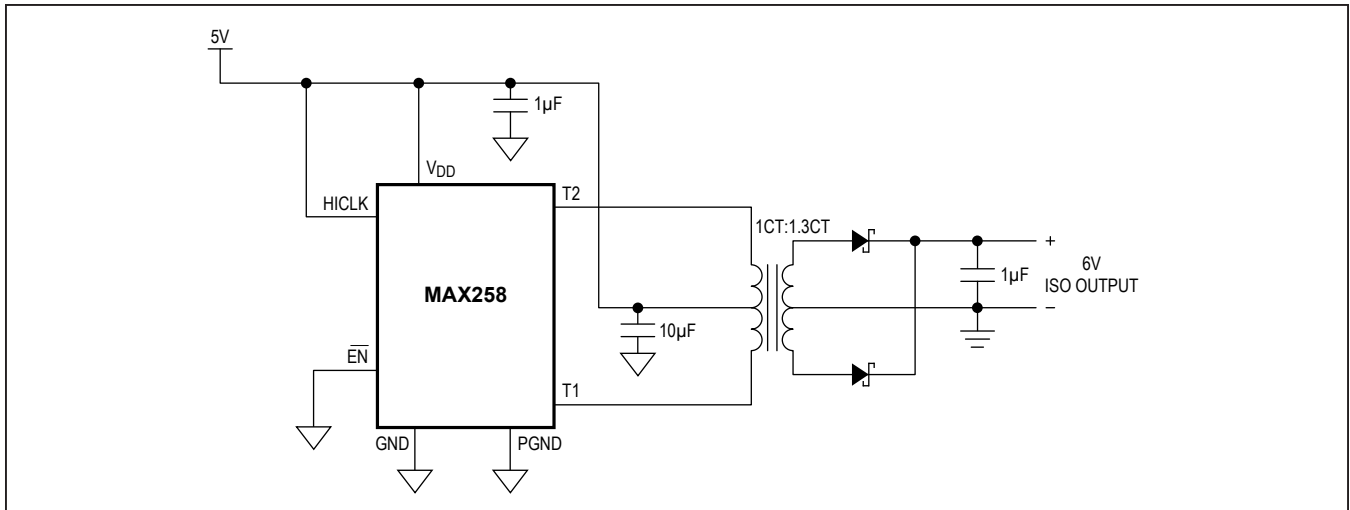

Figure 3. 5V to Isolated, Unregulated 6V Application Circuit

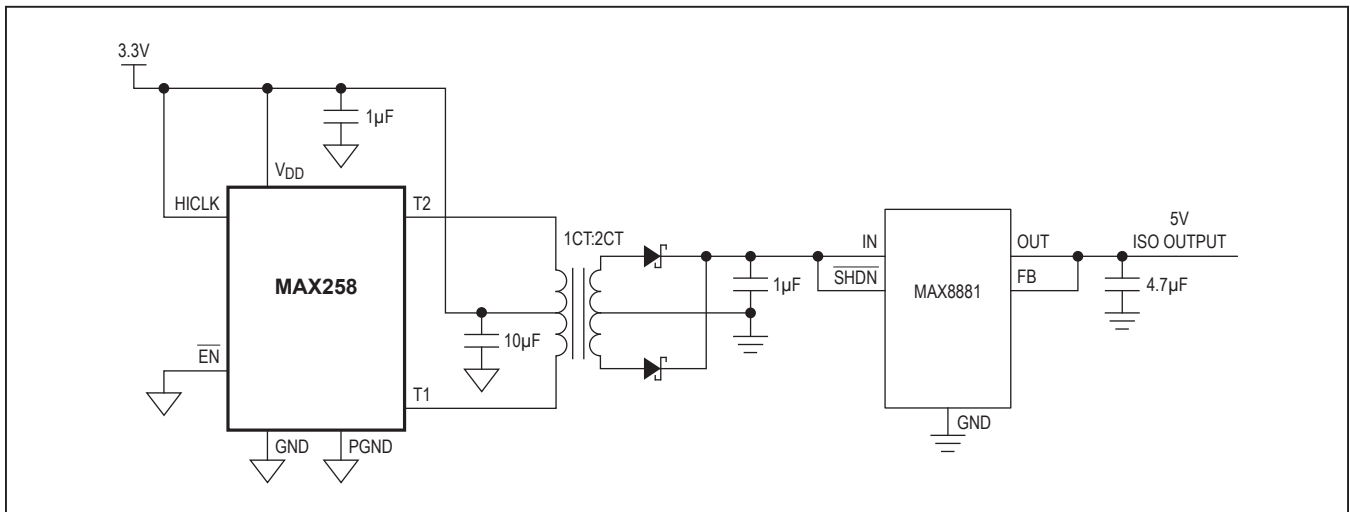

Figure 4. 3.3V to Isolated, Regulated 5V Application Circuit

PCB Layout Guidelines

As with all power-supply circuits, careful PCB layout is important to achieve low switching losses and stable operation. Connect the exposed pad to a solid copper ground plane for optimum thermal performance.

The traces from T1 and T2 to the transformer must be low-resistance and low-inductance paths. Locate the transformer as closely as possible to the MAX258 using short, wide traces.

If possible, use a power plane for all V_{DD} connections to the MAX258 and the primary-side of the transformer. If a power plane is not available, avoid damage to the IC by

ensuring that the current flowing through the primary-side center tap of the transformer does not flow through the same trace that connects the supply pin of the MAX258 to the V_{DD} source, and connect the primary-side center tap to the V_{DD} supply using a very low inductance connection.

Exposed Pad

For optimal thermal performance, ensure that the exposed pad has a low thermal resistance connection to the ground plane. Failure to provide a low thermal impedance path to the ground plane results in excessive junction temperatures when dissipating high power.

Component Selection

Transformer Selection

Transformer selection for the MAX258 can be simplified by the use of the ET product. The ET product relates the maximum allowable magnetic flux density in a transformer core to the voltage across a winding and switching period. Inductor magnetizing current in the primary winding changes linearly with time during the switching period of the device. Each transformer has a minimum ET product, though not always stated on the transformer data sheet. Ensure that the transformer selected for use with the device has an ET product of at least $ET = V_{DD}/(2 \times f_{SW})$ for each half of the primary winding, where f_{SW} is the minimum switching frequency of the T1 and T2 outputs.

Select a transformer with sufficient ET product for each half of the primary winding to ensure that the transformer does not saturate during operation. Saturation of the magnetic core results in significantly reduced inductance of the primary, and therefore in a large increase in current flow.

For example, when HICLK is low, the required transformer ET product to the center tap for an application with $V_{DD}(\text{max}) = 5.5\text{V}$, is $13.1\text{V}\cdot\mu\text{s}$. An application with $V_{DD}(\text{max}) = 3.3\text{V}$ has a transformer ET product to the center tap requirement of $7.9\text{V}\cdot\mu\text{s}$.

In addition to the constraint on ET product, choose a transformer with low leakage inductance and low DC-winding resistance. Power dissipation of the transformer due to the copper loss is approximated as:

$$P_{D_TX} = I_{LOAD}^2 \times (R_{PRI}/N^2 + R_{SEC})$$

where R_{PRI} is the DC-winding resistance of the primary, and R_{SEC} is the DC-winding resistance of the secondary. In most cases, an optimum is reached when $R_{SEC} = R_{PRI}/N^2$. For this condition, the power dissipation is equal for the primary and secondary windings.

As with all power-supply designs, it is important to optimize efficiency. In designs incorporating small transformers, the possibility of thermal runaway makes low transformer efficiencies problematic. Transformer losses produce

a temperature rise that reduces the efficiency of the transformer. The lower efficiency, in turn, produces an even larger temperature rise.

To ensure that the transformer meets these requirements under all operating conditions, the design should focus on the worst-case conditions. The most stringent demands on ET product arise for maximum input voltage, minimum switching frequency, and maximum temperature and load current. Additionally, the worst-case values for transformer and rectifier losses should be considered.

The primary must be center-tapped; however the secondary winding may or may not be center-tapped, depending on the rectifier topology used. The phasing between primary and secondary windings is not critical.

The transformer turns ratio must be set to provide the minimum required output voltage at the maximum anticipated load with the minimum expected input voltage. In addition, include in the calculations an allowance for the worst-case losses in the rectifiers. Since the turns ratio determined in this manner ordinarily produces a much higher voltage at the secondary under conditions of high input voltage and/or light loading, take care to prevent an overvoltage condition from occurring.

Transformers for use with the IC are typically wound on a high-permeability magnetic core. To minimize radiated electromagnetic emissions, select a toroid, pot core, E/I/U core, or equivalent.

Diode Selection

The high switching speed capability of the MAX258 necessitates high-speed rectifiers. Ordinary silicon signal diodes such as the 1N914 or 1N4148 can be used for low-output current levels (less than 50mA), but at high-output current levels, their reverse recovery times might degrade efficiency. At higher output currents, select low forward-voltage Schottky diodes to improve efficiency. Ensure that the average forward current rating for the rectifier diodes exceeds the maximum load current of the circuit. For surface-mount applications, Schottky diodes such as the B230A, MBRS230, and MBRS320 are recommended.

Table 1. Suggested External Component Manufacturers

MANUFACTURER	COMPONENT	WEBSITE
Halo Electronics	Transformers	www.haloelectronics.com
Würth Electronics	Transformers	www.we-online.com
Diodes Inc.	Diodes	www.diodes.com
Murata Americas	Capacitors	www.murataamericas.com

MAX258

500mA, Push-Pull Transformer Driver
for Isolated Power Supplies

Ordering Information

PART	TEMP RANGE	PIN-PACKAGE
MAX258ATA+	-40°C to +125°C	8 TDFN-EP*

+Denotes a lead(Pb)-free/RoHS-compliant package.

*EP = Exposed pad.

Chip Information

PROCESS: BiCMOS

Revision History

REVISION NUMBER	REVISION DATE	DESCRIPTION	PAGES CHANGED
0	5/13	Initial release	—
1	9/18	Updated TOC04–TOC10, and Table 1	4–5, 10

For pricing, delivery, and ordering information, please visit Maxim Integrated's online storefront at <https://www.maximintegrated.com/en/storefront/storefront.html>.

Maxim Integrated cannot assume responsibility for use of any circuitry other than circuitry entirely embodied in a Maxim Integrated product. No circuit patent licenses are implied. Maxim Integrated reserves the right to change the circuitry and specifications without notice at any time. The parametric values (min and max limits) shown in the Electrical Characteristics table are guaranteed. Other parametric values quoted in this data sheet are provided for guidance.