

# Dual, Ultra-Low-Power, 10-Bit, Voltage-Output DACs

## ABSOLUTE MAXIMUM RATINGS

|   |                                   |
|---|-----------------------------------|
| V <sub>DD</sub> to GND                                | -0.3V to +6V                      |
| OUTA, OUTB to GND                                     | -0.3V to (V <sub>DD</sub> + 0.3V) |
| FBA, FBB to GND                                       | -0.3V to (V <sub>DD</sub> + 0.3V) |
| SCLK, DIN, CS to GND                                  | -0.3V to (V <sub>DD</sub> + 0.3V) |
| REFIN, REFOUT to GND                                  | -0.3V to (V <sub>DD</sub> + 0.3V) |
| Continuous Power Dissipation (T <sub>A</sub> = +70°C) |                                   |
| 12-Pin Thin QFN (derate 16.9mW/°C above +70°C)        | 1349mW                            |
| 8-Pin µMAX (derate 5.9mW/°C above +70°C)              | 471mW                             |

|                                   |                 |
|-----------------------------------|-----------------|
| Operating Temperature Range       | -40°C to +85°C  |
| Storage Temperature Range         | -65°C to +150°C |
| Junction Temperature              | +150°C          |
| Lead Temperature (soldering, 10s) | +300°C          |

Stresses beyond those listed under "Absolute Maximum Ratings" may cause permanent damage to the device. These are stress ratings only, and functional operation of the device at these or any other conditions beyond those indicated in the operational sections of the specifications is not implied. Exposure to absolute maximum rating conditions for extended periods may affect device reliability.

## ELECTRICAL CHARACTERISTICS

(V<sub>DD</sub> = +1.8V to +5.5V, OUT\_ unloaded, T<sub>A</sub> = T<sub>MIN</sub> to T<sub>MAX</sub>, unless otherwise noted. Typical values are at T<sub>A</sub> = +25°C.)

| PARAMETER   | SYMBOL          | CONDITIONS  | MIN | TYP  | MAX | UNITS  |
|---|-----------------|---|-----|------|-----|--------|
| <b>STATIC ACCURACY (MAX5522/MAX5524 EXTERNAL REFERENCE)</b> |                 |   |     |      |     |        |
| Resolution  | N               |   | 10  |      |     | Bits   |
| Integral Nonlinearity (Note 1)                              | INL             | V <sub>DD</sub> = 5V, V <sub>REF</sub> = 4.096V                         |     | ±1   | ±4  | LSB    |
|   |                 | V <sub>DD</sub> = 1.8V, V <sub>REF</sub> = 1.024V                       |     | ±1   | ±4  |        |
| Differential Nonlinearity (Note 1)                          | DNL             | Guaranteed monotonic, V <sub>DD</sub> = 5V, V <sub>REF</sub> = 4.096V   |     | ±0.2 | ±1  | LSB    |
|   |                 | Guaranteed monotonic, V <sub>DD</sub> = 1.8V, V <sub>REF</sub> = 1.024V |     | ±0.2 | ±1  |        |
| Offset Error (Note 2)                                       | V <sub>OS</sub> | V <sub>DD</sub> = 5V, V <sub>REF</sub> = 4.096V                         |     | ±1   | ±20 | mV     |
|   |                 | V <sub>DD</sub> = 1.8V, V <sub>REF</sub> = 1.024V                       |     | ±1   | ±20 |        |
| Offset-Error Temperature Drift                              |                 |   |     | ±2   |     | µV/°C  |
| Gain Error (Note 3)   | GE              | V <sub>DD</sub> = 5V, V <sub>REF</sub> = 4.096V                         |     | ±0.5 | ±2  | LSB    |
|   |                 | V <sub>DD</sub> = 1.8V, V <sub>REF</sub> = 1.024V                       |     | ±0.5 | ±2  |        |
| Gain-Error Temperature Coefficient                          |                 |   |     | ±4   |     | ppm/°C |
| Power-Supply Rejection Ratio                                | PSRR            | 1.8V ≤ V <sub>DD</sub> ≤ 5.5V   |     | 85   |     | dB     |
| <b>STATIC ACCURACY (MAX5523/MAX5525 INTERNAL REFERENCE)</b> |                 |   |     |      |     |        |
| Resolution  | N               |   | 10  |      |     | Bits   |
| Integral Nonlinearity (Note 1)                              | INL             | V <sub>DD</sub> = 5V, V <sub>REF</sub> = 3.9V                           |     | ±1   | ±4  | LSB    |
|   |                 | V <sub>DD</sub> = 1.8V, V <sub>REF</sub> = 1.2V                         |     | ±1   | ±4  |        |
| Differential Nonlinearity (Note 1)                          | DNL             | Guaranteed monotonic, V <sub>DD</sub> = 5V, V <sub>REF</sub> = 3.9V     |     | ±0.2 | ±1  | LSB    |
|   |                 | Guaranteed monotonic, V <sub>DD</sub> = 1.8V, V <sub>REF</sub> = 1.2V   |     | ±0.2 | ±1  |        |
| Offset Error (Note 2)                                       | V <sub>OS</sub> | V <sub>DD</sub> = 5V, V <sub>REF</sub> = 3.9V                           |     | ±1   | ±20 | mV     |
|   |                 | V <sub>DD</sub> = 1.8V, V <sub>REF</sub> = 1.2V                         |     | ±1   | ±20 |        |
| Offset-Error Temperature Drift                              |                 |   |     | ±2   |     | µV/°C  |
| Gain Error (Note 3)   | GE              | V <sub>DD</sub> = 5V, V <sub>REF</sub> = 3.9V                           |     | ±0.5 | ±2  | LSB    |
|   |                 | V <sub>DD</sub> = 1.8V, V <sub>REF</sub> = 1.2V                         |     | ±0.5 | ±2  |        |
| Gain-Error Temperature Coefficient                          |                 |   |     | ±4   |     | ppm/°C |

# Dual, Ultra-Low-Power, 10-Bit, Voltage-Output DACs

MAX5522-MAX5525

## ELECTRICAL CHARACTERISTICS (continued)

( $V_{DD} = +1.8V$  to  $+5.5V$ ,  $OUT_+$  unloaded,  $T_A = T_{MIN}$  to  $T_{MAX}$ , unless otherwise noted. Typical values are at  $T_A = +25^\circ C$ .)

| PARAMETER                                 | SYMBOL       | CONDITIONS   | MIN   | TYP     | MAX      | UNITS           |
|---|--------------|--|-------|---------|----------|-----------------|
| Power-Supply Rejection Ratio              | PSRR         | $1.8V \leq V_{DD} \leq 5.5V$   |       | 85      |          | dB              |
| <b>REFERENCE INPUT (MAX5522/MAX5524)</b>  |              |  |       |         |          |                 |
| Reference-Input Voltage Range             | $V_{REFIN}$  |  | 0     |         | $V_{DD}$ | V               |
| Reference-Input Impedance                 | $R_{REFIN}$  | Normal operation   | 4.1   |         |          | $M\Omega$       |
|   |              | In shutdown  |       | 2.5     |          | $G\Omega$       |
| <b>REFERENCE OUTPUT (MAX5523/MAX5525)</b> |              |  |       |         |          |                 |
| Initial Accuracy                          | $V_{REFOUT}$ | No external load, $V_{DD} = 1.8V$  | 1.197 | 1.214   | 1.231    | V               |
|   |              | No external load, $V_{DD} = 2.5V$  | 1.913 | 1.940   | 1.967    |                 |
|   |              | No external load, $V_{DD} = 3V$  | 2.391 | 2.425   | 2.459    |                 |
|   |              | No external load, $V_{DD} = 5V$  | 3.828 | 3.885   | 3.941    |                 |
| Output-Voltage Temperature Coefficient    | $V_{TEMPCO}$ | $T_A = -40^\circ C$ to $+85^\circ C$ (Note 4)                                      |       | 12      | 30       | ppm/ $^\circ C$ |
| Line Regulation                           |              | $V_{REFOUT} < V_{DD} - 200mV$ (Note 5)   |       | 2       | 200      | $\mu V/V$       |
| Load Regulation                           |              | $0 \leq I_{REFOUT} \leq 1mA$ , sourcing, $V_{DD} = 1.8V$ , $V_{REF} = 1.2V$        |       | 0.3     | 2        | $\mu V/\mu A$   |
|   |              | $0 \leq I_{REFOUT} \leq 8mA$ , sourcing, $V_{DD} = 5V$ , $V_{REF} = 3.9V$          |       | 0.3     | 2        |                 |
|   |              | $-150\mu A \leq I_{REFOUT} \leq 0$ , sinking                                       |       | 0.2     |          |                 |
| Output Noise Voltage                      |              | 0.1Hz to 10Hz, $V_{REF} = 3.9V$  |       | 150     |          | $\mu V_{P-P}$   |
|   |              | 10Hz to 10kHz, $V_{REF} = 3.9V$  |       | 600     |          |                 |
|   |              | 0.1Hz to 10Hz, $V_{REF} = 1.2V$  |       | 50      |          |                 |
|   |              | 10Hz to 10kHz, $V_{REF} = 1.2V$  |       | 450     |          |                 |
| Short-Circuit Current (Note 6)            |              | $V_{DD} = 5V$  |       | 30      |          | mA              |
|   |              | $V_{DD} = 1.8V$  |       | 14      |          |                 |
| Capacitive Load Stability Range           |              | (Note 7)   |       | 0 to 10 |          | nF              |
| Thermal Hysteresis                        |              | (Note 8)   |       | 200     |          | ppm             |
| Reference Power-Up Time (from Shutdown)   |              | REFOUT unloaded, $V_{DD} = 5V$   |       | 5.4     |          | ms              |
|   |              | REFOUT unloaded, $V_{DD} = 1.8V$   |       | 4.4     |          |                 |
| Long-Term Stability                       |              |  |       | 200     |          | ppm/<br>1khrs   |
| <b>DAC OUTPUTS (OUTA, OUTB)</b>           |              |  |       |         |          |                 |
| Capacitive Driving Capability             | $C_L$        |  |       | 1000    |          | pF              |
| Short-Circuit Current (Note 6)            |              | $V_{DD} = 5V$ , $V_{OUT}$ set to full scale, $OUT$ shorted to GND, source current  |       |         | 65       | mA              |
|   |              | $V_{DD} = 5V$ , $V_{OUT}$ set to 0V, $OUT$ shorted to $V_{DD}$ , sink current      |       |         | 65       |                 |
|   |              | $V_{DD} = 1.8V$ , $V_{OUT}$ set to full scale $OUT$ shorted to GND, source current |       |         | 14       |                 |
|   |              | $V_{DD} = 1.8V$ , $V_{OUT}$ set to 0V, $OUT$ shorted to $V_{DD}$ , sink current    |       |         | 14       |                 |

# Dual, Ultra-Low-Power, 10-Bit, Voltage-Output DACs

## ELECTRICAL CHARACTERISTICS (continued)

( $V_{DD} = +1.8V$  to  $+5.5V$ ,  $OUT_+$  unloaded,  $T_A = T_{MIN}$  to  $T_{MAX}$ , unless otherwise noted. Typical values are at  $T_A = +25^\circ C$ .)

| PARAMETER   | SYMBOL     | CONDITIONS  |                              | MIN                 | TYP       | MAX           | UNITS |
|---|------------|---|------------------------------|---------------------|-----------|---------------|-------|
| DAC Power-Up Time   |            | Coming out of shutdown<br>(MAX5522/MAX5524)             | $V_{DD} = 5V$                | 3                   |           | $\mu s$       |       |
|   |            |   | $V_{DD} = 1.8V$              | 3.8                 |           |               |       |
|   |            | Coming out of standby<br>(MAX5523/MAX5525)              | $V_{DD} = 1.8V$ to<br>$5.5V$ | 0.4                 |           |               |       |
| Output Power-Up Glitch  |            | $C_L = 100pF$   |                              | 10                  |           | mV            |       |
| FB_ Input Current   |            |   |                              | 10                  |           | pA            |       |
| <b>DIGITAL INPUTS (SCLK, DIN, <math>\overline{CS}</math>)</b> |            |   |                              |                     |           |               |       |
| Input High Voltage  | $V_{IH}$   | $4.5V \leq V_{DD} \leq 5.5V$                            |                              | 2.4                 |           | V             |       |
|   |            | $2.7V < V_{DD} \leq 3.6V$                               |                              | 2.0                 |           |               |       |
|   |            | $1.8V \leq V_{DD} \leq 2.7V$                            |                              | $0.7 \times V_{DD}$ |           |               |       |
| Input Low Voltage   | $V_{IL}$   | $4.5V \leq V_{DD} \leq 5.5V$                            |                              | 0.8                 |           | V             |       |
|   |            | $2.7V < V_{DD} \leq 3.6V$                               |                              | 0.6                 |           |               |       |
|   |            | $1.8V \leq V_{DD} \leq 2.7V$                            |                              | $0.3 \times V_{DD}$ |           |               |       |
| Input Leakage Current   | $I_{IN}$   | (Note 9)  |                              | $\pm 0.05$          | $\pm 0.5$ | $\mu A$       |       |
| Input Capacitance   | $C_{IN}$   |   |                              | 10                  |           | pF            |       |
| <b>DYNAMIC PERFORMANCE</b>                                    |            |   |                              |                     |           |               |       |
| Voltage-Output Slew Rate                                      | SR         | Positive and negative (Note 10)                         |                              | 10                  |           | V/ms          |       |
| Voltage-Output Settling Time                                  |            | 0.1 to 0.9 of full scale to within 0.5 LSB<br>(Note 10) |                              | 660                 |           | $\mu s$       |       |
| Output Noise Voltage  |            | 0.1Hz to 10Hz   | $V_{DD} = 5V$                | 80                  |           | $\mu V_{P-P}$ |       |
|   |            |   | $V_{DD} = 1.8V$              | 55                  |           |               |       |
|   |            | 10Hz to 10kHz   | $V_{DD} = 5V$                | 620                 |           |               |       |
|   |            |   | $V_{DD} = 1.8V$              | 476                 |           |               |       |
| <b>POWER REQUIREMENTS</b>                                     |            |   |                              |                     |           |               |       |
| Supply Voltage Range  | $V_{DD}$   |   |                              | 1.8                 |           | 5.5           | V     |
| Supply Current (Note 9)                                       | $I_{DD}$   | MAX5523/MAX5525   | $V_{DD} = 5V$                | 7.0                 | 8.0       | $\mu A$       |       |
|   |            |   | $V_{DD} = 3V$                | 6.4                 | 8.0       |               |       |
|   |            |   | $V_{DD} = 1.8V$              | 7.0                 | 8.0       |               |       |
|   |            | MAX5522/MAX5524   | $V_{DD} = 5V$                | 3.8                 | 5.0       |               |       |
|   |            |   | $V_{DD} = 3V$                | 3.8                 | 5.0       |               |       |
|   |            |   | $V_{DD} = 1.8V$              | 4.7                 | 6.0       |               |       |
| Standby Supply Current  | $I_{DDSD}$ | MAX5523/MAX5525<br>(Note 9)                             | $V_{DD} = 5V$                | 3.3                 | 4.5       | $\mu A$       |       |
|   |            |   | $V_{DD} = 3V$                | 2.8                 | 4.0       |               |       |
|   |            |   | $V_{DD} = 1.8V$              | 2.4                 | 3.5       |               |       |
| Shutdown Supply Current                                       | $I_{DDPD}$ | (Note 9)  |                              | 0.05                | 0.25      | $\mu A$       |       |

# Dual, Ultra-Low-Power, 10-Bit, Voltage-Output DACs

MAX5522-MAX5525

## TIMING CHARACTERISTICS

( $V_{DD} = +4.5V$  to  $+5.5V$ ,  $T_A = T_{MIN}$  to  $T_{MAX}$ , unless otherwise noted. Typical values are at  $T_A = +25^\circ C$ .)

| PARAMETER   | SYMBOL            | CONDITIONS | MIN | TYP | MAX  | UNITS |
|---|-------------------|------------|-----|-----|------|-------|
| <b>TIMING CHARACTERISTICS (<math>V_{DD} = 4.5V</math> to <math>5.5V</math>)</b> |                   |            |     |     |      |       |
| Serial Clock Frequency  | f <sub>SCLK</sub> |            | 0   |     | 16.7 | MHz   |
| DIN to SCLK Rise Setup Time   | t <sub>DS</sub>   |            | 15  |     |      | ns    |
| DIN to SCLK Rise Hold Time  | t <sub>DH</sub>   |            | 0   |     |      | ns    |
| SCLK Pulse-Width High   | t <sub>CH</sub>   |            | 24  |     |      | ns    |
| SCLK Pulse-Width Low  | t <sub>CL</sub>   |            | 24  |     |      | ns    |
| $\overline{CS}$ Pulse-Width High  | t <sub>CSW</sub>  |            | 100 |     |      | ns    |
| SCLK Rise to $\overline{CS}$ Rise Hold Time                                     | t <sub>CSH</sub>  |            | 0   |     |      | ns    |
| $\overline{CS}$ Fall to SCLK Rise Setup Time                                    | t <sub>CSS</sub>  |            | 20  |     |      | ns    |
| SCLK Fall to $\overline{CS}$ Fall Setup   | t <sub>CSO</sub>  |            | 0   |     |      | ns    |
| $\overline{CS}$ Rise to SCK Rise Hold Time                                      | t <sub>CS1</sub>  |            | 20  |     |      | ns    |

## TIMING CHARACTERISTICS

( $V_{DD} = +1.8V$  to  $+5.5V$ ,  $T_A = T_{MIN}$  to  $T_{MAX}$ , unless otherwise noted. Typical values are at  $T_A = +25^\circ C$ .)

| PARAMETER   | SYMBOL            | CONDITIONS | MIN | TYP | MAX | UNITS |
|---|-------------------|------------|-----|-----|-----|-------|
| <b>TIMING CHARACTERISTICS (<math>V_{DD} = 1.8V</math> to <math>5.5V</math>)</b> |                   |            |     |     |     |       |
| Serial Clock Frequency  | f <sub>SCLK</sub> |            | 0   |     | 10  | MHz   |
| DIN to SCLK Rise Setup Time   | t <sub>DS</sub>   |            | 24  |     |     | ns    |
| DIN to SCLK Rise Hold Time  | t <sub>DH</sub>   |            | 0   |     |     | ns    |
| SCLK Pulse-Width High   | t <sub>CH</sub>   |            | 40  |     |     | ns    |
| SCLK Pulse-Width Low  | t <sub>CL</sub>   |            | 40  |     |     | ns    |
| $\overline{CS}$ Pulse-Width High  | t <sub>CSW</sub>  |            | 150 |     |     | ns    |
| SCLK Rise to $\overline{CS}$ Rise Hold Time                                     | t <sub>CSH</sub>  |            | 0   |     |     | ns    |
| $\overline{CS}$ Fall to SCLK Rise Setup Time                                    | t <sub>CSS</sub>  |            | 30  |     |     | ns    |
| SCLK Fall to $\overline{CS}$ Fall Setup   | t <sub>CSO</sub>  |            | 0   |     |     | ns    |
| $\overline{CS}$ Rise to SCK Rise Hold Time                                      | t <sub>CS1</sub>  |            | 30  |     |     | ns    |

**Note 1:** Linearity is tested within codes 24 to 1020.

**Note 2:** Offset is tested at code 24.

**Note 3:** Gain is tested at code 1023. For the MAX5524/MAX5525, FB<sub>-</sub> is connected to its respective OUT<sub>-</sub>.

**Note 4:** Guaranteed by design. Not production tested

**Note 5:**  $V_{DD}$  must be a minimum of 1.8V.

**Note 6:** Outputs can be shorted to  $V_{DD}$  or GND indefinitely, provided that package power dissipation is not exceeded.

**Note 7:** Optimal noise performance is at 2nF load capacitance.

**Note 8:** Thermal hysteresis is defined as the change in the initial  $+25^\circ C$  output voltage after cycling the device from  $T_{MAX}$  to  $T_{MIN}$ .

**Note 9:** All digital inputs at  $V_{DD}$  or GND.

**Note 10:** Load = 10k $\Omega$  in parallel with 100pF,  $V_{DD} = 5V$ ,  $V_{REF} = 4.096V$  (MAX5522/MAX5524) or  $V_{REF} = 3.9V$  (MAX5523/MAX5525).

# Dual, Ultra-Low-Power, 10-Bit, Voltage-Output DACs

## Typical Operating Characteristics

( $V_{DD} = 5.0V$ ,  $V_{REF} = 4.096V$  (MAX5522/MAX5524),  $V_{REF} = 3.9V$  (MAX5523/MAX5525),  $T_A = +25^\circ C$ , unless otherwise noted.)

**SUPPLY CURRENT vs. SUPPLY VOLTAGE (MAX5522/MAX5524)**

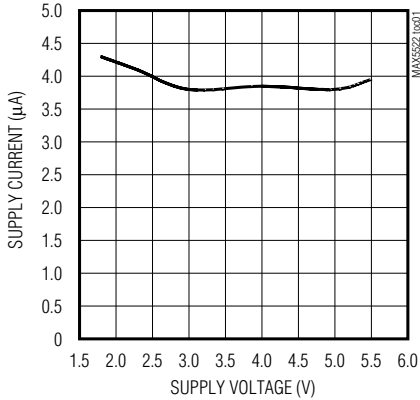

**SUPPLY CURRENT vs. TEMPERATURE (MAX5522/MAX5524)**

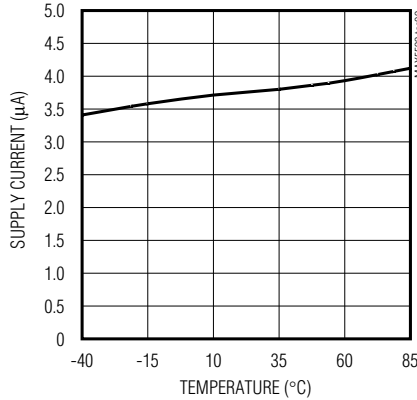

**SUPPLY CURRENT vs. SUPPLY VOLTAGE (MAX5523/MAX5525)**

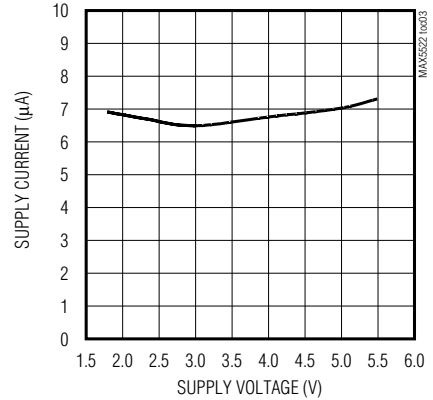

**SUPPLY CURRENT vs. TEMPERATURE (MAX5523/MAX5525)**

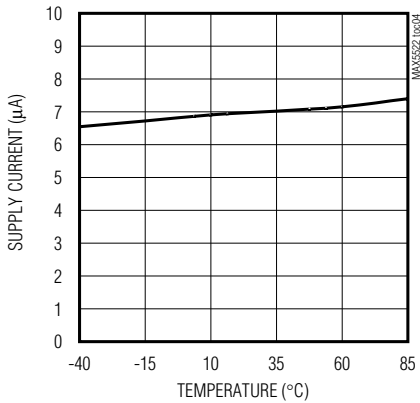

**SHUTDOWN SUPPLY CURRENT vs. TEMPERATURE (MAX5522/MAX5524)**

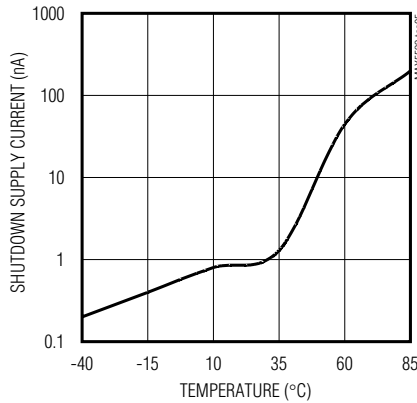

**SHUTDOWN SUPPLY CURRENT vs. TEMPERATURE (MAX5523/MAX5525)**

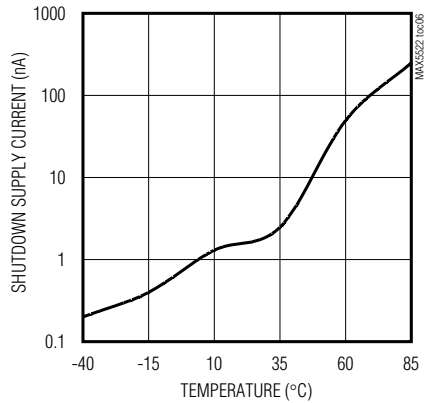

**STANDBY SUPPLY CURRENT vs. TEMPERATURE (MAX5523/MAX5525)**

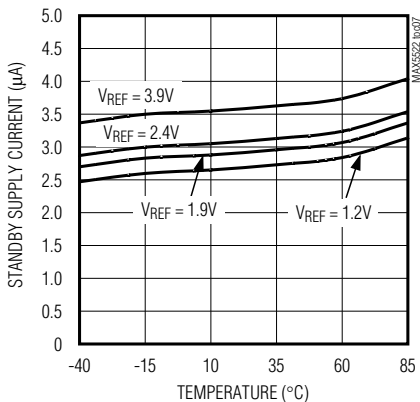

**SUPPLY CURRENT vs. CLOCK FREQUENCY**

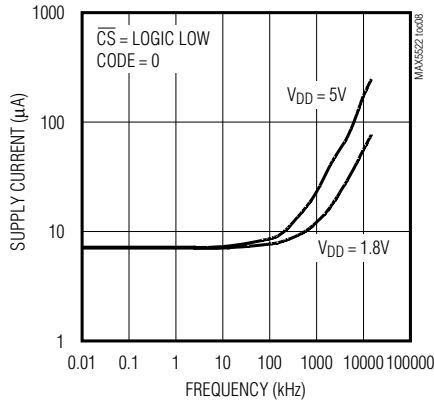

**SUPPLY CURRENT vs. LOGIC INPUT VOLTAGE**

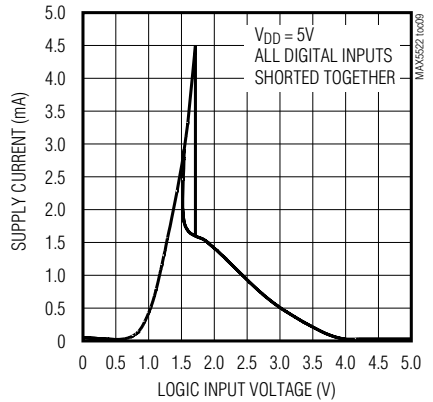

# Dual, Ultra-Low-Power, 10-Bit, Voltage-Output DACs

## Typical Operating Characteristics (continued)

( $V_{DD} = 5.0V$ ,  $V_{REF} = 4.096V$  (MAX5522/MAX5524),  $V_{REF} = 3.9V$  (MAX5523/MAX54525),  $T_A = +25^\circ C$ , unless otherwise noted.)

MAX5522-MAX5525

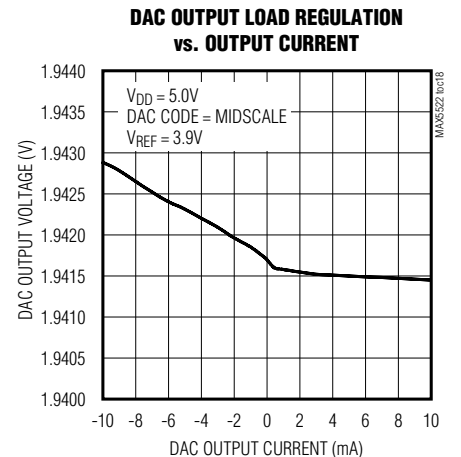
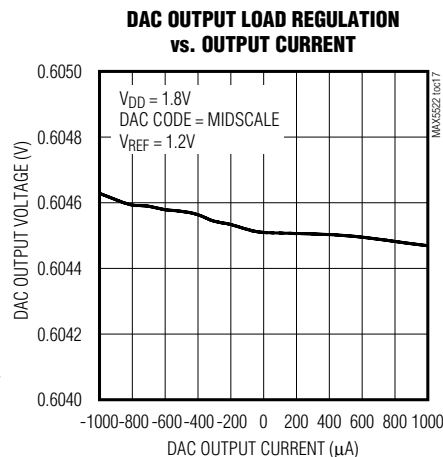
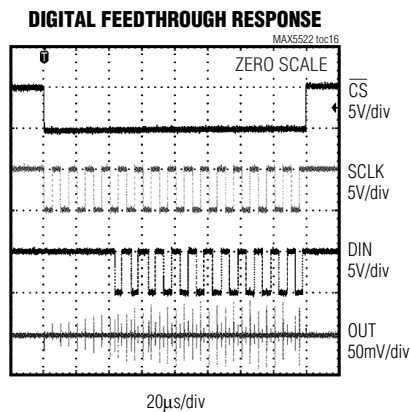
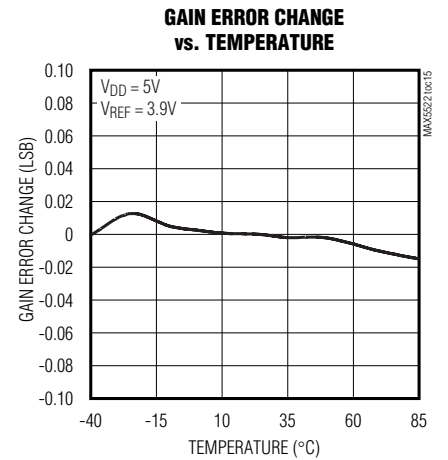
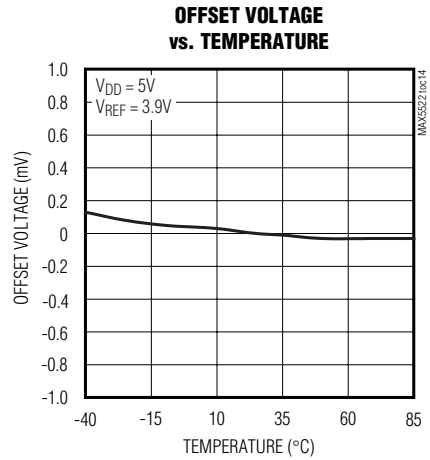
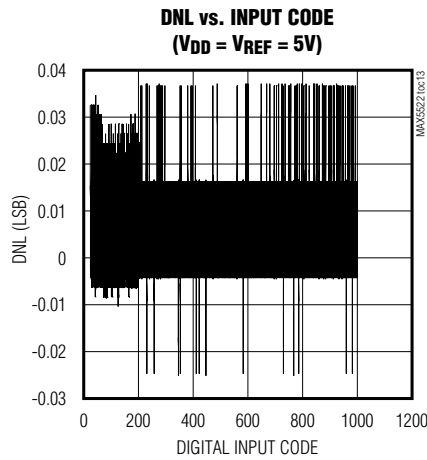
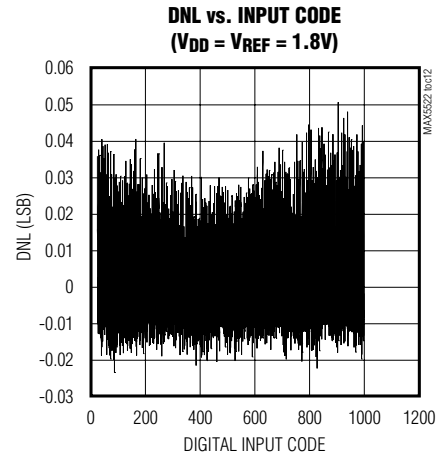
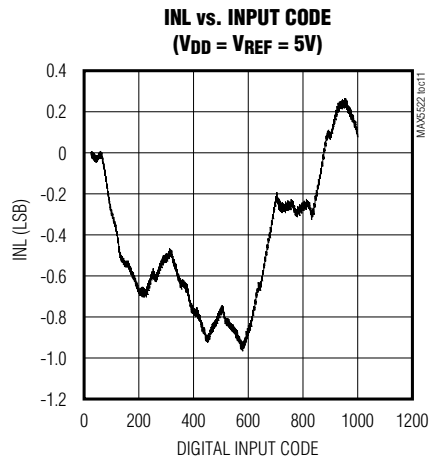
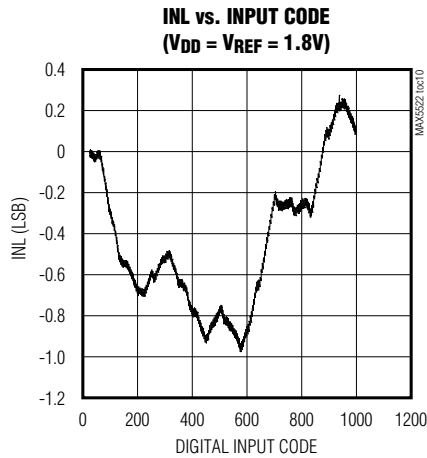

# Dual, Ultra-Low-Power, 10-Bit, Voltage-Output DACs

## Typical Operating Characteristics (continued)

( $V_{DD} = 5.0V$ ,  $V_{REF} = 4.096V$  (MAX5522/MAX5524),  $V_{REF} = 3.9V$  (MAX5523/MAX54525),  $T_A = +25^\circ C$ , unless otherwise noted.)

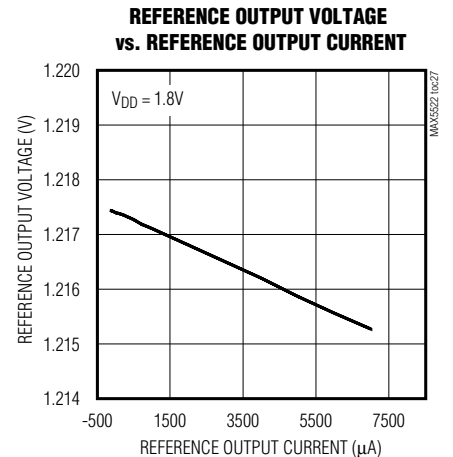
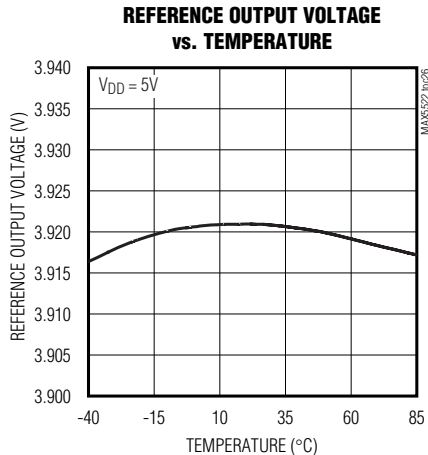
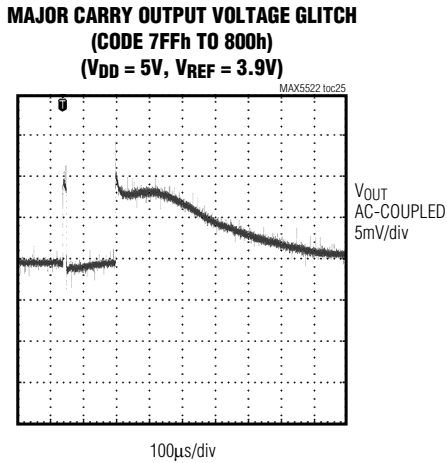
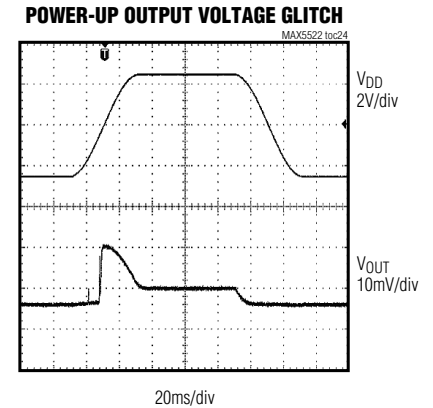
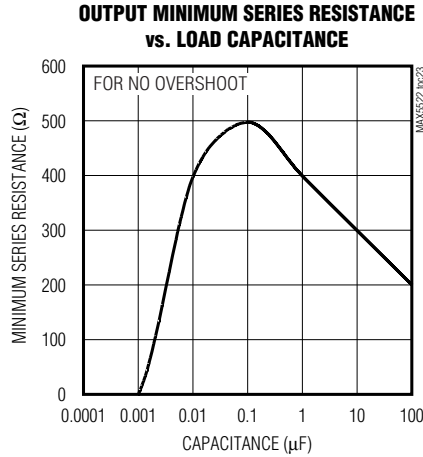
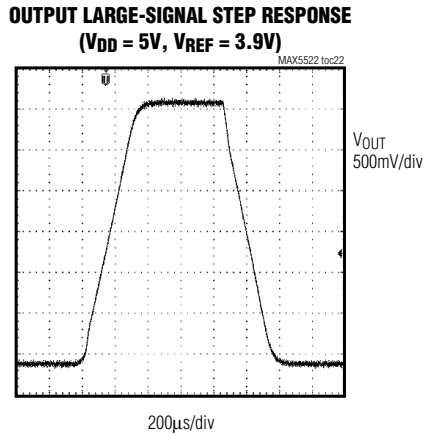
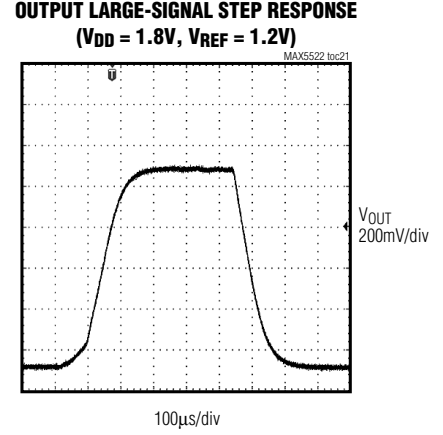
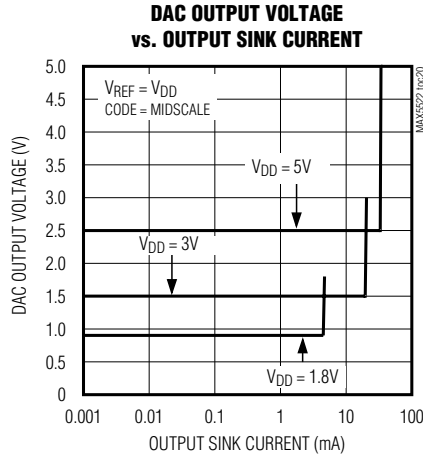
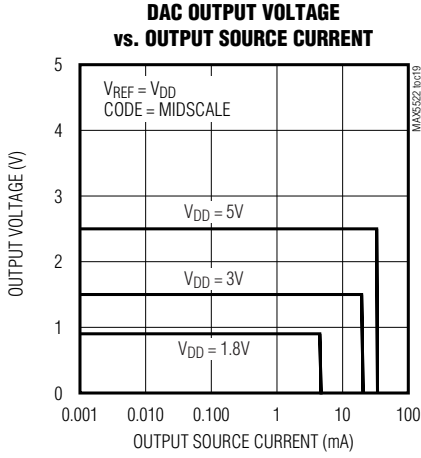

# Dual, Ultra-Low-Power, 10-Bit, Voltage-Output DACs

## Typical Operating Characteristics (continued)

( $V_{DD} = 5.0V$ ,  $V_{REF} = 4.096V$  (MAX5522/MAX5524),  $V_{REF} = 3.9V$  (MAX5523/MAX54525),  $T_A = +25^\circ C$ , unless otherwise noted.)

MAX5522-MAX5525

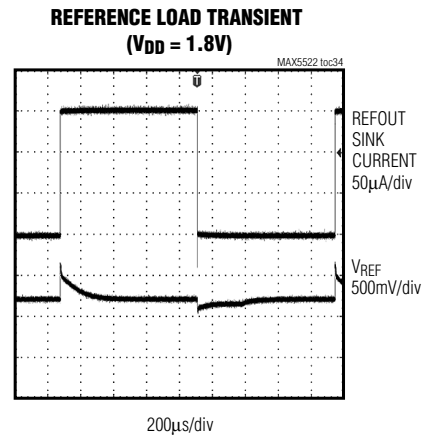
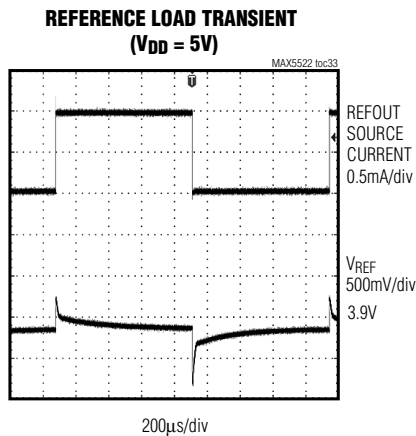
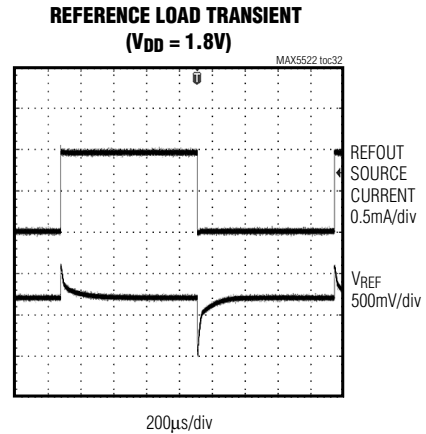
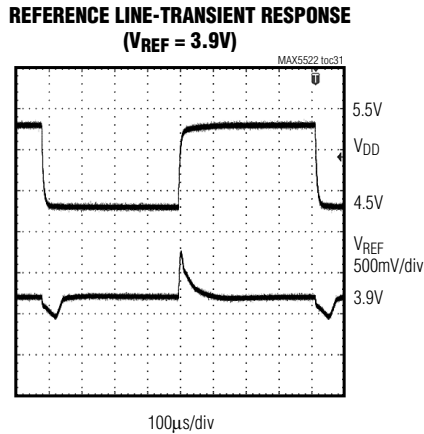
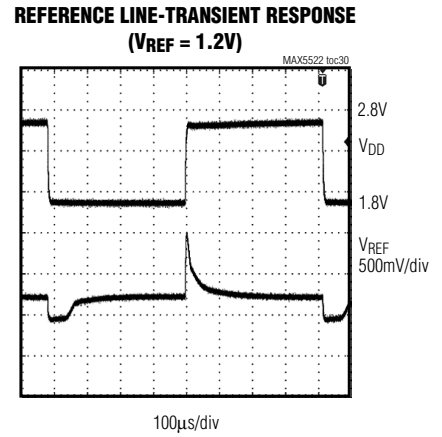
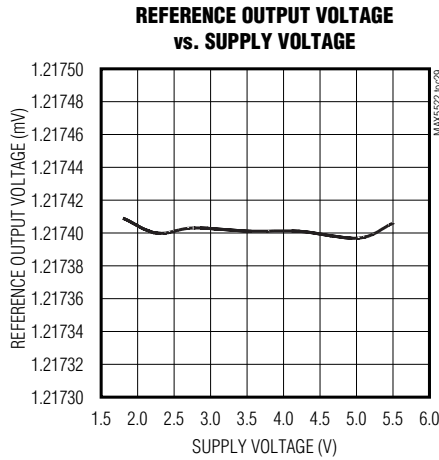
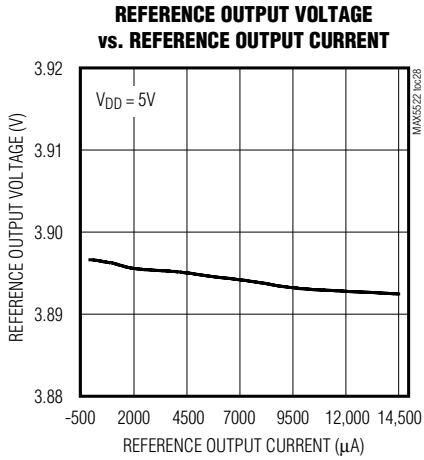



# Dual, Ultra-Low-Power, 10-Bit, Voltage-Output DACs

## Typical Operating Characteristics (continued)

( $V_{DD} = 5.0V$ ,  $V_{REF} = 4.096V$  (MAX5522/MAX5524),  $V_{REF} = 3.9V$  (MAX5523/MAX54525),  $T_A = +25^\circ C$ , unless otherwise noted.)

**REFERENCE LOAD TRANSIENT**  
( $V_{DD} = 5V$ )

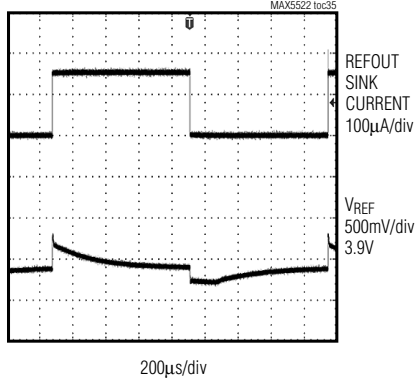

**REFERENCE PSRR vs. FREQUENCY**

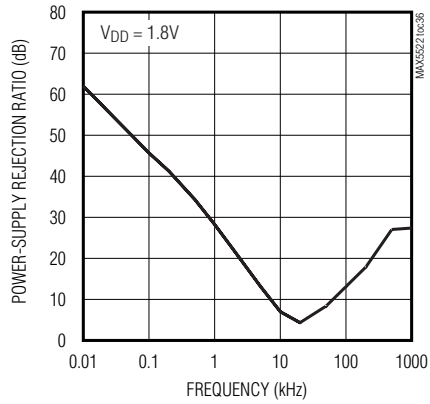

**REFERENCE PSRR vs. FREQUENCY**

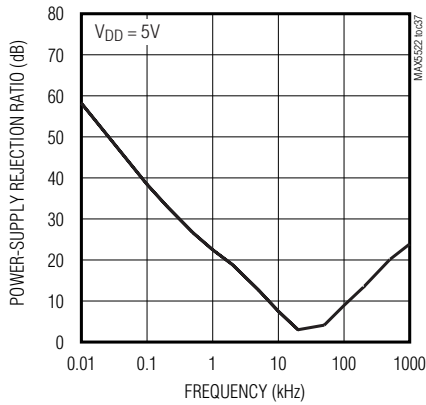

**REFERENCE OUTPUT NOISE**  
(0.1Hz TO 10Hz) ( $V_{DD} = 1.8V$ ,  $V_{REF} = 1.2V$ )

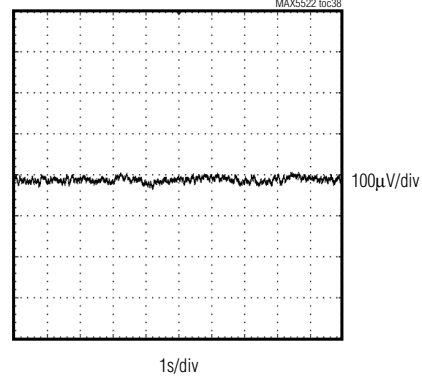

**REFERENCE OUTPUT NOISE**  
(0.1Hz TO 10Hz) ( $V_{DD} = 5V$ ,  $V_{REF} = 3.9V$ )

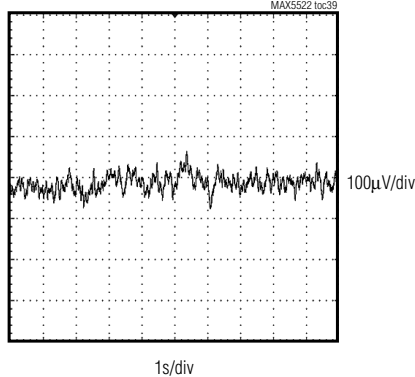

**DAC-TO-DAC CROSSTALK**

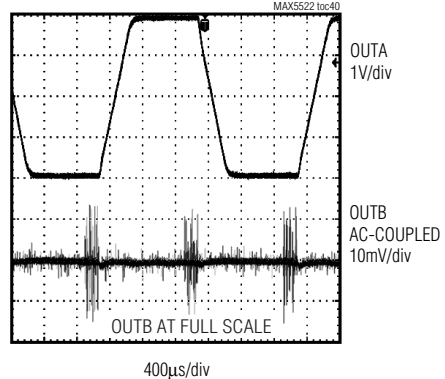

# Dual, Ultra-Low-Power, 10-Bit, Voltage-Output DACs

## Pin Description

| PIN     |         |         |         | NAME            | FUNCTION   |
|---------|---------|---------|---------|-----------------|--|
| MAX5522 | MAX5523 | MAX5524 | MAX5525 |                 |  |
| 1       | 1       | 1       | 1       | $\overline{CS}$ | Active-Low Digital Chip-Select Input   |
| 2       | 2       | 2       | 2       | SCLK            | Serial-Interface Clock Input   |
| 3       | 3       | 3       | 3       | DIN             | Serial-Interface Data Input  |
| 4       | —       | 4       | —       | REFIN           | Reference Input  |
| —       | 4       | —       | 4       | REFOUT          | Reference Output   |
| —       | —       | 5, 11   | 5, 11   | N.C.            | No Connection. Leave N.C. inputs unconnected (floating) or connected to GND.   |
| —       | —       | 6       | 6       | FBB             | Channel B Feedback Input   |
| 5       | 5       | 7       | 7       | OUTB            | Channel B Analog Voltage Output  |
| 6       | 6       | 8       | 8       | V <sub>DD</sub> | Power Input. Connect V <sub>DD</sub> to a 1.8V to 5.5V power supply. Bypass V <sub>DD</sub> to GND with a 0.1μF capacitor. |
| 7       | 7       | 9       | 9       | GND             | Ground   |
| 8       | 8       | 10      | 10      | OUTA            | Channel A Analog Voltage Output  |
| —       | —       | 12      | 12      | FBA             | Channel A Feedback Input   |
| —       | —       | EP      | EP      | Exposed Paddle  | Exposed Paddle. Connect EP to GND.   |

MAX5522-MAX5525

## Functional Diagrams

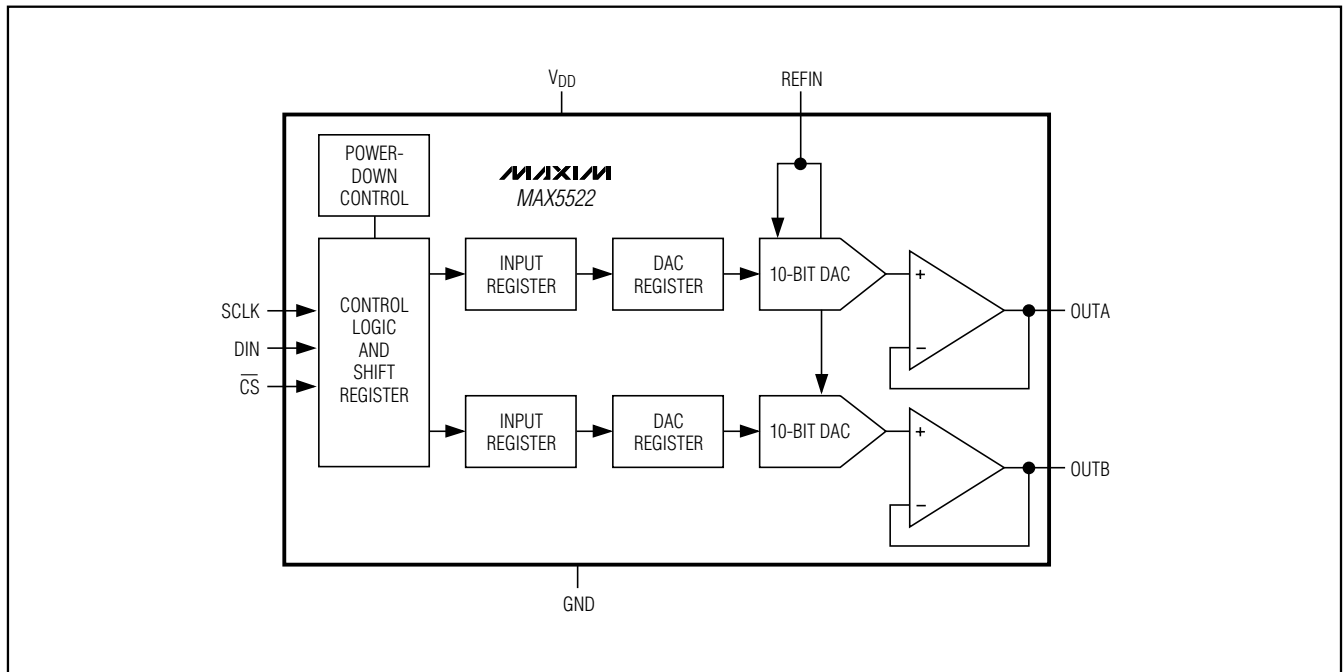

# Dual, Ultra-Low-Power, 10-Bit, Voltage-Output DACs

## Functional Diagrams (continued)

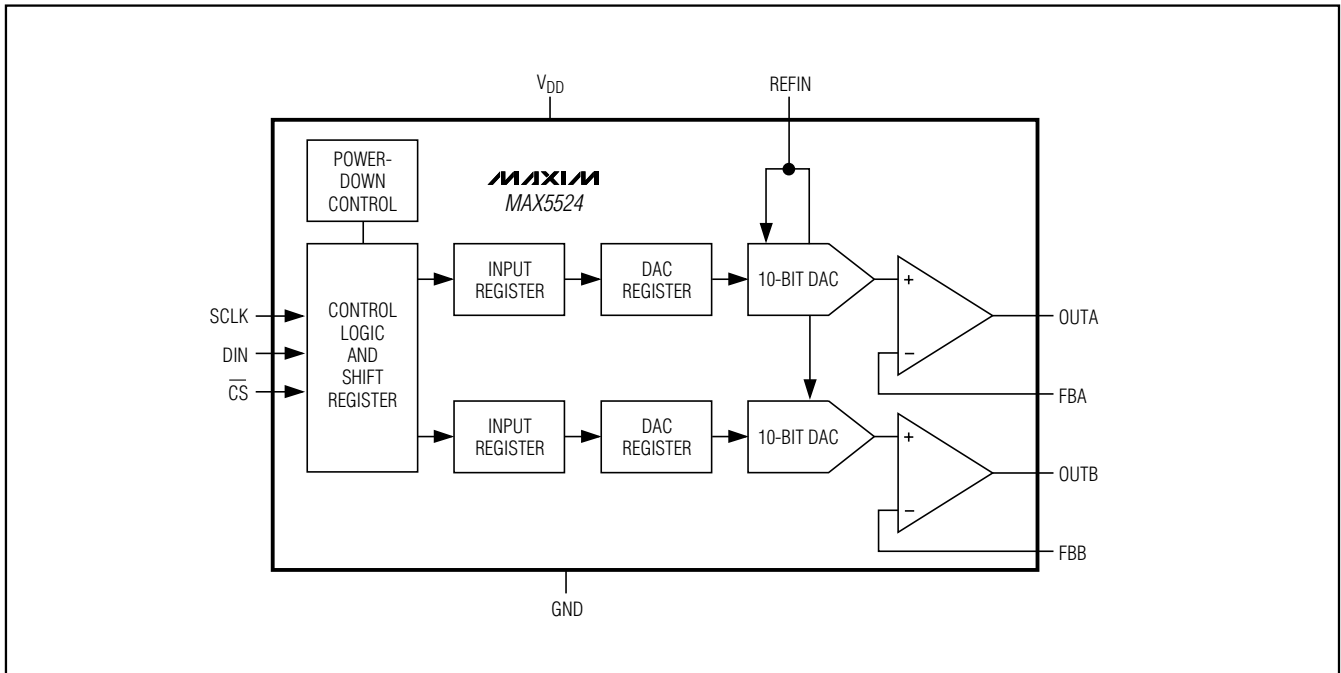
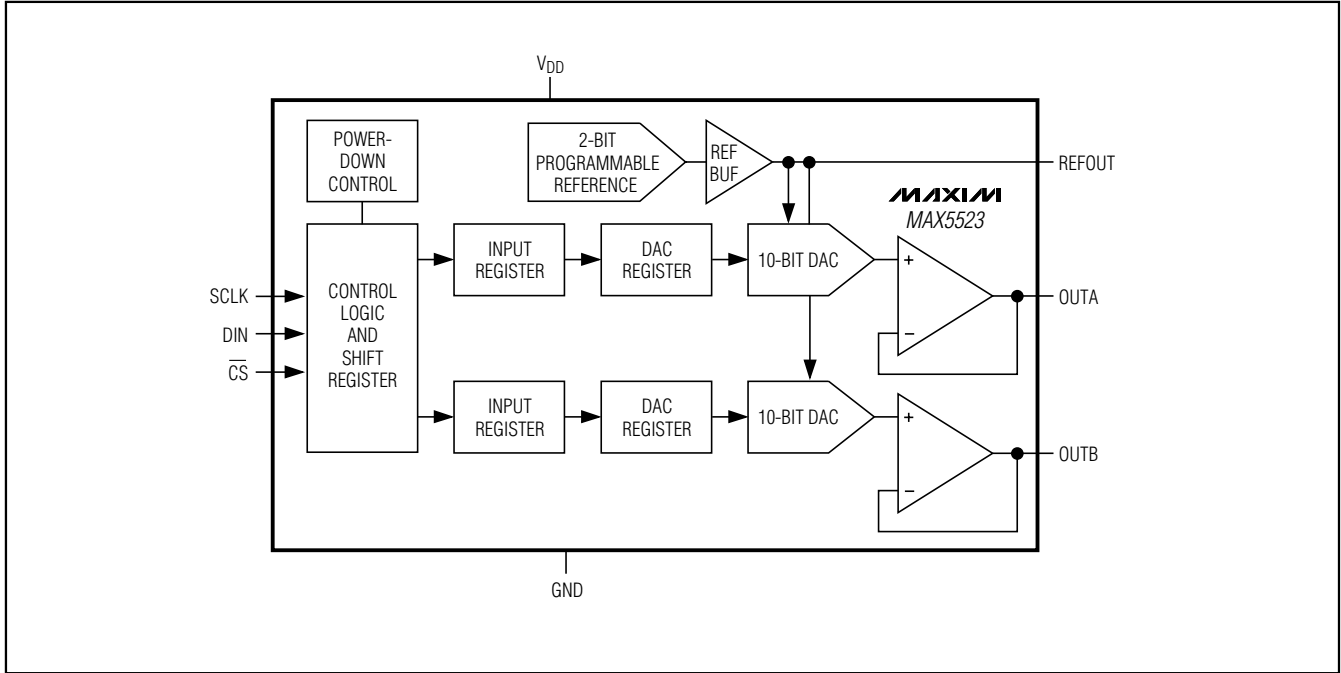

# Dual, Ultra-Low-Power, 10-Bit, Voltage-Output DACs

## Functional Diagrams (continued)

MAX5522-MAX5525

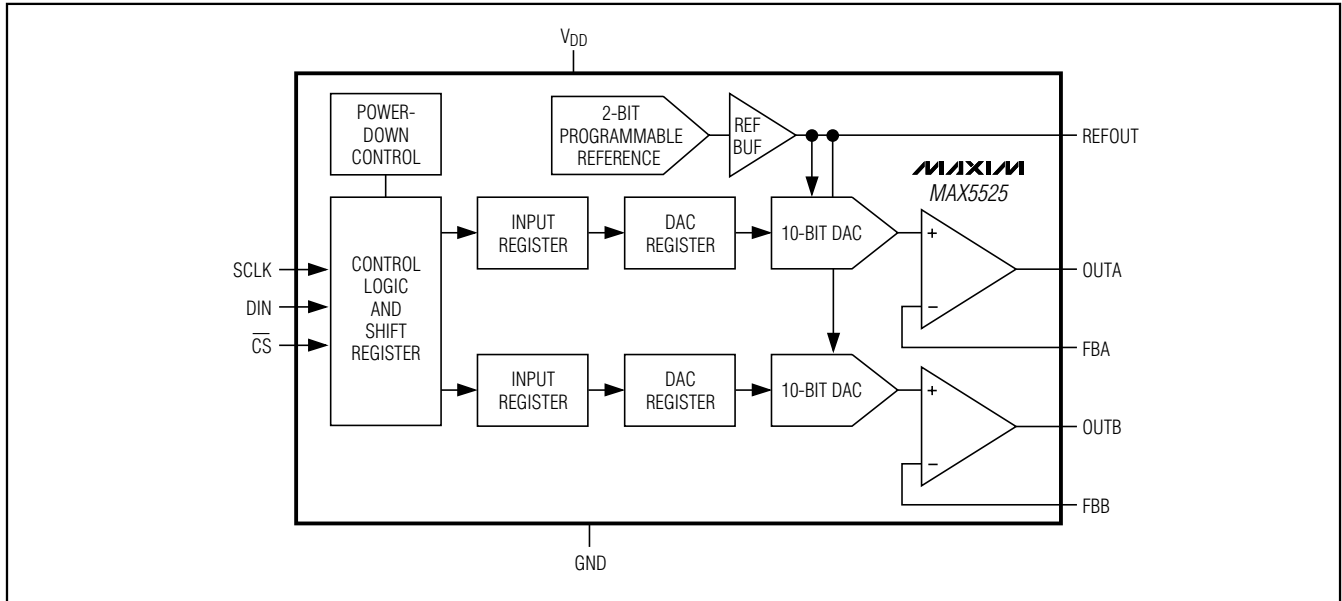

### Detailed Description

The MAX5522–MAX5525 dual, 10-bit, ultra-low-power, voltage-output DACs offer rail-to-rail buffered voltage outputs. The DACs operate from a 1.8V to 5.5V supply and require only 5 $\mu$ A (max) supply current. These devices feature a shutdown mode that reduces overall current, including the reference input current, to just 0.18 $\mu$ A (max). The MAX5523/MAX5525 include an internal reference that saves additional board space and can source up to 8mA, making it functional as a system reference. The 16MHz, 3-wire serial interface is compatible with SPI, QSPI, and MICROWIRE protocols. When  $V_{DD}$  is applied, all DAC outputs are driven to zero scale with virtually no output glitch. The MAX5522/MAX5523 output buffers are configured in unity gain and come in  $\mu$ MAX packages. The MAX5524/MAX5525 output buffers are configured in force sense allowing users to externally set voltage gains on the output (an output-amplifier inverting input is available). The MAX5524/MAX5525 come in 4mm x 4mm thin QFN packages.

### Digital Interface

The MAX5522–MAX5525 use a 3-wire serial interface that is compatible with SPI/QSPI/MICROWIRE protocols (Figures 1 and 2).

The MAX5522–MAX5525 include a single, 16-bit, input shift register. Data loads into the shift register through the serial interface.  $\overline{CS}$  must remain low until all 16 bits are clocked in. The 16 bits consist of 4 control bits (C3–C0), 10 data bits (D9–D0) (Table 1), and 2 sub-bits (S1 and S0). D9–D0 are the DAC data bits and S1 and S0 are the sub-bits. The sub-bits must be set to zero for proper operation. Following the control bits, data loads MSB first, D9–D0. The control bits C3–C0 control the MAX5522–MAX5525, as outlined in Table 2.

Each DAC channel includes two registers: an input register and a DAC register. The input register holds input data. The DAC register contains the data updated to the DAC output.

The double-buffered register configuration allows any of the following:

- Loading the input registers without updating the DAC registers
- Updating the DAC registers from the input registers
- Updating all the input and DAC registers simultaneously

# Dual, Ultra-Low-Power, 10-Bit, Voltage-Output DACs

**Table 1. Serial Write Data Format**

| CONTROL |    |    |    | DATA BITS |    |    |    |    |    |    |    |    |    |    |    |     |  |
|---------|----|----|----|-----------|----|----|----|----|----|----|----|----|----|----|----|-----|--|
| MSB     |    |    |    |           |    |    |    |    |    |    |    |    |    |    |    | LSB |  |
| C3      | C2 | C1 | C0 | D9        | D8 | D7 | D6 | D5 | D4 | D3 | D2 | D1 | D0 | S1 | S0 |     |  |

*Sub-bits S1 to S0 must be set to zero for proper operation.*

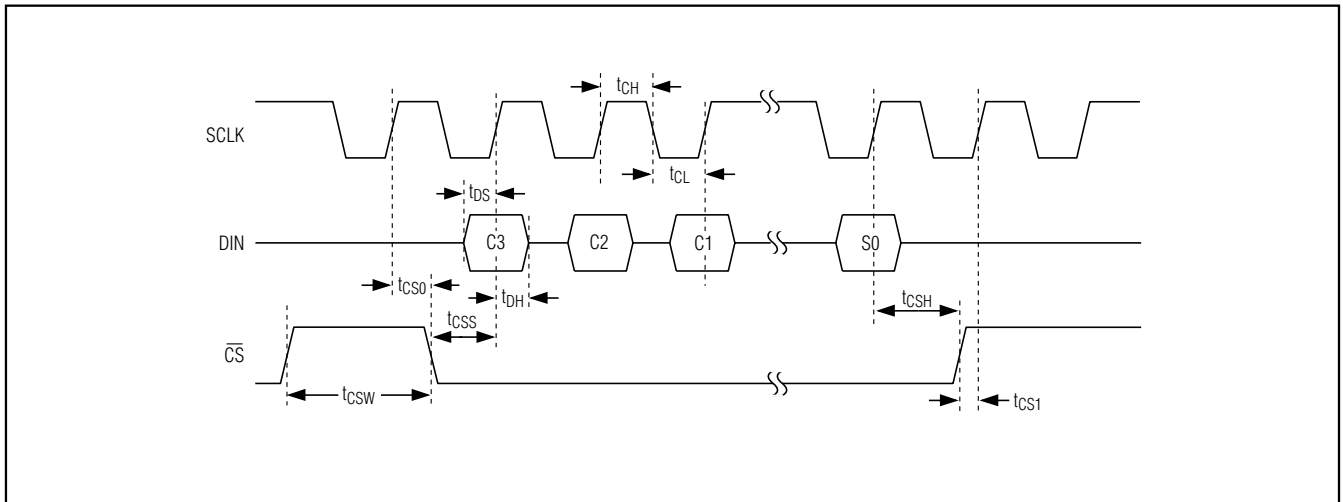

Figure 1. Timing Diagram

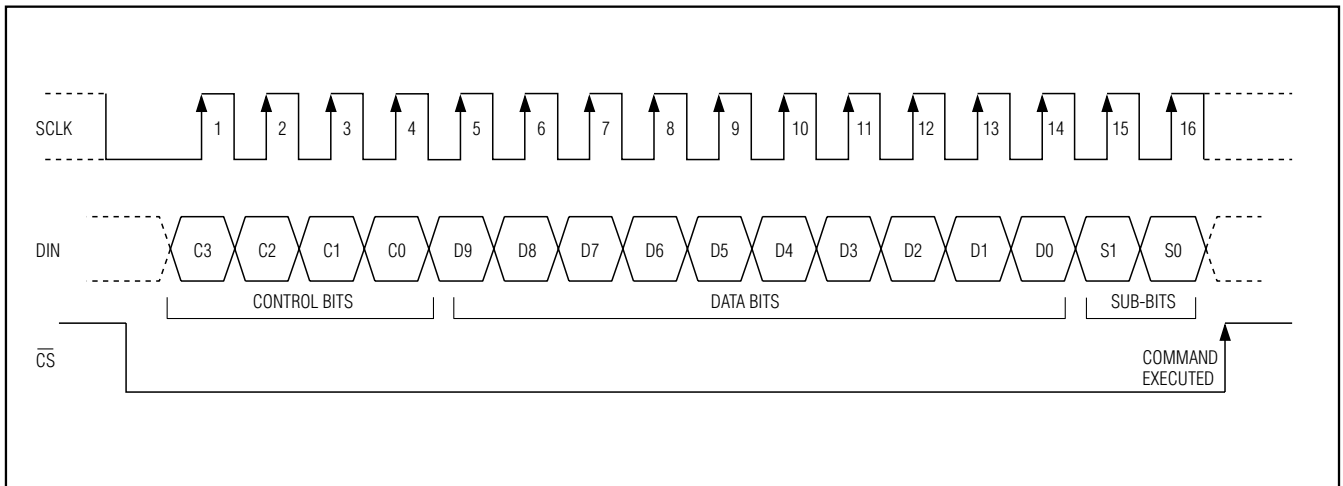

Figure 2. Register Loading Diagram

# Dual, Ultra-Low-Power, 10-Bit, Voltage-Output DACs

MAX5522-MAX5525

**Table 2. Serial-Interface Programming Commands**

| CONTROL BITS |    |    |    | INPUT DATA            | SUB-BITS  | FUNCTION  |
|--------------|----|----|----|-----------------------|-----------|---|
| C3           | C2 | C1 | C0 | D9–D0                 | S1 AND S0 |   |
| 0            | 0  | 0  | 0  | XXXXXXXXXX            | 00        | No operation; command is ignored.   |
| 0            | 0  | 0  | 1  | 10-bit data           | 00        | Load input register A from shift register; DAC registers unchanged; DAC outputs unchanged.  |
| 0            | 0  | 1  | 0  | 10-bit data           | 00        | Load input register B from shift register; DAC registers unchanged; DAC outputs unchanged.  |
| 0            | 0  | 1  | 1  | —                     | —         | Command reserved. Do not use.   |
| 0            | 1  | 0  | 0  | —                     | —         | Command reserved. Do not use.   |
| 0            | 1  | 0  | 1  | —                     | —         | Command reserved. Do not use.   |
| 0            | 1  | 1  | 0  | —                     | —         | Command reserved. Do not use.   |
| 0            | 1  | 1  | 1  | —                     | —         | Command reserved. Do not use.   |
| 1            | 0  | 0  | 0  | 10-bit data           | 00        | Load DAC registers A and B from respective input registers; DAC outputs A and B updated; MAX5523/MAX5525 enter normal operation if in standby or shutdown; MAX5522/MAX5524 enter normal operation if in shutdown.   |
| 1            | 0  | 0  | 1  | 10-bit data           | 00        | Load input register A and DAC register A from shift register; DAC output A updated; Load DAC register B from input register B; DAC output B updated; MAX5523/MAX5525 enter normal operation if in standby or shutdown; MAX5522/MAX5524 enter normal operation if in shutdown. |
| 1            | 0  | 1  | 0  | 10-bit data           | 00        | Load input register B and DAC register B from shift register; DAC output B updated; Load DAC register A from input register A; DAC output A updated; MAX5523/MAX5525 enter normal operation if in standby or shutdown; MAX5522/MAX5524 enter normal operation if in shutdown. |
| 1            | 0  | 1  | 1  | —                     | —         | Command reserved. Do not use.   |
| 1            | 1  | 0  | 0  | D9, D8,<br>XXXXXXXXXX | 00        | MAX5523/MAX5525 enter standby*, MAX5522/MAX5524 enter shutdown. For the MAX5523/MAX5525, D9 and D8 configure the internal reference voltage (Table 3).  |
| 1            | 1  | 0  | 1  | D9, D8,<br>XXXXXXXXXX | 00        | MAX5522–MAX5525 enter normal operation; DAC outputs reflect existing contents of DAC registers. For the MAX5523/MAX5525, D9 and D8 configure the internal reference voltage (Table 3).  |
| 1            | 1  | 1  | 0  | D9, D8,<br>XXXXXXXXXX | 00        | MAX5522–MAX5525 enter shutdown; DAC outputs set to high impedance. For the MAX5523/MAX5525, D9 and D8 configure the internal reference voltage (Table 3).   |
| 1            | 1  | 1  | 1  | 10-bit data           | 00        | Load input registers A and B and DAC registers A and B from shift register; DAC outputs A and B updated; MAX5523/MAX5525 enter normal operation if in standby or shutdown; MAX5522/MAX5524 enter normal operation if in shutdown.   |

X = Don't care.

\*Standby mode can be entered from normal operation only. It is not possible to enter standby mode from shutdown.

# Dual, Ultra-Low-Power, 10-Bit, Voltage-Output DACs

## Power Modes

The MAX5522–MAX5525 feature two power modes to conserve power during idle periods. In normal operation, the device is fully operational. In shutdown mode, the device is completely powered down, including the internal voltage reference in the MAX5523/MAX5525. The MAX5523/MAX5525 also offer a standby mode in which all circuitry is powered down except the internal voltage reference. Standby mode keeps the reference powered up while the remaining circuitry is shut down, allowing it to be used as a system reference. It also helps reduce the wake-up delay by not requiring the reference to power up when returning to normal operation.

## Shutdown Mode

The MAX5522–MAX5525 feature a software-programmable shutdown mode that reduces the supply current and the interface input-current to 0.18μA (max). Writing an input control word with control bits C[3:0] = 1110 (Table 2) places the device in shutdown mode. In shutdown, the MAX5522/MAX5524 reference input and DAC output buffers go high impedance. Placing the MAX5523/MAX5525 into shutdown turns off the internal reference and the DAC output buffers go high impedance. The serial interface still remains active for all devices.

Table 2 shows several commands that bring the MAX5522–MAX5525 back to normal operation. The power-up time from shutdown is required before the DAC outputs are valid.

**Note:** For the MAX5523/MAX5525, standby mode cannot be entered directly from shutdown mode. The device must be brought into normal operation first before entering standby mode.

## Standby Mode (MAX5523/MAX5525 Only)

The MAX5523/MAX5525 feature a software-programmable standby mode that reduces the typical supply current to 3μA (max). Standby mode powers down all circuitry except the internal voltage reference. Place the device in standby mode by writing an input control word with control bits C[3:0] = 1100 (Table 2). The internal reference and serial interface remain active while the DAC output buffers go high impedance.

For the MAX5523/MAX5525, standby mode cannot be entered directly from shutdown mode. The device must be brought into normal operation first before entering standby mode. To enter standby from shutdown, issue the command to return to normal operation followed immediately by the command to go into standby.

Table 2 shows several commands that bring the MAX5523/MAX5525 back to normal operation. When transitioning from standby mode to normal operation, only the DAC power-up time is required before the DAC outputs are valid.

## Reference Input

The MAX5522/MAX5524 accept a reference with a voltage range extending from 0 to V<sub>DD</sub>. The output voltage (V<sub>OUT</sub>) is represented by a digitally programmable voltage source as:

$$V_{OUT} = (V_{REF} \times N / 256) \times \text{gain}$$

where N is the numeric value of the DAC's binary input code (0 to 1023), V<sub>REF</sub> is the reference voltage, gain is the externally set voltage gain for the MAX5524, and gain is one for the MAX5522.

In shutdown mode, the reference input enters a high-impedance state with an input impedance of 2.5GΩ (typ).

## Reference Output

The MAX5523/MAX5525 internal voltage reference is software configurable to one of four voltages. Upon power-up, the default reference voltage is 1.214V. Configure the reference voltage using D8 and D9 data bits (Table 3) when the control bits are as follows C[3:0] = 1100, 1101, or 1110 (Table 2). V<sub>DD</sub> must be kept at a minimum of 200mV above V<sub>REF</sub> for proper operation.

**Table 3. Reference Output Voltage Programming**

| D9 | D8 | REFERENCE VOLTAGE (V) |
|----|----|-----------------------|
| 0  | 0  | 1.214                 |
| 0  | 1  | 1.940                 |
| 1  | 0  | 2.425                 |
| 1  | 1  | 3.885                 |

# Dual, Ultra-Low-Power, 10-Bit, Voltage-Output DACs

MAX5522-MAX5525

## Applications Information

### 1-Cell and 2-Cell Circuits

See Figure 3 for an illustration of how to power the MAX5522–MAX5525 with either one lithium-ion battery or two alkaline batteries. The low current consumption of the devices make the MAX5522–MAX5525 ideal for battery-powered applications.

### Programmable Current Source

See the circuit in Figure 4 for an illustration of how to configure the MAX5524/MAX5525 as a programmable current source for driving an LED. The MAX5524/MAX5525 drive a standard NPN transistor to program the current source. The current source ( $I_{LED}$ ) is defined in the equation in Figure 4.

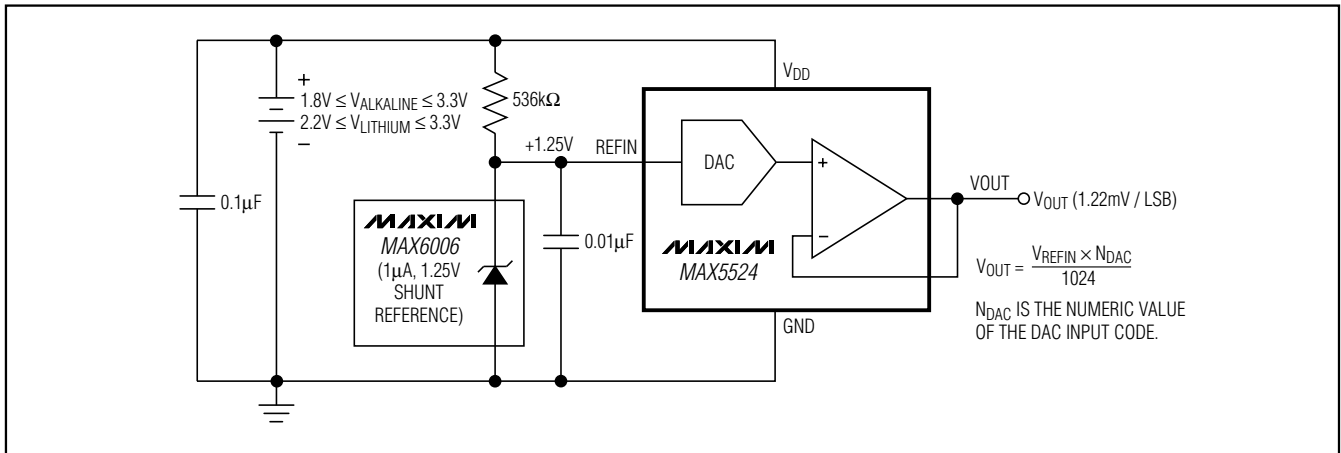

Figure 3. Portable Application Using Two Alkaline Cells or One Lithium Coin Cell

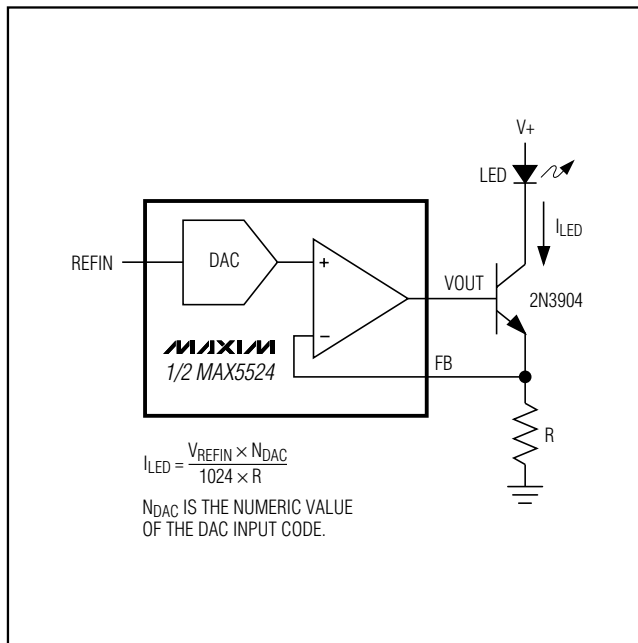

Figure 4. Programmable Current Source Driving an LED

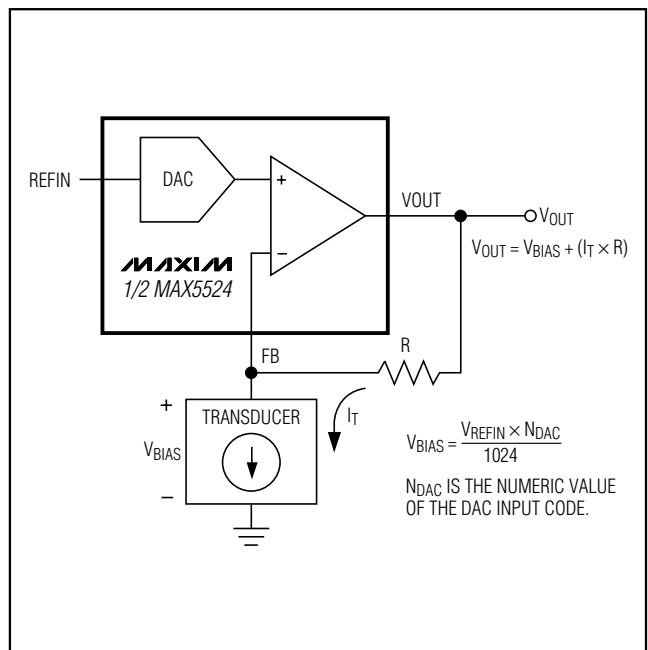

Figure 5. Transimpedance Configuration for a Voltage-Biased Current-Output Transducer



# Dual, Ultra-Low-Power, 10-Bit, Voltage-Output DACs

## Voltage Biasing a Current-Output Transducer

See the circuit in Figure 5 for an illustration of how to configure the MAX5524/MAX5525 to bias a current-output transducer. In Figure 5, the output voltage of the MAX5524/MAX5525 is a function of the voltage drop across the transducer added to the voltage drop across the feedback resistor R.

## Unipolar Output

Figure 6 shows the MAX5524 in a unipolar output configuration with unity gain. Table 4 lists the unipolar output codes.

## Bipolar Output

The MAX5524 output can be configured for bipolar operation as shown in Figure 7. The output voltage is given by the following equation:

$$V_{OUT\_} = V_{REFIN} \times [(N_A - 512) / 512]$$

where  $N_A$  represents the decimal value of the DAC's binary input code. Table 5 shows the digital codes (offset binary) and the corresponding output voltage for the circuit in Figure 7.

## Configurable Output Gain

The MAX5524/MAX5525 have force-sense outputs, which provide a connection directly to the inverting terminal of the output op amp, yielding the most flexibility. The advantage of the force-sense output is that specific gains can be set externally for a given application. The gain error for the MAX5524/MAX5525 is specified in a unity-gain configuration (op-amp output and inverting terminals connected), and additional gain error results from external resistor tolerances. Another advantage of the force-sense DAC is that it allows many useful circuits to be created with only a few simple external components.

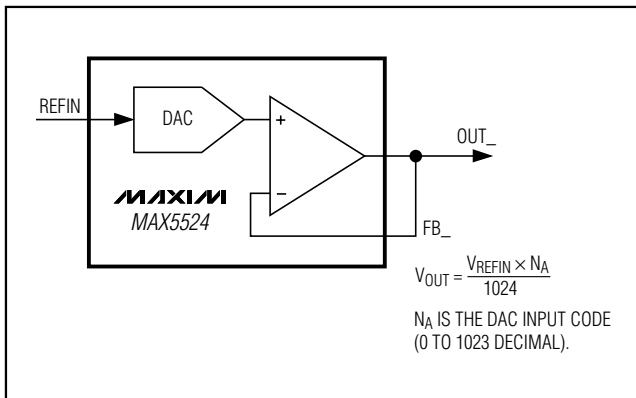

Figure 6. Unipolar Output Circuit

An example of a custom fixed gain using the MAX5524/MAX5525 force-sense output is shown in Figure 8. In this example, R1 and R2 set the gain for  $V_{OUTA}$ .

$$V_{OUTA} = [(V_{REFIN} \times N_A) / 1024] \times [1 + (R2 / R1)]$$

where  $N_A$  represents the numeric value of the DAC input code.

## Self-Biased Two-Electrode Potentiostat Application

See the circuit in Figure 10 for an illustration of how to use the MAX5525 to bias a two-electrode potentiostat on the input of an ADC.

## Power Supply and Bypassing Considerations

Bypass the power supply with a 4.7µF capacitor in parallel with a 0.1µF capacitor to GND. Minimize lengths to reduce lead inductance. If noise becomes an issue, use shielding and/or ferrite beads to increase isolation. For the thin QFN package, connect the exposed pad to ground.

Table 4. Unipolar Code Table (Gain = +1)

| DAC CONTENTS |      |      | ANALOG OUTPUT              |
|--------------|------|------|----------------------------|
| MSB          | LSB  |      |                            |
| 1111         | 1111 | 1100 | +VREF (1023/1024)          |
| 1000         | 0000 | 0100 | +VREF (513/1024)           |
| 1000         | 0000 | 0000 | +VREF (512/1024) = +VREF/2 |
| 0111         | 1111 | 1100 | +VREF (511/1024)           |
| 0000         | 0000 | 0100 | +VREF (1/1024)             |
| 0000         | 0000 | 0000 | 0V                         |

Table 5. Bipolar Code Table (Gain = +1)

| DAC CONTENTS |      |      | ANALOG OUTPUT           |
|--------------|------|------|-------------------------|
| MSB          | LSB  |      |                         |
| 1111         | 1111 | 1100 | +VREF (511/512)         |
| 1000         | 0000 | 0100 | +VREF (1/512)           |
| 1000         | 0000 | 0000 | 0V                      |
| 0111         | 1111 | 1100 | -VREF (1/512)           |
| 0000         | 0000 | 0100 | -VREF (511/512)         |
| 0000         | 0000 | 0000 | -VREF (512/512) = -VREF |

# Dual, Ultra-Low-Power, 10-Bit, Voltage-Output DACs

MAX5522-MAX5525

## Layout Considerations

Digital and AC transient signals coupling to GND can create noise at the output. Use proper grounding techniques, such as a multilayer board with a low-inductance ground plane. Wire-wrapped boards and sockets are not recommended. For optimum system performance, use printed circuit (PC) boards. Good PC board ground layout minimizes crosstalk between DAC outputs, reference inputs, and digital inputs. Reduce crosstalk by keeping analog lines away from digital lines.

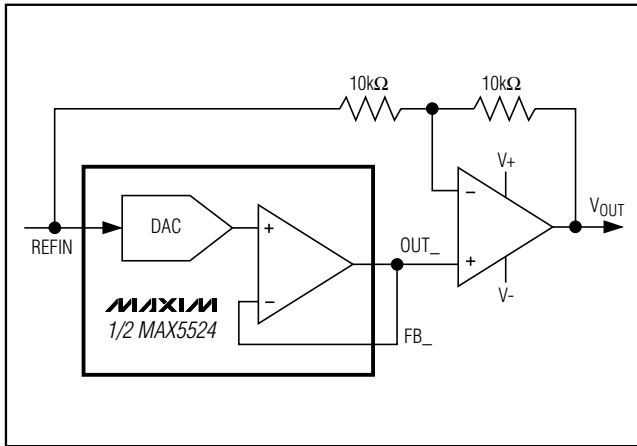

Figure 7. Bipolar Output Circuit

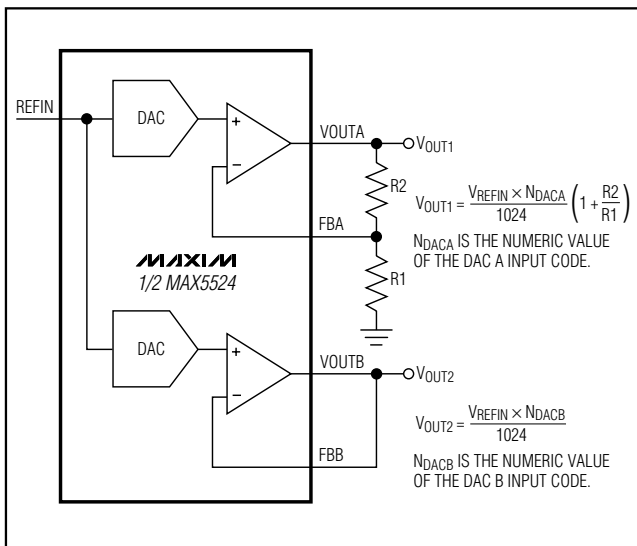

Figure 8. Separate Force-Sense Outputs Create Unity and Greater-than-Unity DAC Gains Using the Same Reference

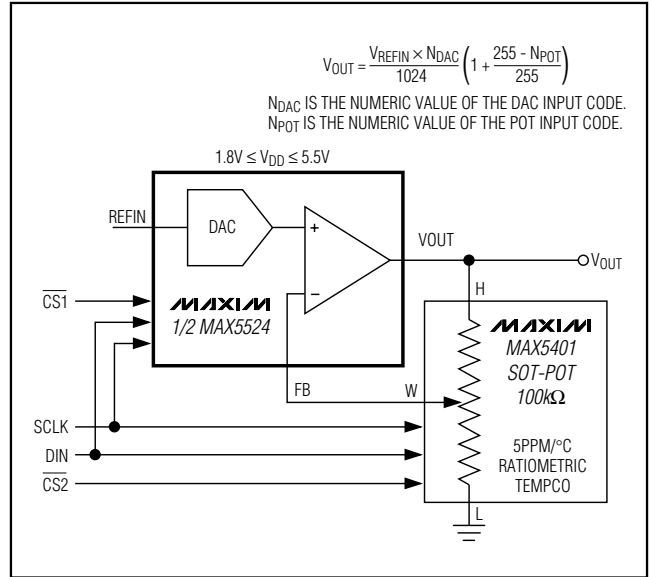

Figure 9. Software-Configurable Output Gain

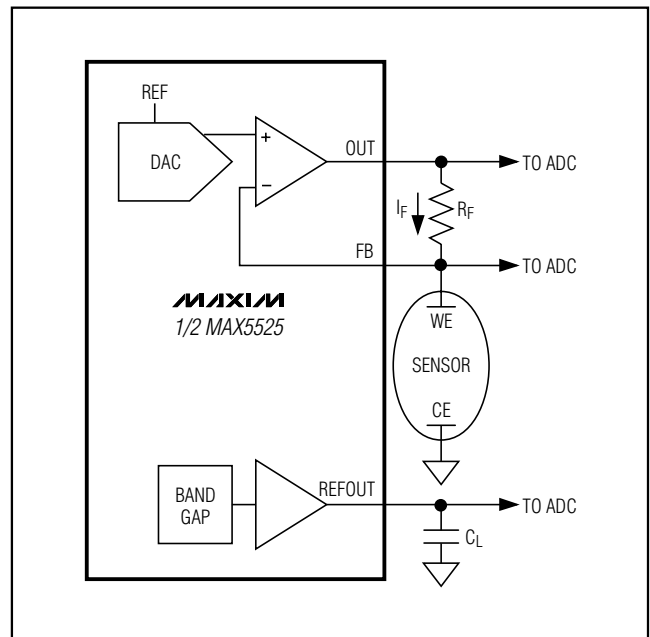

Figure 10. Self-Biased Two-Electrode Potentiostat Application

# Dual, Ultra-Low-Power, 10-Bit, Voltage-Output DACs

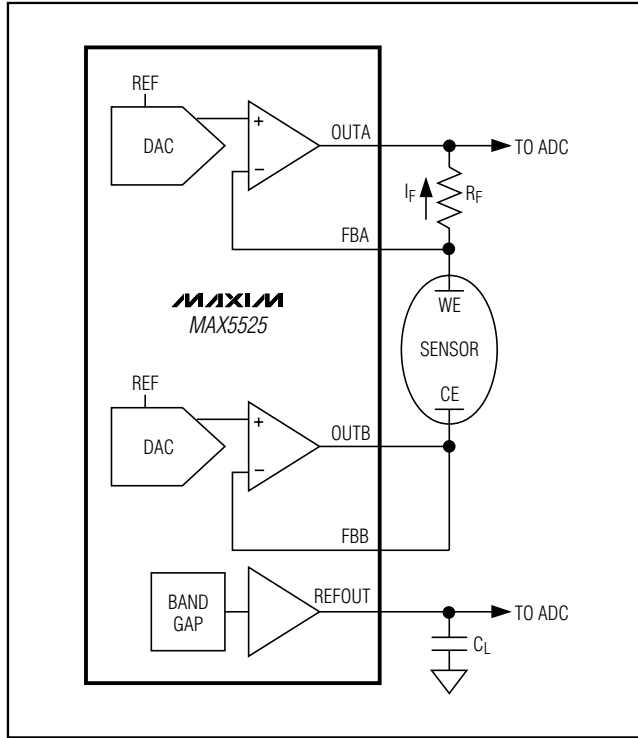
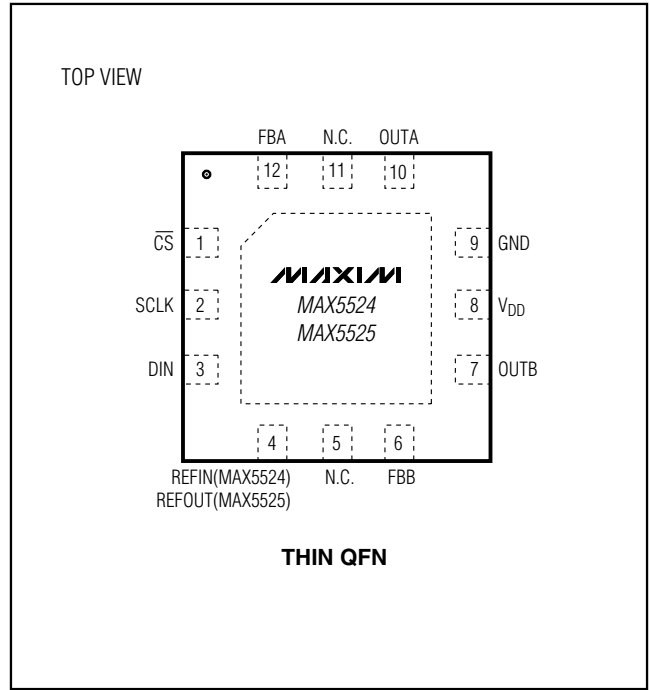

Figure 11. Driven Two-Electrode Potentiostat Application

## Pin Configurations (continued)



## Chip Information

TRANSISTOR COUNT: 10,688  
 PROCESS: BiCMOS

# Dual, Ultra-Low-Power, 10-Bit, Voltage-Output DACs

## Package Information

(The package drawing(s) in this data sheet may not reflect the most current specifications. For the latest package outline information, go to [www.maxim-ic.com/packages](http://www.maxim-ic.com/packages).)

MAX5522-MAX5525

24L QFN THIN.EPS

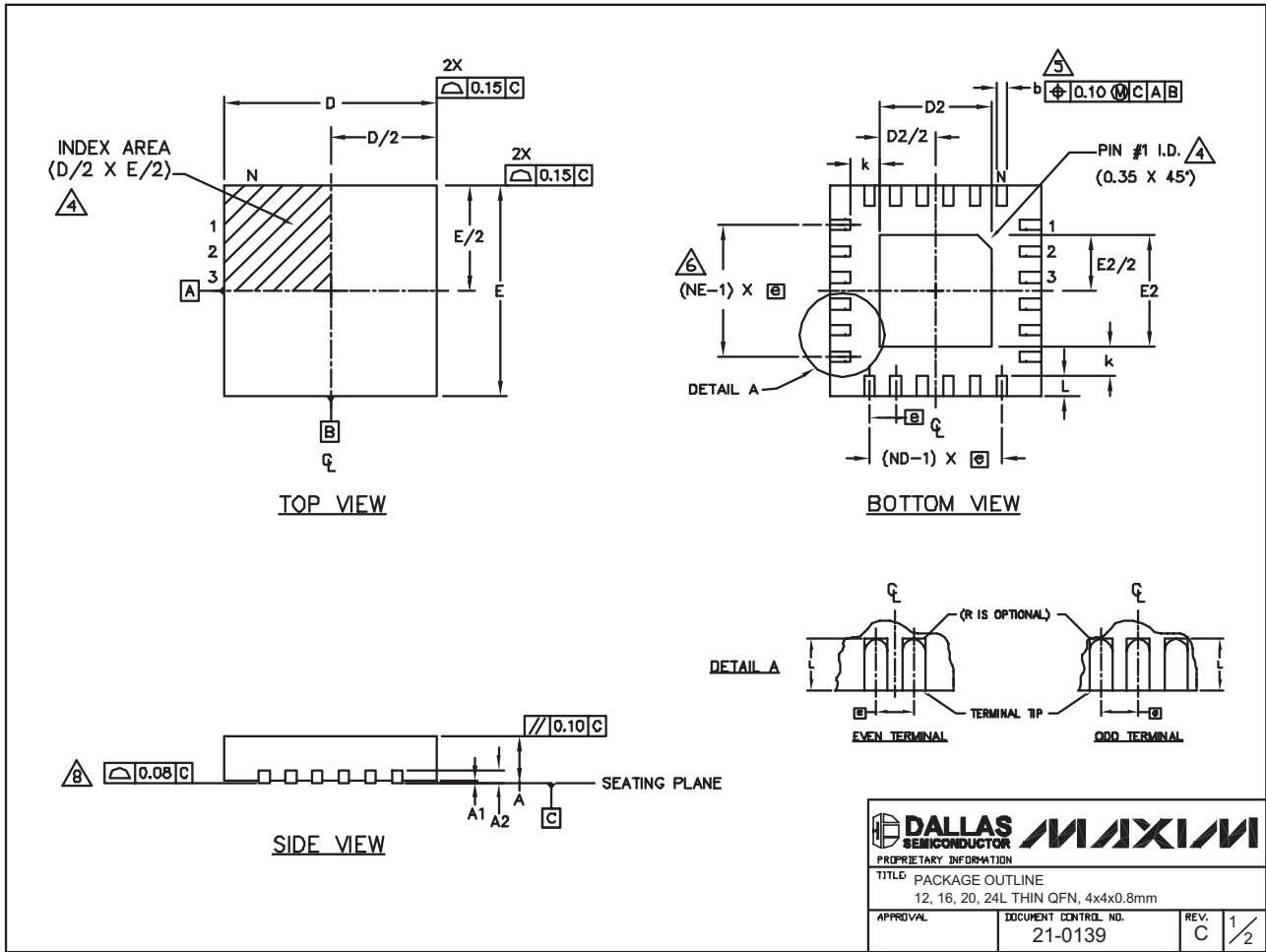

# Dual, Ultra-Low-Power, 10-Bit, Voltage-Output DACs

## Package Information (continued)

(The package drawing(s) in this data sheet may not reflect the most current specifications. For the latest package outline information, go to [www.maxim-ic.com/packages](http://www.maxim-ic.com/packages).)

| COMMON DIMENSIONS |           |      |      |           |      |      |           |      |      |           |      |      |
|-------------------|-----------|------|------|-----------|------|------|-----------|------|------|-----------|------|------|
| PKG REF.          | 12L 4x4   |      |      | 16L 4x4   |      |      | 20L 4x4   |      |      | 24L 4x4   |      |      |
|                   | MIN.      | NOM. | MAX. | MIN.      | NOM. | MAX. | MIN.      | NOM. | MAX. | MIN.      | NOM. | MAX. |
| A                 | 0.70      | 0.75 | 0.80 | 0.70      | 0.75 | 0.80 | 0.70      | 0.75 | 0.80 | 0.70      | 0.75 | 0.80 |
| A1                | 0.0       | 0.02 | 0.05 | 0.0       | 0.02 | 0.05 | 0.0       | 0.02 | 0.05 | 0.0       | 0.02 | 0.05 |
| A2                | 0.20 REF  |      |      | 0.20 REF  |      |      | 0.20 REF  |      |      | 0.20 REF  |      |      |
| b                 | 0.25      | 0.30 | 0.35 | 0.25      | 0.30 | 0.35 | 0.20      | 0.25 | 0.30 | 0.18      | 0.23 | 0.30 |
| D                 | 3.90      | 4.00 | 4.10 | 3.90      | 4.00 | 4.10 | 3.90      | 4.00 | 4.10 | 3.90      | 4.00 | 4.10 |
| E                 | 3.90      | 4.00 | 4.10 | 3.90      | 4.00 | 4.10 | 3.90      | 4.00 | 4.10 | 3.90      | 4.00 | 4.10 |
| e                 | 0.80 BSC. |      |      | 0.65 BSC. |      |      | 0.50 BSC. |      |      | 0.50 BSC. |      |      |
| k                 | 0.25      | -    | -    | 0.25      | -    | -    | 0.25      | -    | -    | 0.25      | -    | -    |
| L                 | 0.45      | 0.55 | 0.65 | 0.45      | 0.55 | 0.65 | 0.45      | 0.55 | 0.65 | 0.30      | 0.40 | 0.50 |
| N                 | 12        |      |      | 16        |      |      | 20        |      |      | 24        |      |      |
| ND                | 3         |      |      | 4         |      |      | 5         |      |      | 6         |      |      |
| NE                | 3         |      |      | 4         |      |      | 5         |      |      | 6         |      |      |
| JeDEC Vgr.        | WGGB      |      |      | WGGC      |      |      | WGGD-1    |      |      | WGGD-2    |      |      |

| EXPOSED PAD VARIATIONS |      |      |      |      |      |      |                    |
|------------------------|------|------|------|------|------|------|--------------------|
| PKG. CODES             | D2   |      |      | E2   |      |      | DOWN BONDS ALLOWED |
|                        | MIN. | NOM. | MAX. | MIN. | NOM. | MAX. |                    |
| T1244-2                | 1.95 | 2.10 | 2.25 | 1.95 | 2.10 | 2.25 | NO                 |
| T1244-3                | 1.95 | 2.10 | 2.25 | 1.95 | 2.10 | 2.25 | YES                |
| T1244-4                | 1.95 | 2.10 | 2.25 | 1.95 | 2.10 | 2.25 | NO                 |
| T1644-2                | 1.95 | 2.10 | 2.25 | 1.95 | 2.10 | 2.25 | NO                 |
| T1644-3                | 1.95 | 2.10 | 2.25 | 1.95 | 2.10 | 2.25 | YES                |
| T1644-4                | 1.95 | 2.10 | 2.25 | 1.95 | 2.10 | 2.25 | NO                 |
| T2044-1                | 1.95 | 2.10 | 2.25 | 1.95 | 2.10 | 2.25 | NO                 |
| T2044-2                | 1.95 | 2.10 | 2.25 | 1.95 | 2.10 | 2.25 | YES                |
| T2044-3                | 1.95 | 2.10 | 2.25 | 1.95 | 2.10 | 2.25 | NO                 |
| T2444-1                | 2.45 | 2.60 | 2.63 | 2.45 | 2.60 | 2.63 | NO                 |
| T2444-2                | 1.95 | 2.10 | 2.25 | 1.95 | 2.10 | 2.25 | YES                |
| T2444-3                | 2.45 | 2.60 | 2.63 | 2.45 | 2.60 | 2.63 | YES                |
| T2444-4                | 2.45 | 2.60 | 2.63 | 2.45 | 2.60 | 2.63 | NO                 |

**NOTES:**

- DIMENSIONING & TOLERANCING CONFORM TO ASME Y14.5M-1994.
- ALL DIMENSIONS ARE IN MILLIMETERS. ANGLES ARE IN DEGREES.
- N IS THE TOTAL NUMBER OF TERMINALS.
- THE TERMINAL #1 IDENTIFIER AND TERMINAL NUMBERING CONVENTION SHALL CONFORM TO JEDEC 95-1 SPP-012. DETAILS OF TERMINAL #1 IDENTIFIER ARE OPTIONAL, BUT MUST BE LOCATED WITHIN THE ZONE INDICATED. THE TERMINAL #1 IDENTIFIER MAY BE EITHER A MOLD OR MARKED FEATURE.
- DIMENSION b APPLIES TO METALLIZED TERMINAL AND IS MEASURED BETWEEN 0.25 mm AND 0.30 mm FROM TERMINAL TIP.
- ND AND NE REFER TO THE NUMBER OF TERMINALS ON EACH D AND E SIDE RESPECTIVELY.
- DEPOPULATION IS POSSIBLE IN A SYMMETRICAL FASHION.
- COPLANARITY APPLIES TO THE EXPOSED HEAT SINK SLUG AS WELL AS THE TERMINALS.
- DRAWING CONFORMS TO JEDEC MO220, EXCEPT FOR T2444-1, T2444-3 AND T2444-4.

|  |  |   |
|--|--|---|
|  |  |   |
| <small>PROPRIETARY INFORMATION</small>   |  |   |
| <small>TITLE PACKAGE OUTLINE</small><br><small>12, 16, 20, 24L THIN QFN, 4x4x0.8mm</small> |  |   |
| <small>APPROVAL</small>  | <small>DOCUMENT CONTROL NO.</small><br>21-0139 | <small>REV.</small><br>C <span style="float: right;">2/2</span> |

# Dual, Ultra-Low-Power, 10-Bit, Voltage-Output DACs

## Package Information (continued)

(The package drawing(s) in this data sheet may not reflect the most current specifications. For the latest package outline information, go to [www.maxim-ic.com/packages](http://www.maxim-ic.com/packages).)

MAX5522-MAX5525

8LUMAXDFPS

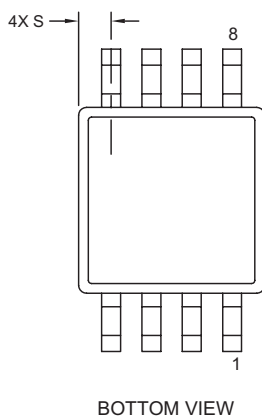
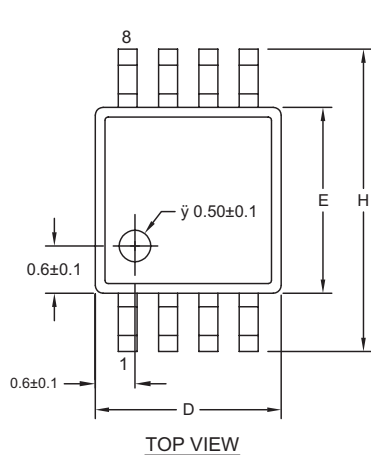

| DIM      | INCHES      |             | MILLIMETERS |             |
|----------|-------------|-------------|-------------|-------------|
|          | MIN         | MAX         | MIN         | MAX         |
| A        | -           | 0.043       | -           | 1.10        |
| A1       | 0.002       | 0.006       | 0.05        | 0.15        |
| A2       | 0.030       | 0.037       | 0.75        | 0.95        |
| b        | 0.010       | 0.014       | 0.25        | 0.36        |
| c        | 0.005       | 0.007       | 0.13        | 0.18        |
| D        | 0.116       | 0.120       | 2.95        | 3.05        |
| e        | 0.0256 BSC  |             | 0.65 BSC    |             |
| E        | 0.116       | 0.120       | 2.95        | 3.05        |
| H        | 0.188       | 0.198       | 4.78        | 5.03        |
| L        | 0.016       | 0.026       | 0.41        | 0.66        |
| $\alpha$ | 0 $^\infty$ | 6 $^\infty$ | 0 $^\infty$ | 6 $^\infty$ |
| S        | 0.0207 BSC  |             | 0.5250 BSC  |             |

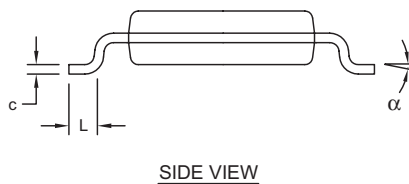
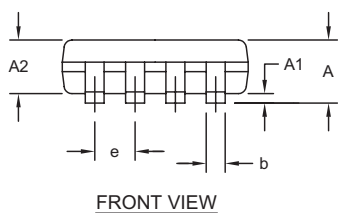

**NOTES:**

1. D&E DO NOT INCLUDE MOLD FLASH.
2. MOLD FLASH OR PROTRUSIONS NOT TO EXCEED 0.15MM (.006").
3. CONTROLLING DIMENSION: MILLIMETERS.
4. MEETS JEDEC MO-187C-AA.

|   |   |
|---|---|
|   |   |
| <small>PROPRIETARY INFORMATION</small>                        |   |
| <small>TITLE:</small><br><b>PACKAGE OUTLINE, 8L uMAX/uSOP</b> |   |
| <small>APPROVAL</small>                                       | <small>DOCUMENT CONTROL NO.</small><br><b>21-0036</b> |
| <small>REV.</small><br><b>J</b>                               | <small>REV.</small><br><b>1/1</b>                     |

Maxim cannot assume responsibility for use of any circuitry other than circuitry entirely embodied in a Maxim product. No circuit patent licenses are implied. Maxim reserves the right to change the circuitry and specifications without notice at any time.

Maxim Integrated Products, 120 San Gabriel Drive, Sunnyvale, CA 94086 408-737-7600 23