

## Block Diagram

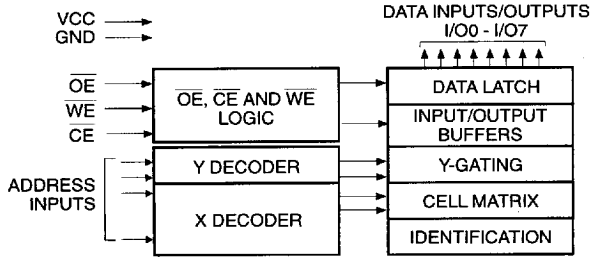

## Absolute Maximum Ratings\*

Temperature Under Bias.....	-55°C to +125°C
Storage Temperature.....	-65°C to +150°C
All Input Voltages (including N.C. Pins) with Respect to Ground .....	-0.6 V to +6.25 V
All Output Voltages with Respect to Ground .....	-0.6 V to V <sub>CC</sub> +0.6 V
Voltage on $\overline{OE}$ and A9 with Respect to Ground .....	-0.6 V to +13.5 V

\*NOTICE: Stresses beyond those listed under "Absolute Maximum Ratings" may cause permanent damage to the device. This is a stress rating only and functional operation of the device at these or any other conditions beyond those indicated in the operational sections of this specification is not implied. Exposure to absolute maximum rating conditions for extended periods may affect device reliability.

## Device Operation

**READ:** The AT28C16 is accessed like a Static RAM. When  $\overline{CE}$  and  $\overline{OE}$  are low and  $\overline{WE}$  is high, the data stored at the memory location determined by the address pins is asserted on the outputs. The outputs are put in a high impedance state whenever  $\overline{CE}$  or  $\overline{OE}$  is high. This dual line control gives designers increased flexibility in preventing bus contention.

**BYTE WRITE:** Writing data into the AT28C16 is similar to writing into a Static RAM. A low pulse on the  $\overline{WE}$  or  $\overline{CE}$  input with  $\overline{OE}$  high and  $\overline{CE}$  or  $\overline{WE}$  low (respectively) initiates a byte write. The address location is latched on the last falling edge of  $\overline{WE}$  (or  $\overline{CE}$ ); the new data is latched on the first rising edge. Internally, the device performs a self-clear before write. Once a byte write has been started, it will automatically time itself to completion. Once a programming operation has been initiated and for the duration of t<sub>wc</sub>, a read operation will effectively be a polling operation.

**FAST BYTE WRITE:** The AT28C16E offers a byte write time of 200 μs maximum. This feature allows the entire device to be rewritten in 0.4 seconds.

**DATA POLLING:** The AT28C16 provides  $\overline{DATA POLLING}$  to signal the completion of a write cycle. During a write

cycle, an attempted read of the data being written results in the complement of that data for I/O<sub>7</sub> (the other outputs are indeterminate). When the write cycle is finished, true data appears on all outputs.

**WRITE PROTECTION:** Inadvertent writes to the device are protected against in the following ways. (a) V<sub>cc</sub> sense— if V<sub>cc</sub> is below 3.8 V (typical) the write function is inhibited. (b) V<sub>cc</sub> power on delay— once V<sub>cc</sub> has reached 3.8 V the device will automatically time out 5 ms (typical) before allowing a byte write. (c) Write Inhibit— holding any one of  $\overline{OE}$  low,  $\overline{CE}$  high or  $\overline{WE}$  high inhibits byte write cycles.

**CHIP CLEAR:** The contents of the entire memory of the AT28C16 may be set to the high state by the CHIP CLEAR operation. By setting  $\overline{CE}$  low and  $\overline{OE}$  to 12 volts, the chip is cleared when a 10 msec low pulse is applied to  $\overline{WE}$ .

**DEVICE IDENTIFICATION:** An extra 32 bytes of E<sup>2</sup>PROM memory are available to the user for device identification. By raising A9 to 12 ± 0.5 V and using address locations 7E0H to 7FFH the additional bytes may be written to or read from in the same manner as the regular memory array.

D.C. and A.C. Operating Range

		AT28C16-15	AT28C16-20	AT28C16-25
Operating Temperature (Case)	Com.	0°C - 70°C	0°C - 70°C	0°C - 70°C
	Ind.	-40°C - 85°C	-40°C - 85°C	-40°C - 85°C
	Mil.	-55°C - 125°C	-55°C - 125°C	-55°C - 125°C
V <sub>CC</sub> Power Supply		5 V ± 10%	5 V ± 10%	5 V ± 10%

2

Operating Modes

Mode	$\overline{CE}$	$\overline{OE}$	$\overline{WE}$	I/O
Read	V <sub>IL</sub>	V <sub>IL</sub>	V <sub>IH</sub>	D <sub>OUT</sub>
Write <sup>(2)</sup>	V <sub>IL</sub>	V <sub>IH</sub>	V <sub>IL</sub>	D <sub>IN</sub>
Standby/Write Inhibit	V <sub>IH</sub>	X <sup>(1)</sup>	X	High Z
Write Inhibit	X	X	V <sub>IH</sub>	
Write Inhibit	X	V <sub>IL</sub>	X	
Output Disable	X	V <sub>IH</sub>	X	High Z
Chip Erase	V <sub>IL</sub>	V <sub>H</sub> <sup>(3)</sup>	V <sub>IL</sub>	High Z

Notes: 1. X can be V<sub>IL</sub> or V<sub>IH</sub>.

3. V<sub>H</sub> = 12.0 V ± 0.5 V.

2. Refer to A.C. Programming Waveforms.

D.C. Characteristics

Symbol	Parameter	Condition	Min	Max	Units
I <sub>LI</sub>	Input Load Current	V <sub>IN</sub> = 0 V to V <sub>CC</sub> + 1 V		10	μA
I <sub>LO</sub>	Output Leakage Current	V <sub>I/O</sub> = 0V to V <sub>CC</sub>		10	μA
I <sub>SB1</sub>	V <sub>CC</sub> Standby Current CMOS	$\overline{CE} = V_{CC} - 0.3 V$ to V <sub>CC</sub> + 1.0 V		100	μA
I <sub>SB2</sub>	V <sub>CC</sub> Standby Current TTL	$\overline{CE} = 2.0 V$ to V <sub>CC</sub> + 1.0 V	Com.	2	mA
			Ind., Mil.	3	mA
I <sub>CC</sub>	V <sub>CC</sub> Active Current A.C.	f = 5 MHz; I <sub>OUT</sub> = 0 mA CE = V <sub>IL</sub>	Com.	30	mA
			Ind., Mil.	45	mA
V <sub>IL</sub>	Input Low Voltage		0.8		V
V <sub>IH</sub>	Input High Voltage		2.0		V
V <sub>OL</sub>	Output Low Voltage	I <sub>OL</sub> = 2.1 mA		.4	V
V <sub>OH</sub>	Output High Voltage	I <sub>OH</sub> = -400 μA	2.4		V

Pin Capacitance (f = 1 MHz, T = 25°C)<sup>(1)</sup>

	Typ	Max	Units	Conditions
C <sub>IN</sub>	4	6	pF	V <sub>IN</sub> = 0 V
C <sub>OUT</sub>	8	12	pF	V <sub>OUT</sub> = 0 V

Note: 1. This parameter is characterized and is not 100% tested.



1074177 0007901 052

## A.C. Read Characteristics

Symbol	Parameter	AT28C16-15		AT28C16-20		AT28C16-25		Units
		Min	Max	Min	Max	Min	Max	
$t_{ACC}$	Address to Output Delay		150		200		250	ns
$t_{CE}^{(1)}$	$\overline{CE}$ to Output Delay		150		200		250	ns
$t_{OE}^{(2)}$	$\overline{OE}$ to Output Delay	10	70	10	80	10	100	ns
$t_{DF}^{(3,4)}$	$\overline{CE}$ or $\overline{OE}$ High to Output Float	0	50	0	55	0	60	ns
$t_{OH}$	Output Hold from $\overline{OE}$ , $\overline{CE}$ or Address, whichever occurred first	0		0		0		ns

## A.C. Read Waveforms<sup>(1,2,3,4)</sup>

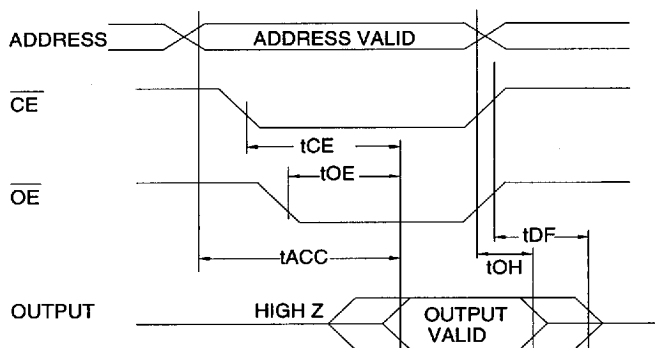

### Notes:

- $\overline{CE}$  may be delayed up to  $t_{ACC} - t_{CE}$  after the address transition without impact on  $t_{ACC}$ .
- $\overline{OE}$  may be delayed up to  $t_{CE} - t_{OE}$  after the falling edge of  $\overline{CE}$  without impact on  $t_{CE}$  or by  $t_{ACC} - t_{OE}$  after an address change without impact on  $t_{ACC}$ .
- $t_{DF}$  is specified from  $\overline{OE}$  or  $\overline{CE}$  whichever occurs first ( $C_L = 5 \text{ pF}$ ).
- This parameter is characterized and is not 100% tested.

## Input Test Waveforms and Measurement Level

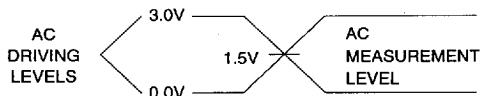

$t_R, t_F < 20 \text{ ns}$

## Output Test Load

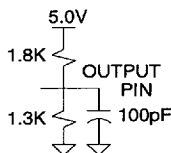

**A.C. Write Characteristics**

Symbol	Parameter	Min	Typ	Max	Units
tAS, tOES	Address, OE Set-up Time	10			ns
tAH	Address Hold Time	50			ns
tWP	Write Pulse Width ( $\overline{WE}$ or $\overline{CE}$ )	100		1000	ns
tDS	Data Set-up Time	50			ns
tDH, tOEH	Data, OE Hold Time	10			ns
tCS, tCH	$\overline{CE}$ to $\overline{WE}$ and $\overline{WE}$ to $\overline{CE}$ Set-up and Hold Time	0			ns
twc	Write Cycle Time	AT28C16	0.5	1.0	ms
		AT28C16E	100	200	$\mu$ s

**A.C. Write Waveforms-  $\overline{WE}$  Controlled**

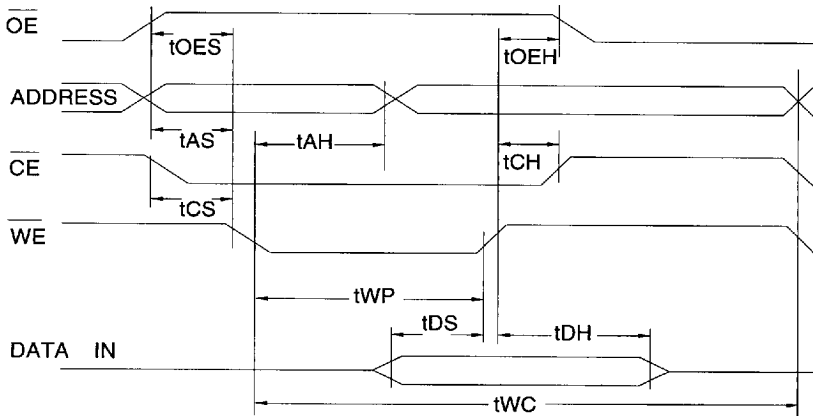

**A.C. Write Waveforms-  $\overline{CE}$  Controlled**

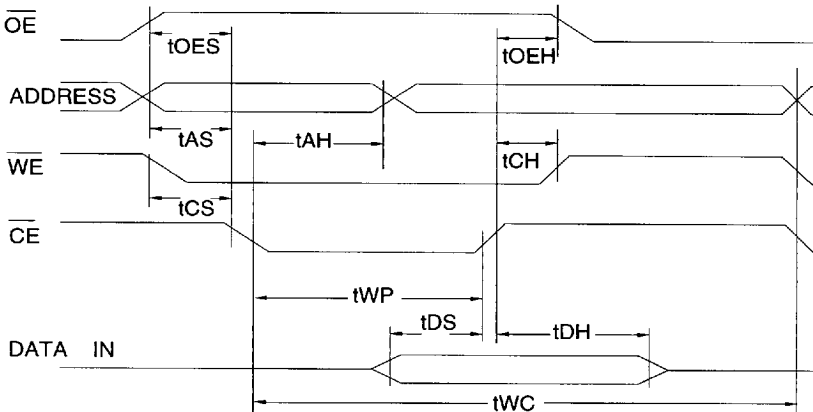

1074177 0007903 925

## Data Polling Characteristics<sup>(1)</sup>

Symbol	Parameter	Min	Typ	Max	Units
t <sub>DH</sub>	Data Hold Time	10			ns
t <sub>OEH</sub>	$\overline{OE}$ Hold Time	10			ns
t <sub>OE</sub>	$\overline{OE}$ to Output Delay <sup>(2)</sup>				ns
t <sub>WR</sub>	Write Recovery Time	0			ns

Notes: 1. These parameters are characterized and not 100% tested.  
2. See A.C. Characteristics.

## Data Polling Waveforms

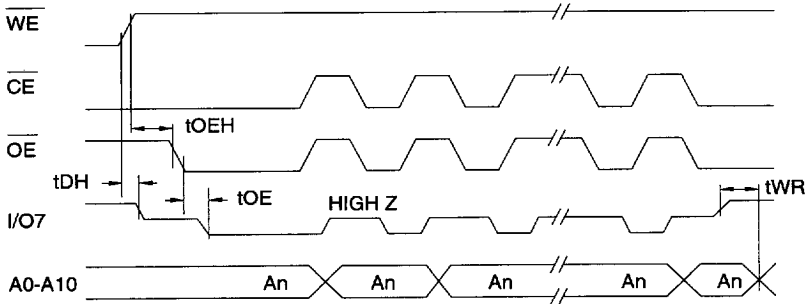

## Chip Erase Waveforms

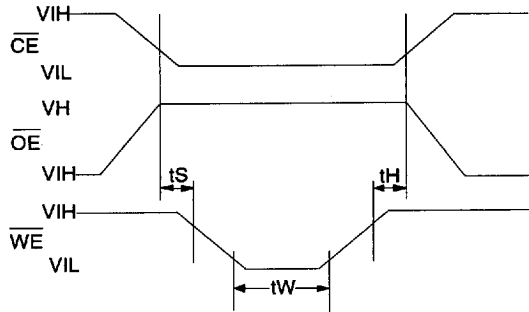

t<sub>S</sub> = t<sub>H</sub> = 1  $\mu$ sec (min.)  
t<sub>W</sub> = 10 msec (min.)  
V<sub>H</sub> = 12.0 V  $\pm$  0.5 V

NORMALIZED SUPPLY CURRENT vs. TEMPERATURE

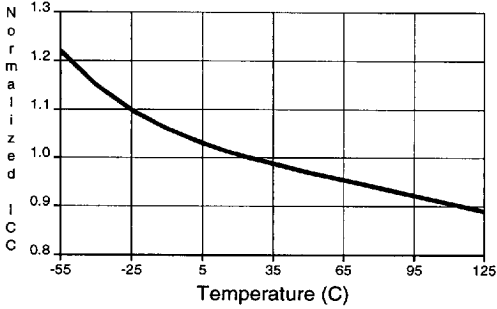

NORMALIZED SUPPLY CURRENT vs. SUPPLY VOLTAGE

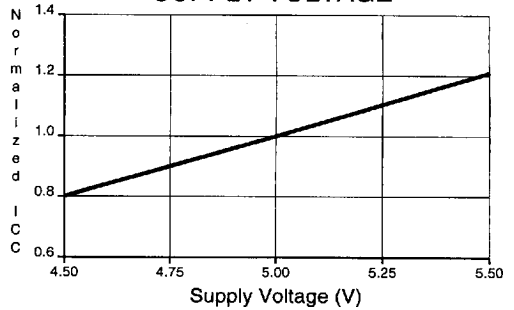

NORMALIZED SUPPLY CURRENT vs. ADDRESS FREQUENCY

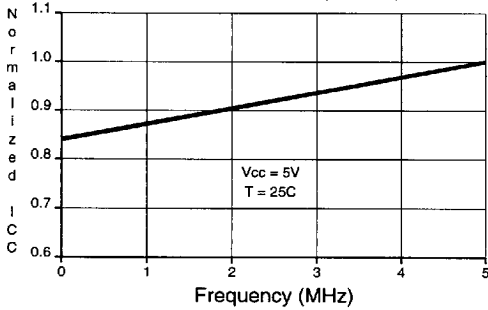

NORMALIZED ACCESS TIME vs. OUTPUT LOAD

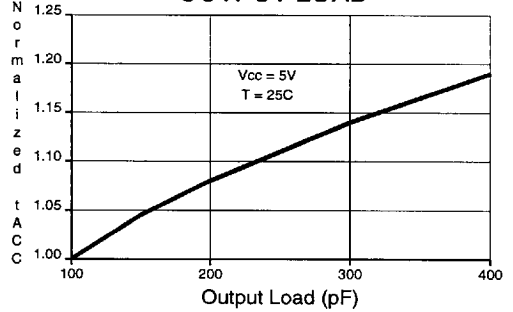

OUTPUT SINK CURRENT vs. OUTPUT VOLTAGE

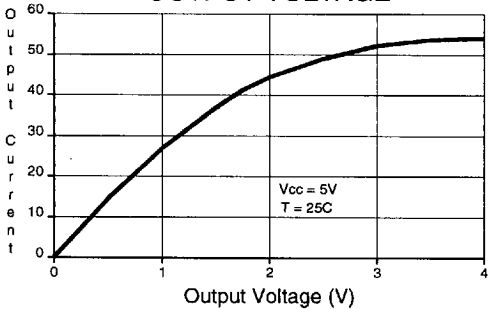

OUTPUT SOURCE CURRENT vs. OUTPUT VOLTAGE

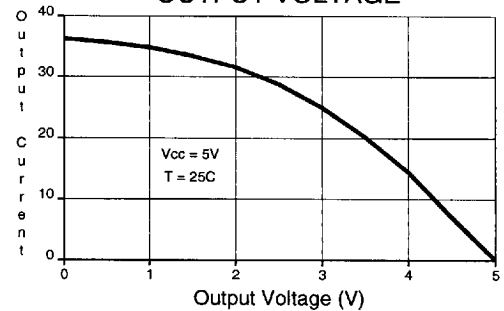



## Ordering Information<sup>(1)</sup>

tACC (ns)	Icc (mA)		Ordering Code	Package	Operation Range
	Active	Standby			
150	30	0.1	AT28C16(E)-15DC AT28C16(E)-15JC AT28C16(E)-15PC AT28C16(E)-15SC	24D6 32J 24P6 24S	Commercial (0°C to 70°C)
150	45	0.1	AT28C16(E)-15JI AT28C16(E)-15PI AT28C16(E)-15SI	32J 24P6 24S	Industrial (-40°C to 85°C)
			AT28C16(E)-15DM/883	24D6	Military/883C Class B, Fully Compliant (-55°C to 125°C)
200	30	0.1	AT28C16(E)-20DC AT28C16(E)-20JC AT28C16(E)-20PC AT28C16(E)-20SC	24D6 32J 24P6 24S	Commercial (0°C to 70°C)
200	45	0.1	AT28C16(E)-20JI AT28C16(E)-20PI AT28C16(E)-20SI	32J 24P6 24S	Industrial (-40°C to 85°C)
			AT28C16(E)-20DM/883	24D6	Military/883C Class B, Fully Compliant (-55°C to 125°C)
250	30	0.1	AT28C16(E)-25DC AT28C16(E)-25JC AT28C16(E)-25PC AT28C16(E)-25SC AT28C16-W	24D6 32J 24P6 24S DIE	Commercial (0°C to 70°C)
250	45	0.1	AT28C16(E)-25JI AT28C16(E)-25PI AT28C16(E)-25SI	32J 24P6 24S	Industrial (-40°C to 85°C)
			AT28C16(E)-25DM/883	24D6	Military/883C Class B, Fully Compliant (-55°C to 125°C)

Note: 1. See valid Part Number table below.

## Valid Part Numbers

The following table lists standard Atmel products that can be ordered.

Device Numbers	Speed	Package and Temperature Combinations
AT28C16	15	DC, JC, JI, PC, PI, SC, SI, DM/883
AT28C16E	15	DC, JC, JI, PC, PI, SC, SI, DM/883
AT28C16	20	DC, JC, JI, PC, PI, SC, SI, DM/883
AT28C16E	20	DC, JC, JI, PC, PI, SC, SI, DM/883
AT28C16	25	DC, JC, JI, PC, PI, SC, SI, DM/883
AT28C16E	25	DC, JC, JI, PC, PI, SC, SI, DM/883

2-112

**AT28C16**

1074177 0007906 634

This Material Copyrighted By Its Respective Manufacturer

Ordering Information

2

Package Type	
<b>24D6</b>	24 Lead, 0.600" Wide, Non-Windowed, Ceramic Dual Inline Package (Cerdip)
<b>32J</b>	32 Lead, Plastic J-Leaded Chip Carrier (PLCC)
<b>24P6</b>	24 Lead, 0.600" Wide, Plastic Dual Inline Package (PDIP)
<b>24S</b>	24 Lead, 0.300" Wide, Plastic Gull Wing Small Outline (SOIC)
<b>W</b>	Die
Options	
<b>Blank</b>	Standard Device: Endurance = 10K Write Cycles; Write Time = 1 ms
<b>E</b>	High Endurance Option: Endurance = 100K Write Cycles; Write Time = 200 $\mu$ s



1074177 0007907 570