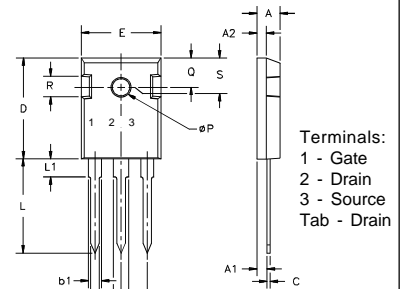

| Symbol | Test Conditions | Characteristic Values ($T_j = 25^\circ\text{C}$, unless otherwise specified) | | |
|--------------|--|---|------|------|
| | | min. | typ. | max. |
| g_{fs} | $V_{DS} = 15\text{ V}; I_D = 0.5 \cdot I_{D25}$, pulse test | 4 | 10 | S |
| C_{iss} | $V_{GS} = 0\text{ V}, V_{DS} = 25\text{ V}, f = 1\text{ MHz}$ | | 2900 | pF |
| C_{oss} | | | 315 | pF |
| C_{rss} | | | 50 | pF |
| $t_{d(on)}$ | $V_{GS} = 10\text{ V}, V_{DS} = 0.5 \cdot V_{DSS}, I_D = 0.5 \cdot I_{D25}$ $R_G = 2\ \Omega$ (External), | | 20 | ns |
| t_r | | | 23 | ns |
| $t_{d(off)}$ | | | 40 | ns |
| t_f | | | 15 | ns |
| $Q_{g(on)}$ | $V_{GS} = 10\text{ V}, V_{DS} = 0.5 \cdot V_{DSS}, I_D = 0.5 \cdot I_{D25}$ | | 90 | nC |
| Q_{gs} | | | 30 | nC |
| Q_{gd} | | | 40 | nC |
| R_{thJC} | | | 0.42 | K/W |
| R_{thCK} | (TO-247) | | 0.25 | K/W |

| Source-Drain Diode | | Characteristic Values ($T_j = 25^\circ\text{C}$, unless otherwise specified) | | |
|--------------------|---|---|------|---------------|
| Symbol | Test Conditions | min. | typ. | max. |
| I_S | $V_{GS} = 0\text{ V}$ | | | 12 A |
| I_{SM} | Repetitive; pulse width limited by T_{JM} | | | 48 A |
| V_{SD} | $I_F = I_S, V_{GS} = 0\text{ V}$, Pulse test, $t \leq 300\ \mu\text{s}$, duty cycle $d \leq 2\%$ | | | 1.5 V |
| t_{rr} | $I_F = I_S, -di/dt = 100\text{ A}/\mu\text{s}, V_R = 100\text{ V}$ | | 200 | ns |
| Q_{RM} | | | 0.6 | μC |
| I_{RM} | | | 7 | A |

TO-247 AD (IXFH) Outline

Terminals:
 1 - Gate
 2 - Drain
 3 - Source
 Tab - Drain

| Dim. | Millimeter | | Inches | |
|----------------|------------|-------|--------|-------|
| | Min. | Max. | Min. | Max. |
| A | 4.7 | 5.3 | .185 | .209 |
| A ₁ | 2.2 | 2.54 | .087 | .102 |
| A ₂ | 2.2 | 2.6 | .087 | .102 |
| b | 1.0 | 1.4 | .040 | .055 |
| b ₁ | 1.65 | 2.13 | .065 | .084 |
| b ₂ | 2.87 | 3.12 | .113 | .123 |
| C | .4 | .8 | .016 | .031 |
| D | 20.80 | 21.46 | .819 | .845 |
| E | 15.75 | 16.26 | .610 | .640 |
| e | 5.20 | 5.72 | 0.205 | 0.225 |
| L | 19.81 | 20.32 | .780 | .800 |
| L1 | | 4.50 | | .177 |
| ØP | 3.55 | 3.65 | .140 | .144 |
| Q | 5.89 | 6.40 | 0.232 | 0.252 |
| R | 4.32 | 5.49 | .170 | .216 |
| S | 6.15 | BSC | .242 | BSC |

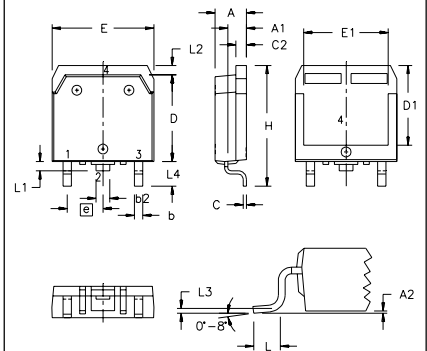
TO-268 Outline

| SYM | INCHES | | MILLIMETERS | |
|-----|--------|------|-------------|-------|
| | MIN | MAX | MIN | MAX |
| A | .193 | .201 | 4.90 | 5.10 |
| A1 | .106 | .114 | 2.70 | 2.90 |
| A2 | .001 | .010 | 0.02 | 0.25 |
| b | .045 | .057 | 1.15 | 1.45 |
| b2 | .075 | .083 | 1.90 | 2.10 |
| C | .016 | .026 | 0.40 | 0.65 |
| C2 | .057 | .063 | 1.45 | 1.60 |
| D | 54.3 | 55.1 | 13.80 | 14.00 |
| D1 | 48.8 | 50.0 | 12.40 | 12.70 |
| E | 62.4 | 63.2 | 15.85 | 16.05 |
| E1 | 52.4 | 53.5 | 13.30 | 13.60 |
| e | .215 | BSC | 5.45 | BSC |
| H | .736 | .752 | 18.70 | 19.10 |
| L | .094 | .106 | 2.40 | 2.70 |
| L1 | .047 | .055 | 1.20 | 1.40 |
| L2 | .039 | .045 | 1.00 | 1.15 |
| L3 | .010 | BSC | 0.25 | BSC |
| L4 | .150 | .161 | 3.80 | 4.10 |

IXYS reserves the right to change limits, test conditions, and dimensions.

| | | | | | | | |
|--|-----------|-----------|-----------|-----------|-----------|-----------|-------------|
| IXYS MOSFETs and IGBTs are covered by one or more of the following U.S. patents: | 4,835,592 | 4,881,106 | 5,017,508 | 5,049,961 | 5,187,117 | 5,486,715 | 6,306,728B1 |
| | 4,850,072 | 4,931,844 | 5,034,796 | 5,063,307 | 5,237,481 | 5,381,025 | |

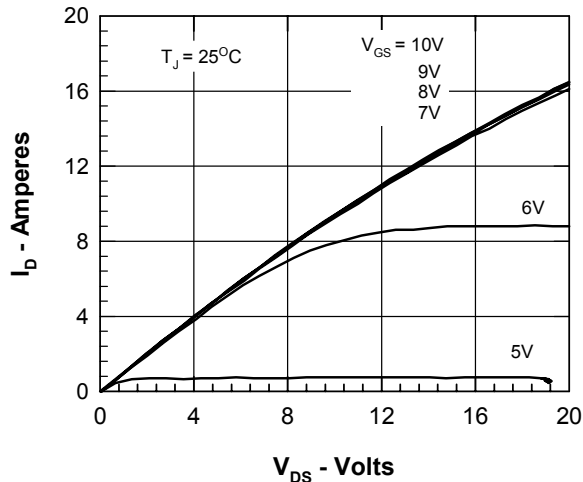

Figure 1. Output Characteristics at 25°C

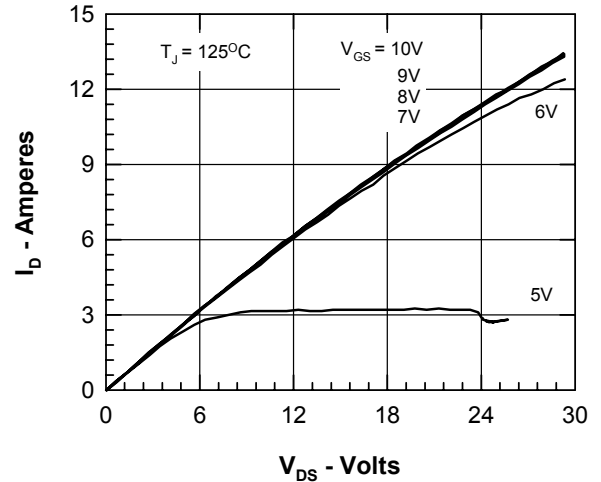

Figure 2. Output Characteristics at 125°C

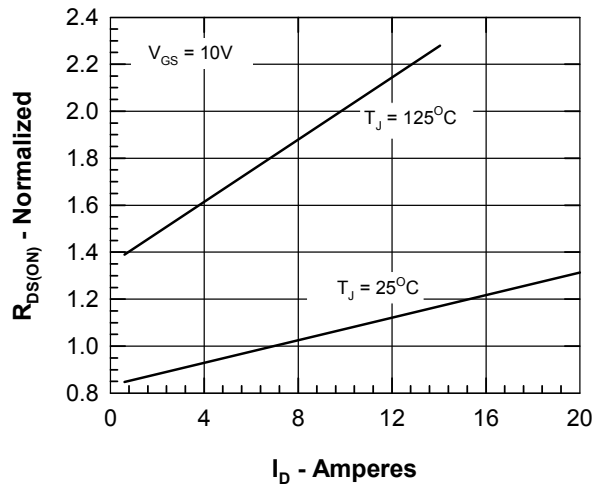

Figure 3. $R_{DS(on)}$ normalized to value at $I_D = 12A$

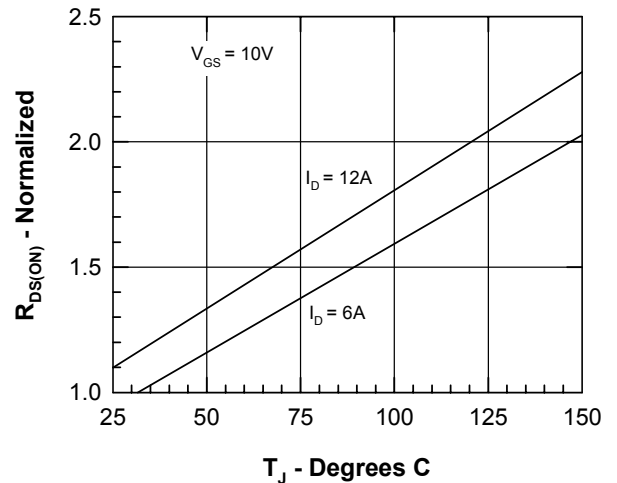

Figure 4. $R_{DS(on)}$ normalized to value at $I_D = 12A$

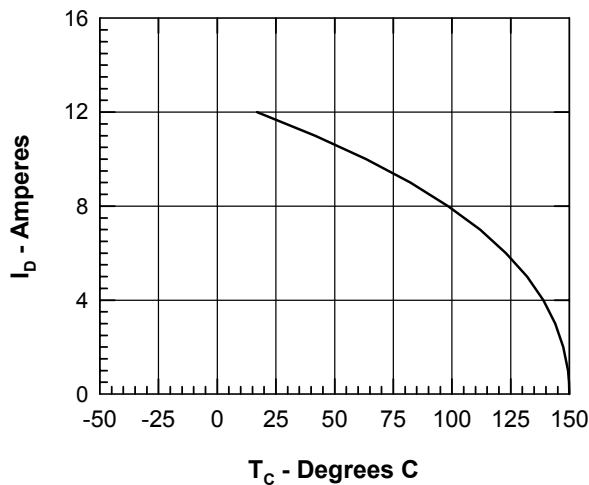

Figure 5. Drain Current vs. Case Temperature

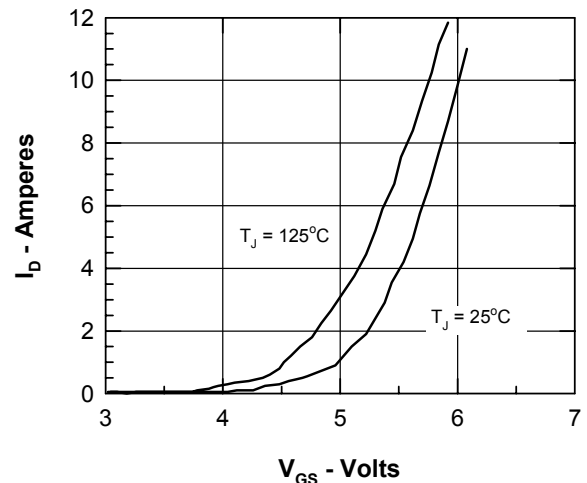

Figure 6. Admittance Curves

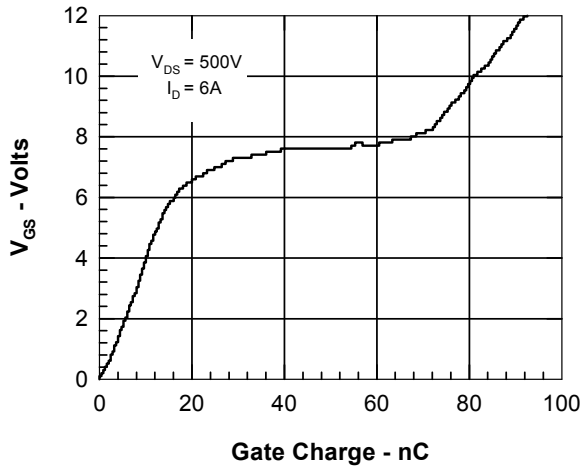

Figure 7. Gate Charge

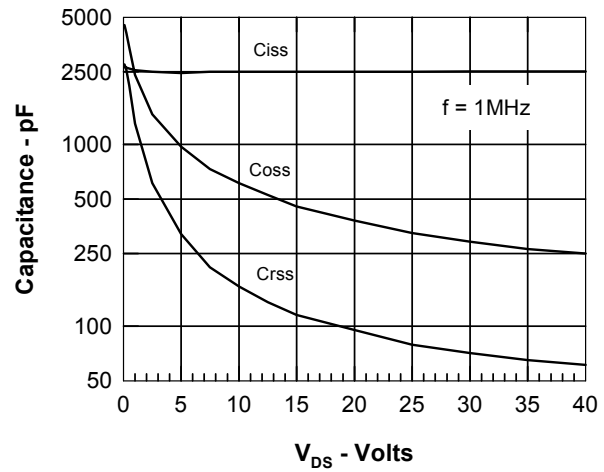

Figure 8. Capacitance Curves

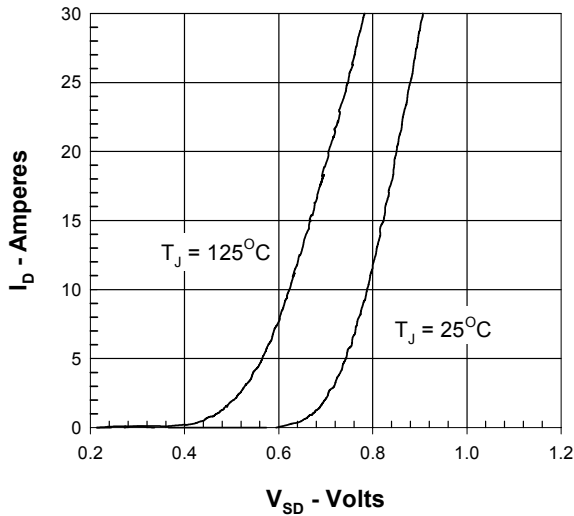

Figure 9. Source Current vs. Source to Drain Voltage

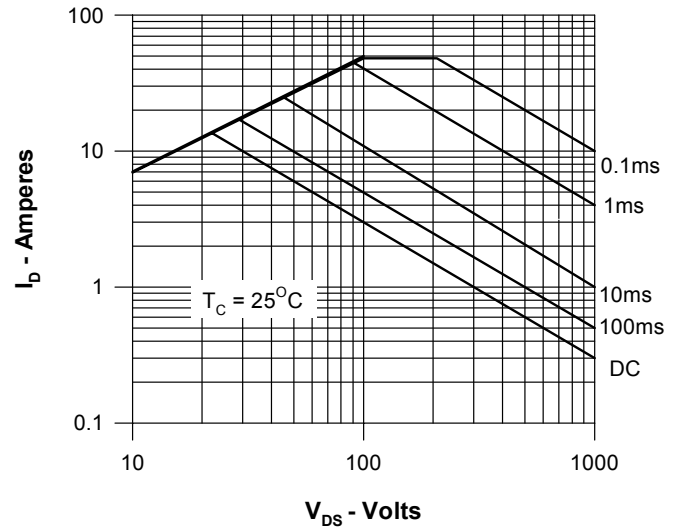

Figure 10. Forward Bias Safe Operating Area

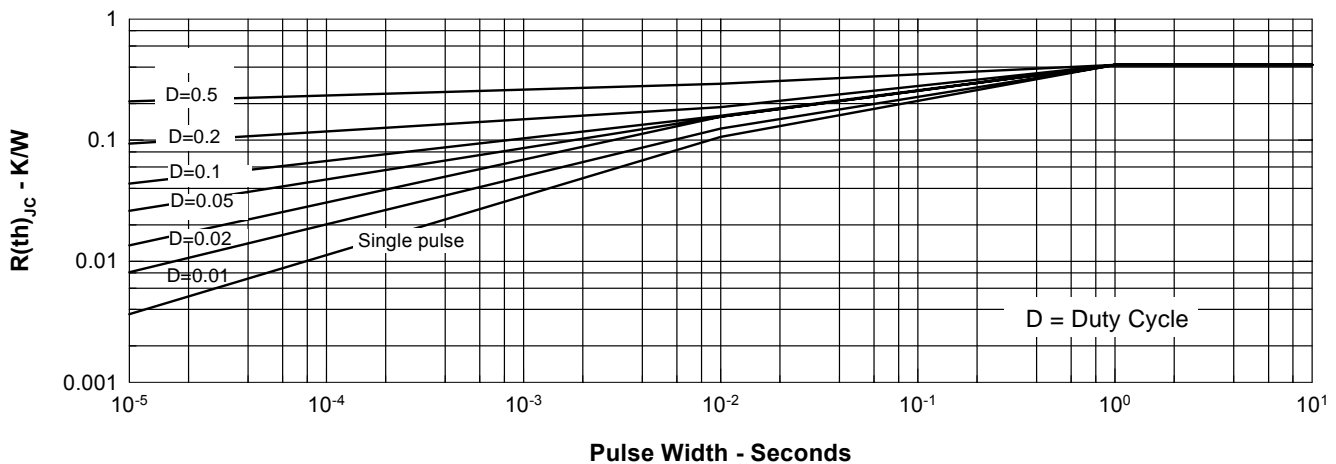

Figure 11. Transient Thermal Resistance

IXYS reserves the right to change limits, test conditions, and dimensions.

IXYS MOSFETs and IGBTs are covered by one or more of the following U.S. patents:

| | | | | | | |
|-----------|-----------|-----------|-----------|-----------|-----------|-------------|
| 4,835,592 | 4,881,106 | 5,017,508 | 5,049,961 | 5,187,117 | 5,486,715 | 6,306,728B1 |
| 4,850,072 | 4,931,844 | 5,034,796 | 5,063,307 | 5,237,481 | 5,381,025 | |



Disclaimer Notice - Information furnished is believed to be accurate and reliable. However, users should independently evaluate the suitability of and test each product selected for their own applications. Littelfuse products are not designed for, and may not be used in, all applications. Read complete Disclaimer Notice at www.littelfuse.com/disclaimer-electronics.