

## Functional Block Diagram

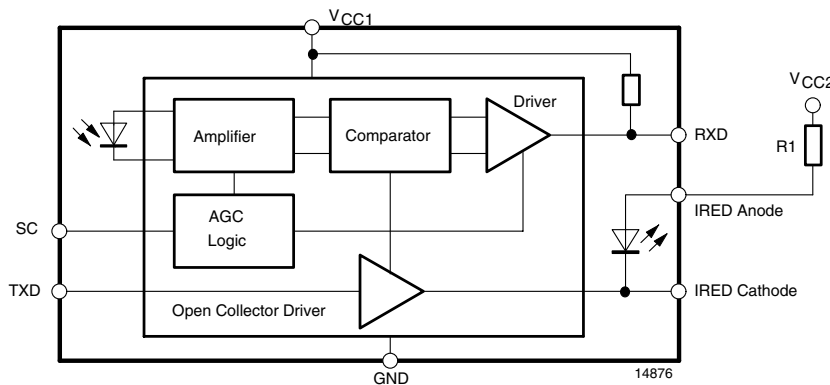

## Pin Description

Pin Number	Function	Description	I/O	Active
1	IRED Anode	IRED anode, should be externally connected to VCC2 through a current control resistor		
2	IRED Cathode	IRED cathode, internally connected to driver transistor		
3	TXD	Transmit Data Input	I	HIGH
4	RXD	Received Data Output, open collector. No external pull-up or pull-down resistor is required (20 kΩ resistor internal to device). Output data is invalid during transmission.	O	LOW
5	NC	No internal connection		
6	V <sub>CC1</sub>	Supply Voltage		
7	SC	Sensitivity control	I	HIGH
8	GND	Ground		

## Pinout

TFDU4100  
weight 200 mg

### "U" Option BabyFace (Universal)

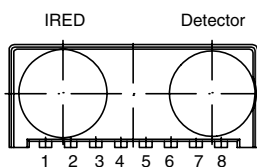

17087

## Definitions:

In the Vishay transceiver data sheets the following nomenclature is used for defining the IrDA operating modes:

SIR: 2.4 kbit/s to 115.2 kbit/s, equivalent to the basic serial infrared standard with the physical layer version IrPhy 1.0

MIR: 576 kbit/s to 1152 kbit/s

FIR: 4 Mbit/s

VFIR: 16 Mbit/s

MIR and FIR were implemented with IrPhy 1.1, followed by IrPhy 1.2, adding the SIR Low Power Standard. IrPhy 1.3 extended the Low Power Option to MIR and FIR and VFIR was added with IrPhy 1.4.A new version of the standard in any case obsoletes the former version.

## Absolute Maximum Ratings

Reference point Ground (pin 8) unless otherwise noted.

Typical values are for DESIGN AID ONLY, not guaranteed nor subject to production testing.

Parameter	Test Conditions	Symbol	Min	Typ.	Max	Unit
Supply voltage range	$0\text{ V} \leq V_{CC2} \leq 6\text{ V}$	$V_{CC1}$	- 0.5		+ 6	V
	$0\text{ V} \leq V_{CC1} \leq 6\text{ V}$	$V_{CC2}$	- 0.5		+ 6	V
Input current	for all pins, except IRED anode pin				10	mA
Output sink current					25	mA
Power dissipation	see derating curve	$P_D$			200	mW
Junction temperature		$T_J$			125	°C
Ambient temperature range (operating)		$T_{amb}$	- 25		+ 85	°C
Storage temperature range		$T_{stg}$	- 25		+ 85	°C
Soldering temperature	see recommended solder profile				260	°C
Average IRED current		$I_{IRED(DC)}$			100	mA
Repetitive pulsed IRED current	$t < 90\ \mu\text{s}$ , $\text{ton} < 20\%$	$I_{IRED(RP)}$			500	mA
IRED anode voltage		$V_{IRED A}$	- 0.5		+ 6	V
Transmitter data input voltage		$V_{TXD}$	- 0.5		$V_{CC1} + 0.5$	V
Receiver data output voltage		$V_{RXD}$	- 0.5		$V_{CC1} + 0.5$	V

## Eye safety information

Parameter	Test Conditions	Symbol	Min	Typ.	Max	Unit
Virtual source size	Method: (1-1/e) encircled energy	d	2.5	2.8		mm
Maximum intensity for class 1	IEC60825-1 or EN60825-1, edition Jan. 2001	$I_e$			(500) <sup>*) **)</sup>	mW/sr

\*) The device is a "class 1" device.

\*\*) IrDA specifies the max. intensity with 500 mW/sr.

## Electrical Characteristics

### Transceiver

$T_{amb} = 25\text{ °C}$ ,  $V_{CC} = 2.7\text{ V}$  to  $5.5\text{ V}$  unless otherwise noted.

Typical values are for DESIGN AID ONLY, not guaranteed nor subject to production testing.

Parameter	Test Conditions	Symbol	Min	Typ.	Max	Unit
Supported data rates	base band		2.4		115.2	kbit/s
Supply voltage	receive mode	$V_{CC1}$	2.7		5.5	V
	transmit mode, $R2 = 47\ \Omega$ (see recommended application circuit)	$V_{CC2}$	2.0		5.5	V
Supply current pin $V_{CC1}$ (receive mode)	$V_{CC1} = 5.5\text{ V}$	$I_{CC1(Rx)}$		1.3	2.5	mA
	$V_{CC1} = 2.7\text{ V}$	$I_{CC1(Rx)}$		1.0	1.5	mA
Supply current pin $V_{CC1}$ (avg) (transmit mode), 20 % duty cycle	$I_{IRED} = 210\text{ mA}$ (at IRED anode pin), $V_{CC1} = 5.5\text{ V}$	$I_{CC1(Tx)}$		5.0	5.5	mA
	$I_{IRED} = 210\text{ mA}$ (at IRED anode pin), $V_{CC1} = 2.7\text{ V}$	$I_{CC1(Tx)}$		3.5	4.5	mA
Leakage current of IR emitter, IRED anode pin	$V_{CC1} = \text{OFF}$ , $\text{TXD} = \text{LOW}$ , $V_{CC2} = 6\text{ V}$ , $T = -25\text{ to }+85\text{ °C}$	$I_{L(IRED A)}$		0.005	0.5	$\mu\text{A}$
Transceiver power on settling time		$T_{PON}$			50	$\mu\text{s}$

## Optoelectronic Characteristics

### Receiver

$T_{amb} = 25\text{ }^{\circ}\text{C}$ ,  $V_{CC} = 2.7\text{ V}$  to  $5.5\text{ V}$  unless otherwise noted. Typical values are for DESIGN AID ONLY, not guaranteed nor subject to production testing.

Parameter	Test Conditions	Symbol	Min	Typ.	Max	Unit
Minimum detection threshold irradiance	BER < $10^{-8}$ (IrDA specification)					
	$\alpha = \pm 15^{\circ}$ , SC = LOW, SIR	$E_e$		20	35	mW/m <sup>2</sup>
	$\alpha = \pm 15^{\circ}$ , SC = HIGH, SIR	$E_e$	6	10	15	mW/m <sup>2</sup>
Maximum detection threshold irradiance	$\alpha = \pm 90^{\circ}$ , $V_{CC1} = 5.0\text{ V}$	$E_e$	3.3	5		kW/m <sup>2</sup>
	$\alpha = \pm 90^{\circ}$ , $V_{CC1} = 3.0\text{ V}$	$E_e$	8	15		kW/m <sup>2</sup>
Logic LOW receiver input irradiance	Note: No detection below this input irradiance	$E_e$	4			mW/m <sup>2</sup>
Output voltage - RXD	Active, C = 15 pF, R = 2.2 k $\Omega$	$V_{OL}$		0.5	0.8	V
	non-active, C = 15 pF, R = 2.2 k $\Omega$	$V_{OH}$	$V_{CC1} - 0.5$			V
Output current - RXD	$V_{OL} < 0.8\text{ V}$	$I_{OL}$		4		mA
Rise time - RXD	active to inactive C = 15 pF, R = 2.2 k $\Omega$ to $V_{CC1}$	$t_{r(RXD)}$	20		200	ns
	active to inactive C = 15 pF, internal load only	$t_{r(RXD)}$	20		1400	ns
Fall time - RXD	inactive to active C = 15 pF, R = 2.2 k $\Omega$ to $V_{CC1}$	$t_{f(RXD)}$	20		200	ns
	inactive to active C = 15 pF, internal load only	$t_{f(RXD)}$	20		200	ns
Pulse width - RXD output		$t_{PW}$	1.63	4	4.3	$\mu\text{s}$
Jitter, leading edge of output signal	over a period of 10 bit, 115.2 kbit/s	$t_j$			2	$\mu\text{s}$
Latency		$t_L$		100	500	$\mu\text{s}$

### Transmitter

$T_{amb} = 25\text{ }^{\circ}\text{C}$ ,  $V_{CC} = 2.7\text{ V}$  to  $5.5\text{ V}$  unless otherwise noted. Typical values are for DESIGN AID ONLY, not guaranteed nor subject to production testing.

Parameter	Test Conditions	Symbol	Min	Typ.	Max	Unit
IREC operating current	IREC operating current can be adjusted by variation of R1. Current limiting resistor is in series to IREC: R1 = 14 $\Omega$ , $V_{CC2} = 5.0\text{ V}$	$I_d$		0.2	0.28	A
Logic LOW transmitter input voltage		$V_{IL(TXD)}$	0		0.8	V
Logic HIGH transmitter input voltage		$V_{IH(TXD)}$	2.4		$V_{CC1} + 0.5$	V
Output radiant intensity	In agreement with IEC825 eye safety limit, if current limiting resistor is in series to IREC: R1 = 14 $\Omega$ , $V_{CC2} = 5.0\text{ V}$ , $\alpha = \pm 15^{\circ}$	$I_e$	45	140	200	mW/sr
	TXD logic LOW level	$I_e$			0.04	mW/sr
Angle of half intensity		$\alpha$		$\pm 24$		$^{\circ}$
Peak wavelength of emission		$\lambda_p$	880		900	nm

Parameter	Test Conditions	Symbol	Min	Typ.	Max	Unit
Half-width of emission spectrum				45		nm
Optical rise time, fall time		$t_{rop}$ , $t_{fop}$		200	600	ns
Optical overshoot					25	%
Rising edge peak-to-peak jitter of optical output pulse	Over a period of 10 bits, independent of information content	$t_j$			0.2	$\mu$ s

### Recommended Circuit Diagram

The only required components for designing an IrDA® compatible application using Vishay Semiconductors SIR transceivers are a current limiting resistor to the IRED. However, depending on the entire system design and board layout, additional components may be required (see figure 1). It is recommended that the capacitors C1 and C2 are positioned as near as possible to the transceiver power supply pins. A tantalum capacitor should be used for C1, while a ceramic capacitor should be used for C2 to suppress RF noise. Also, when connecting the described circuit to the power supply, low impedance wiring should be used.

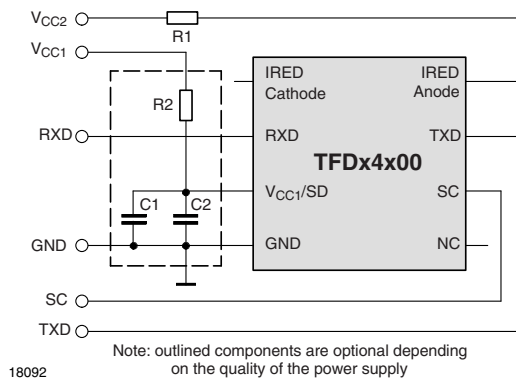

Figure 1. Recommended Application Circuit

R1 is used for controlling the current through the IR emitter. For increasing the output power of the IRED, the value of the resistor should be reduced. Similarly, to reduce the output power of the IRED, the value of the resistor should be increased. For typical values of R1 (see figures 2 and 3), e.g. for IrDA compliant operation ( $V_{CC2} = 5\text{ V} \pm 5\%$ ), a current control resistor of  $14\ \Omega$  is recommended. The upper drive current limitation is dependent on the duty cycle and is given by the absolute maximum ratings on the data sheet and the eye safety limitations given by IEC825.1. R2, C1 and C2 are optional and dependent on the quality of the supply voltage  $V_{CC1}$  and injected noise. An unstable

power supply with dropping voltage during transmission may reduce sensitivity (and transmission range) of the transceiver.

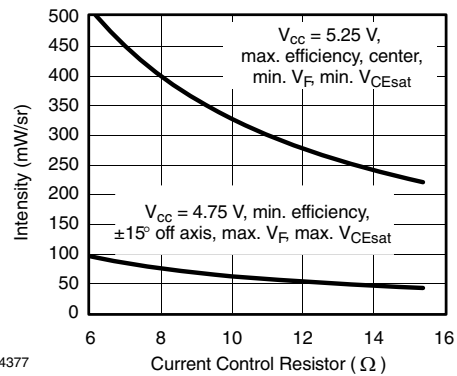

Figure 2.  $I_e$  vs. R1

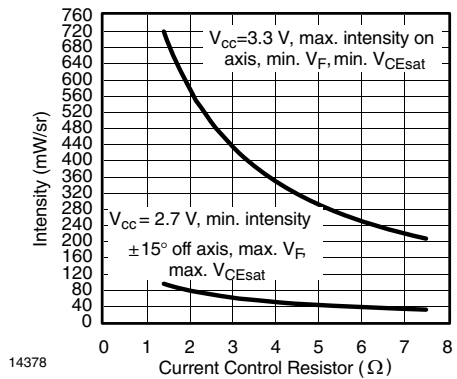

Figure 3.  $I_e$  vs. R1

**Table 1.**  
**Recommended Application Circuit Components**

Component	Recommended Value	Vishay Part Number
C1	4.7 $\mu$ F, Tantalum	293D 475X9 016B 2T
C2	0.1 $\mu$ F, Ceramic	VJ 1206 Y 104 J XXMT
R1	14 $\Omega$ , 0.25 W (recommended using two 7 $\Omega$ M, 0.125 W resistor in series, ( $V_{CC2} = 5$ V))	CRCW-1206-7R00-F-RT1
R2	47 $\Omega$ , 0.125 W	CRCW-1206-47R0-F-RT1

The sensitivity control (SC) pin allows the minimum detection irradiance threshold of the transceiver to be lowered when set to a logic HIGH. Lowering the irradiance threshold increases the sensitivity to infrared signals and increases transmission range up to 3 meters. However, setting the Pin SC to logic HIGH also makes the transceiver more susceptible to transmission errors due to an increased sensitivity to fluorescent light disturbances. It is recommended to set the Pin SC to logic LOW or left open if the increased range is not required or if the system will be operating in bright ambient light.

**Shutdown**

The internal switch for the IRED in Vishay Semiconductors SIR transceivers is designed to be operated like an open collector driver. Thus, the  $V_{CC2}$  source can be an unregulated power supply while only a well regulated power source with a supply current of 1.3 mA connected to  $V_{CC1/SD}$  is needed to provide power to the remainder of the transceiver circuitry in receive mode. The term  $V_{CC1/SD}$  is used here for the power supply pin to indicate that  $V_{CC1}$  can be switched off independently to shut down the transceiver. It is allowed to keep the power supply connected to the IRED Anode. In transmit mode, the current at  $V_{CC1}$  is slightly higher (approximately 4 mA average at 3 V supply current) and the voltage is not required to be kept as stable as in receive mode. A voltage drop of  $V_{CC1}$  is acceptable down to about 2.0 V when buffering the voltage directly from the Pin  $V_{CC1}$  to GND see figure 1). This configuration minimizes the influence of high current surges from the IRED on the internal analog control circuitry of the transceiver and the application circuit. Also board space and cost savings can be achieved by eliminating the additional linear regulator normally needed for the IRED’s high current requirements. The transceiver can be very efficiently shutdown by keeping the IRED connected to the power supply  $V_{CC2}$  but switching off  $V_{CC1/SD}$ . The power source to  $V_{CC1/SD}$  can be provided directly from a microcontroller (see figure 4). In shutdown, current loss is realized only as leakage current through the current limiting resistor to the IRED (typi-

cally 5 nA). The settling time after switching  $V_{CC1/SD}$  on again is approximately 50  $\mu$ s. Vishay Semiconductors’ TOIM4232 interface circuit is designed for this shutdown feature. The  $V_{CC\_SD}$ , S0 or S1 outputs on the TOIM4232 can be used to power the transceiver with the necessary supply current. If the microcontroller or the microprocessor is unable to drive the supply current required by the transceiver, a low-cost SOT23 pnp transistor can be used to switch voltage on and off from the regulated power supply (see figure 5). The additional component cost is minimal and saves the system designer additional power supply costs.

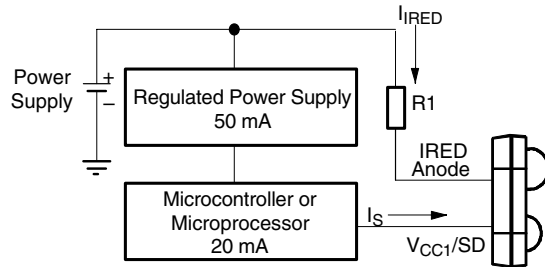

TFDU4100 (Note: Typical Values Listed)  
Receive Mode  
at 5 V:  $I_{RED} = 210$  mA,  $I_S = 1.3$  mA  
at 2.7 V:  $I_{RED} = 210$  mA,  $I_S = 1.0$  mA  
Transmit Mode  
at 5 V:  $I_{RED} = 210$  mA,  $I_S = 5$  mA (Avg.)  
at 2.7 V:  $I_{RED} = 210$  mA,  $I_S = 3.5$  mA (Avg.) 14878

Figure 4.

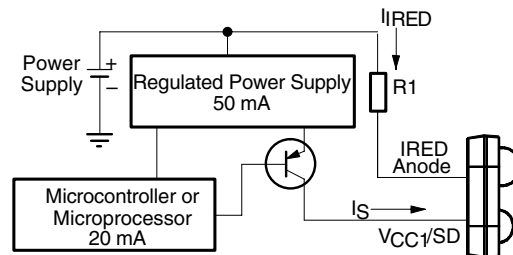

TFDU4100 (Note: Typical Values Listed)  
Receive Mode  
at 5 V:  $I_{RED} = 210$  mA,  $I_S = 1.3$  mA  
at 2.7 V:  $I_{RED} = 210$  mA,  $I_S = 1.0$  mA  
Transmit Mode  
at 5 V:  $I_{RED} = 210$  mA,  $I_S = 5$  mA (Avg.)  
at 2.7 V:  $I_{RED} = 210$  mA,  $I_S = 3.5$  mA (Avg.) 14879

Figure 5.

## Recommended Solder Profiles

### Solder Profile for Sn/Pb Soldering

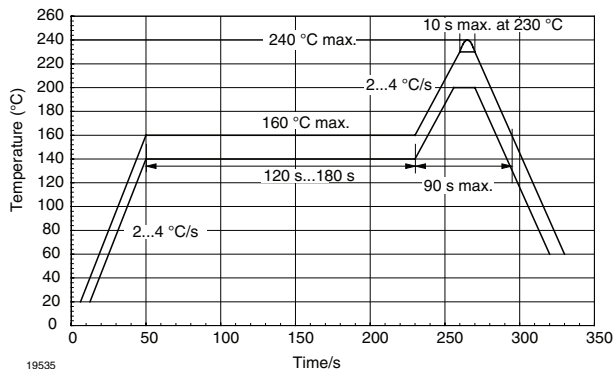

Figure 6. Recommended Solder Profile for Sn/Pb soldering

### Lead (Pb)-Free, Recommended Solder Profile

The TFDU4100 is a lead (Pb)-free transceiver and qualified for lead (Pb)-free processing. For lead (Pb)-free solder paste like Sn (3.0 - 4.0) Ag (0.5 - 0.9) Cu, there are two standard reflow profiles: Ramp-Soak-Spike (RSS) and Ramp-To-Spike (RTS). The Ramp-Soak-Spike profile was developed primarily for reflow ovens heated by infrared radiation. With widespread use of forced convection reflow ovens the Ramp-To-Spike profile is used increasingly. Shown below in figure 6 and 7 are VISHAY's recommended profiles for use with the TFDU4100 transceivers. For more details please refer to the application note "SMD Assembly Instructions" (<http://www.vishay.com/docs/82602/82602.pdf>).

A ramp-up rate less than 0.9 °C/s is not recommended. Ramp-up rates faster than 1.3 °C/s could damage an optical part because the thermal conductivity is less than compared to a standard IC.

### Wave Soldering

For TFDUxxxx and TFBSxxxx transceiver devices wave soldering is not recommended.

### Manual Soldering

Manual soldering is the standard method for lab use. However, for a production process it cannot be recommended because the risk of damage is quite highly depending on the experience of the operator. Nevertheless, we added a chapter to the above mentioned application note, describing manual soldering and desoldering.

### Storage

The storage and drying processes for all VISHAY transceivers (TFDUxxxx and TFBSxxx) are equivalent to MSL4.

The data for the drying procedure is given on labels on the packing and also in the application note "Taping, Labeling, Storage and Packing" (<http://www.vishay.com/docs/82601/82601.pdf>).

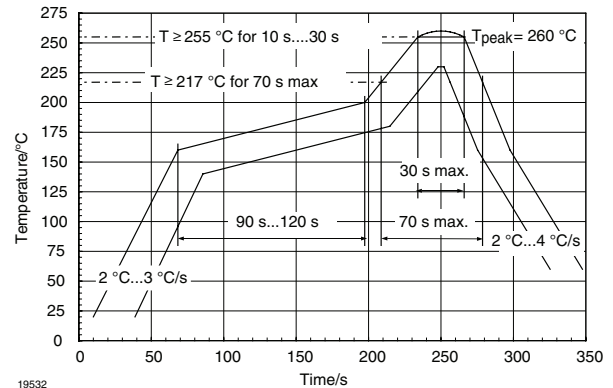

Figure 7. Solder Profile, RSS Recommendation

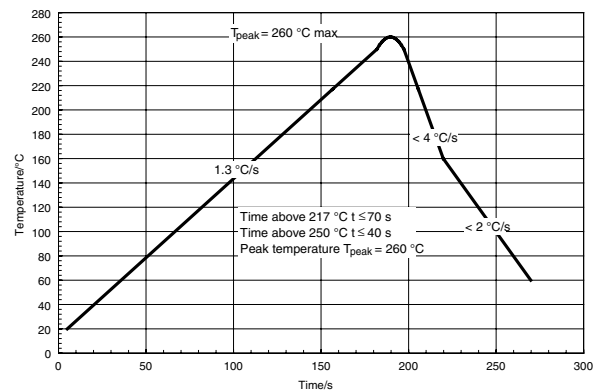

Figure 8. RTS Recommendation

### Current Derating Diagram

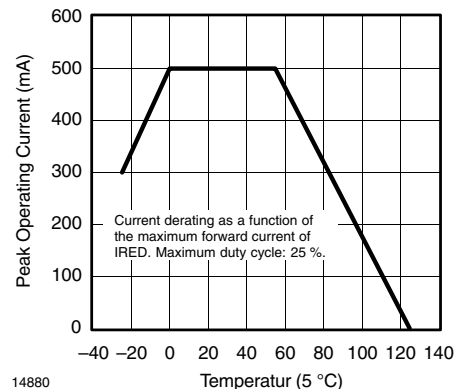

Figure 9. Current Derating Diagram

Package Dimensions

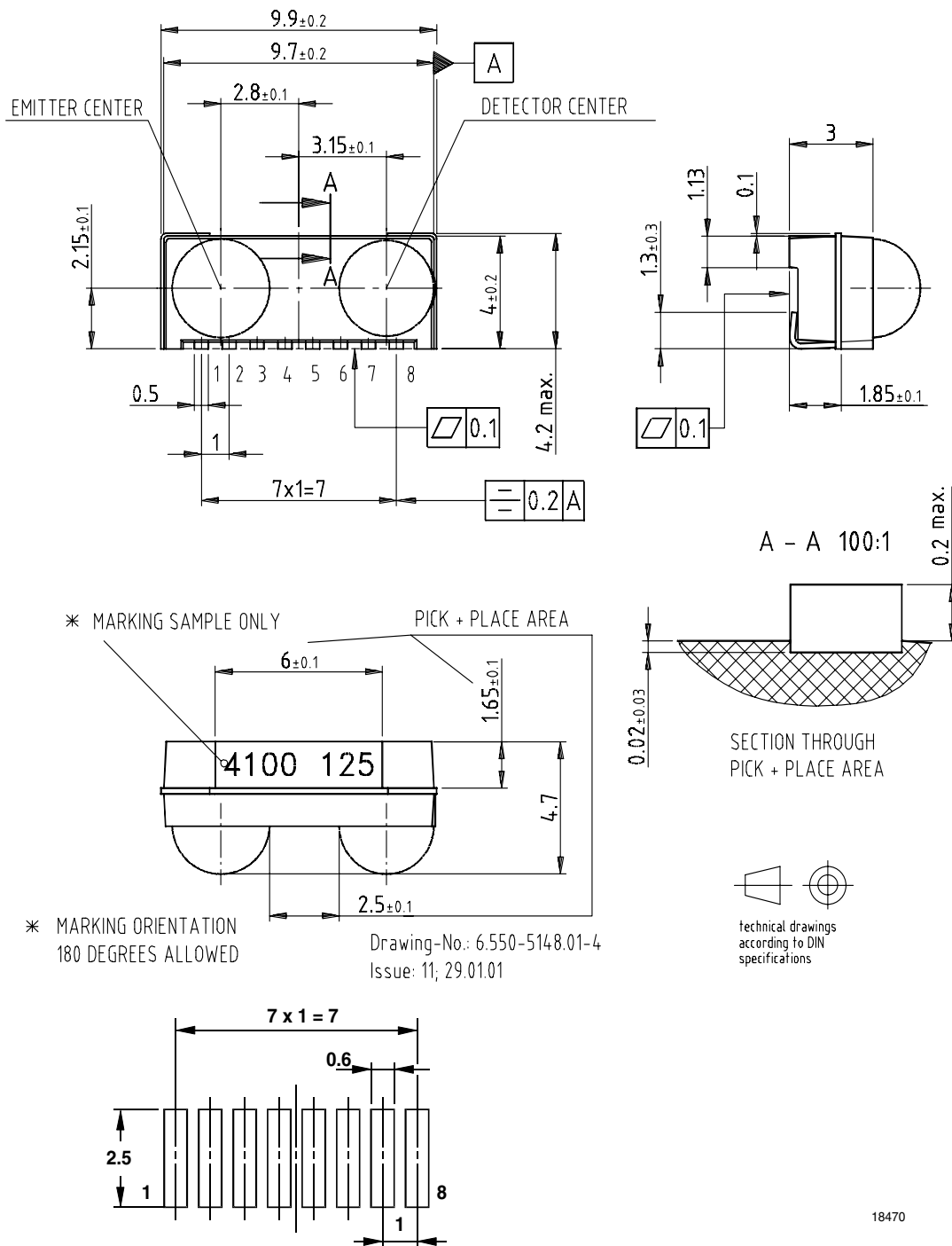
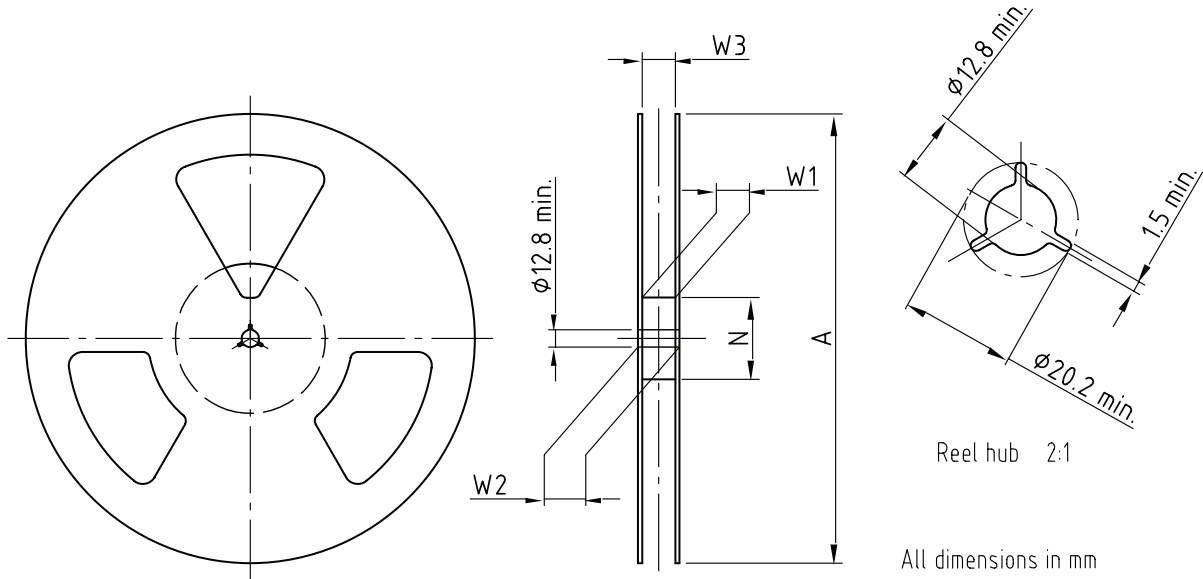

Figure 10. Package drawing and solder footprint TFDU4100, dimensions in mm, tolerance  $\pm 0.2$  mm if not otherwise mentioned

**Reel Dimensions**

Drawing-No.: 9.800-5090.01-4  
 Issue: 1; 29.11.05  
 14017

Form of the leave open  
 of the wheel is supplier specific.

Dimension acc. to IEC EN 60 286-3

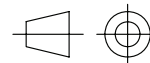

technical drawings  
 according to DIN  
 specifications

All dimensions in mm

Tape Width	A max.	N	$W_1$ min.	$W_2$ max.	$W_3$ min.	$W_3$ max.
mm	mm	mm	mm	mm	mm	mm
24	330	60	24.4	30.4	23.9	27.4



Tape Dimensions

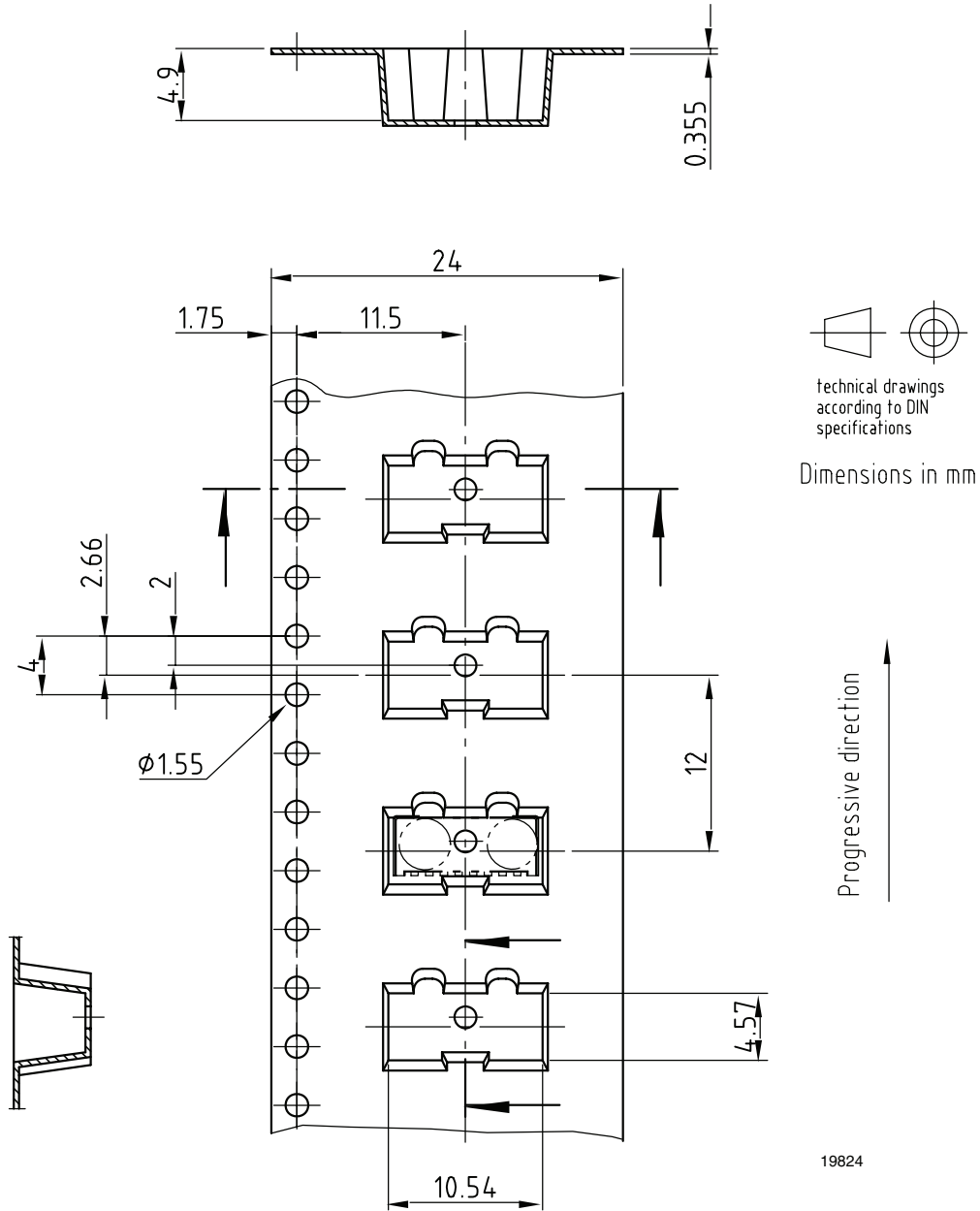

Drawing-No.: 9.700-5251.01-4  
Issue: 3; 02.09.05

Figure 11. Tape drawing, TFDU4100 for top view mounting, tolerance  $\pm 0.1$  mm

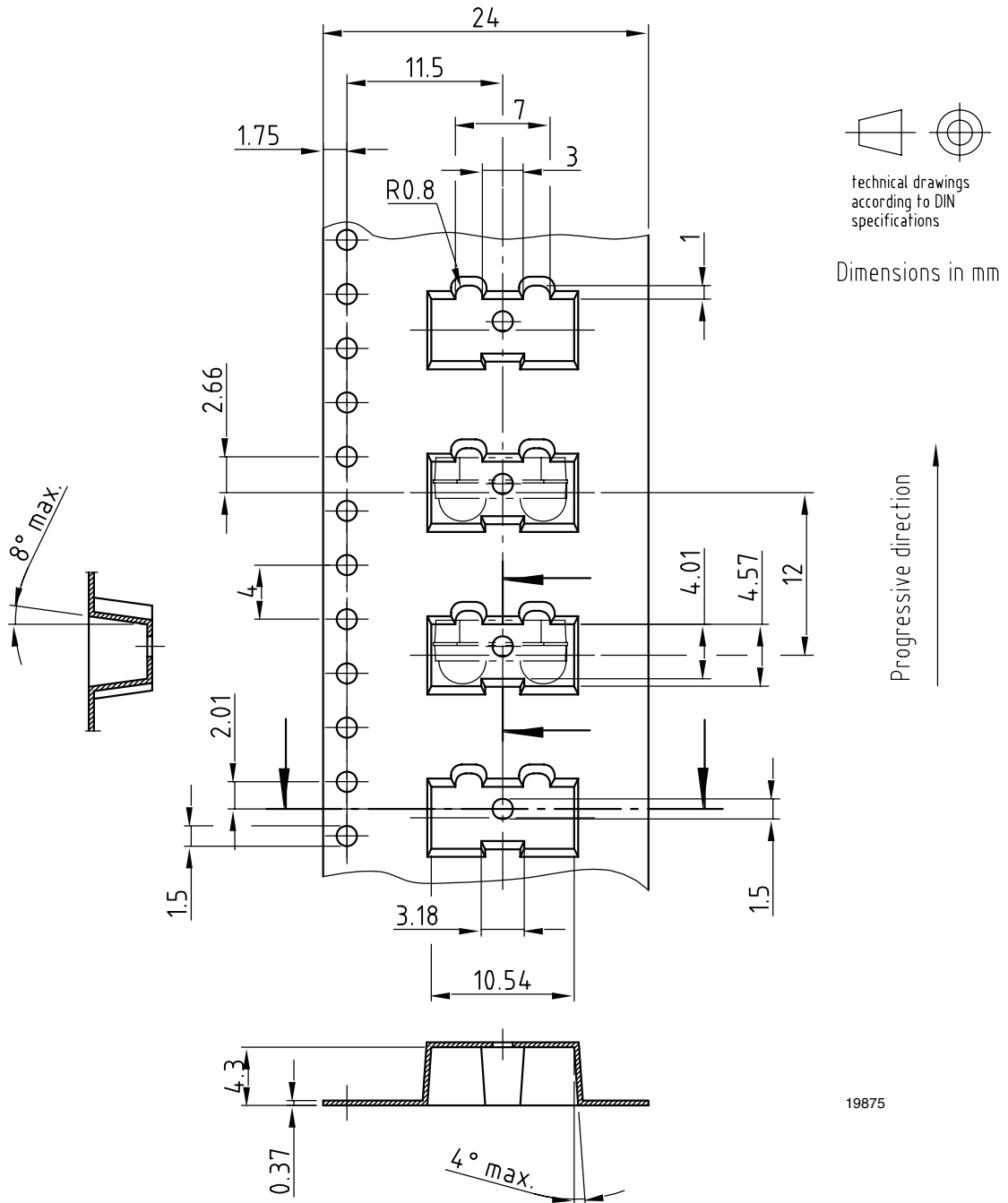

Drawing-No.: 9.700-5297.01-4  
Issue: 1; 08.04.05

Figure 12. Tape drawing, TFDU4100 for side view mounting, tolerance  $\pm 0.1$  mm

**Ozone Depleting Substances Policy Statement**

It is the policy of Vishay Semiconductor GmbH to

1. Meet all present and future national and international statutory requirements.
2. Regularly and continuously improve the performance of our products, processes, distribution and operating systems with respect to their impact on the health and safety of our employees and the public, as well as their impact on the environment.

It is particular concern to control or eliminate releases of those substances into the atmosphere which are known as ozone depleting substances (ODSs).

The Montreal Protocol (1987) and its London Amendments (1990) intend to severely restrict the use of ODSs and forbid their use within the next ten years. Various national and international initiatives are pressing for an earlier ban on these substances.

Vishay Semiconductor GmbH has been able to use its policy of continuous improvements to eliminate the use of ODSs listed in the following documents.

1. Annex A, B and list of transitional substances of the Montreal Protocol and the London Amendments respectively
2. Class I and II ozone depleting substances in the Clean Air Act Amendments of 1990 by the Environmental Protection Agency (EPA) in the USA
3. Council Decision 88/540/EEC and 91/690/EEC Annex A, B and C (transitional substances) respectively.

Vishay Semiconductor GmbH can certify that our semiconductors are not manufactured with ozone depleting substances and do not contain such substances.

We reserve the right to make changes to improve technical design  
and may do so without further notice.

Parameters can vary in different applications. All operating parameters must be validated for each customer application by the customer. Should the buyer use Vishay Semiconductors products for any unintended or unauthorized application, the buyer shall indemnify Vishay Semiconductors against all claims, costs, damages, and expenses, arising out of, directly or indirectly, any claim of personal damage, injury or death associated with such unintended or unauthorized use.

Vishay Semiconductor GmbH, P.O.B. 3535, D-74025 Heilbronn, Germany



### Notice

Specifications of the products displayed herein are subject to change without notice. Vishay Intertechnology, Inc., or anyone on its behalf, assumes no responsibility or liability for any errors or inaccuracies.

Information contained herein is intended to provide a product description only. No license, express or implied, by estoppel or otherwise, to any intellectual property rights is granted by this document. Except as provided in Vishay's terms and conditions of sale for such products, Vishay assumes no liability whatsoever, and disclaims any express or implied warranty, relating to sale and/or use of Vishay products including liability or warranties relating to fitness for a particular purpose, merchantability, or infringement of any patent, copyright, or other intellectual property right.

The products shown herein are not designed for use in medical, life-saving, or life-sustaining applications. Customers using or selling these products for use in such applications do so at their own risk and agree to fully indemnify Vishay for any damages resulting from such improper use or sale.