

TABLE OF CONTENTS

Features	1	Single Supply	4
Applications.....	1	Absolute Maximum Ratings	5
Functional Block Diagram	1	ESD Caution.....	5
General Description	1	Pin Configuration and Function Descriptions.....	6
Product Highlights	1	Typical Performance Characteristics	7
Revision History	2	Test Circuits.....	8
Specifications.....	3	Outline Dimensions	10
Dual Supply	3	Ordering Guide	10

REVISION HISTORY

7/10—Revision 0: Initial Version

SPECIFICATIONS

DUAL SUPPLY

$V_{DD} = 15\text{ V} \pm 10\%$, $V_{SS} = -15\text{ V} \pm 10\%$, $V_L = 5\text{ V} \pm 10\%$, $GND = 0\text{ V}$, unless otherwise noted.

Table 1.

Parameter	+25°C	-40°C to +85°C	-55°C to +125°C	Unit	Test Conditions/Comments
ANALOG SWITCH					
Analog Signal Range				V	
R_{ON}	25 35	45	45	Ω typ Ω max	$V_D = \pm 12.5\text{ V}$, $I_S = -10\text{ mA}$; see Figure 9 $V_{DD} = +13.5\text{ V}$, $V_{SS} = -13.5\text{ V}$; see Figure 9
LEAKAGE CURRENT					
Source Off Leakage, I_S (Off)	± 0.1 ± 0.25	± 5	± 15	nA typ nA max	$V_{DD} = +16.5\text{ V}$, $V_{SS} = -16.5\text{ V}$ $V_D = \pm 15.5\text{ V}$, $V_S = \mp 15.5\text{ V}$; see Figure 10
Drain Off Leakage, I_D (Off)	± 0.1 ± 0.75	± 5	± 30	nA typ nA max	$V_D = \pm 15.5\text{ V}$, $V_S = \mp 15.5\text{ V}$; see Figure 10
Channel On Leakage, I_D , I_S (On)	± 0.4 ± 0.75	± 5	± 30	nA typ nA max	$V_S = V_D = \pm 15.5\text{ V}$; see Figure 11
DIGITAL INPUTS					
Input High Voltage, V_{INH}		2.4	2.4	V min	
Input Low Voltage, V_{INL}		0.8	0.8	V max	
Input Current, I_{INL} or I_{INH}		± 0.005 ± 0.5	± 0.005 ± 0.5	μA typ μA max	$V_{IN} = V_{INL}$ or V_{INH}
DYNAMIC CHARACTERISTICS¹					
$t_{TRANSITION}$	145	200	200	ns max	$R_L = 300\ \Omega$, $C_L = 35\text{ pF}$; $V_{S1} = \pm 10\text{ V}$, $V_{S2} = \mp 10\text{ V}$; see Figure 12
Break-Before-Make Time Delay, t_D	30			ns typ	$R_L = 300\ \Omega$, $C_L = 35\text{ pF}$; $V_{S1} = V_{S2} = \pm 10\text{ V}$; see Figure 13
Off Isolation	5 80			ns min dB typ	$R_L = 50\ \Omega$, $f = 1\text{ MHz}$; see Figure 14
Channel-to-Channel Crosstalk	90			dB typ	$R_L = 50\ \Omega$, $f = 1\text{ MHz}$; see Figure 15
C_S (Off)	6			pF typ	$f = 1\text{ MHz}$
C_D , C_S (On)	55			pF typ	$f = 1\text{ MHz}$
POWER REQUIREMENTS					
I_{DD}	0.0001 1	2.5	2.5	μA typ μA max	$V_{DD} = +16.5\text{ V}$, $V_{SS} = -16.5\text{ V}$ $V_{IN} = 0\text{ V}$ or 5 V
I_{SS}	0.0001 1	2.5	2.5	μA typ μA max	
I_L	0.0001 1	2.5	2.5	μA typ μA max	$V_L = 5.5\text{ V}$

¹ Guaranteed by design; not subject to production test.

ADG419-EP

SINGLE SUPPLY

$V_{DD} = 12\text{ V} \pm 10\%$, $V_{SS} = 0\text{ V}$, $V_L = 5\text{ V} \pm 10\%$, $GND = 0\text{ V}$, unless otherwise noted.

Table 2.

Parameter	+25°C	-40°C to +85°C	-55°C to +125°C	Unit	Test Conditions/Comments
ANALOG SWITCH					
Analogue Signal Range			0 to V_{DD}	V	
R_{ON}	40	60	70	Ω typ Ω max	$V_D = 3\text{ V}, 8.5\text{ V}, I_S = -10\text{ mA}$; see Figure 9 $V_{DD} = 10.8\text{ V}$; see Figure 9
LEAKAGE CURRENT					
Source Off Leakage, I_S (Off)	± 0.1			nA typ	$V_{DD} = 13.2\text{ V}$ $V_D = 12.2\text{ V}/1\text{ V}, V_S = 1\text{ V}/12.2\text{ V}$; see Figure 10
Drain Off Leakage, I_D (Off)	± 0.1	± 5	± 15	nA max	
Channel On Leakage, I_D, I_S (On)	± 0.1	± 5	± 30	nA typ	$V_D = 12.2\text{ V}/1\text{ V}, V_S = 1\text{ V}/12.2\text{ V}$; see Figure 10
	± 0.75	± 5	± 30	nA max	$V_S = V_D = 12.2\text{ V}/1\text{ V}$; see Figure 11
	± 0.4	± 5	± 30	nA typ	
	± 0.75	± 5	± 30	nA max	
DIGITAL INPUTS					
Input High Voltage, V_{INH}		2.4	2.4	V min	
Input Low Voltage, V_{INL}		0.8	0.8	V max	
Input Current, I_{INL} or I_{INH}		± 0.005	± 0.005	μA typ	$V_{IN} = V_{INL}$ or V_{INH}
		± 0.5	± 0.5	μA max	
DYNAMIC CHARACTERISTICS¹					
$t_{TRANSITION}$	170	250	250	ns max	$R_L = 300\ \Omega, C_L = 35\text{ pF}; V_{S1} = 0\text{ V}/8\text{ V}, V_{S2} = 8\text{ V}/0\text{ V}$; see Figure 12
Break-Before-Make Time Delay, t_D	60			ns typ	$R_L = 300\ \Omega, C_L = 35\text{ pF}; V_{S1} = V_{S2} = 8\text{ V}$; see Figure 13
Off Isolation	80			dB typ	$R_L = 50\ \Omega, f = 1\text{ MHz}$; see Figure 14
Channel-to-Channel Crosstalk	70			dB typ	$R_L = 50\ \Omega, f = 1\text{ MHz}$; see Figure 15
C_S (Off)	13			pF typ	$f = 1\text{ MHz}$
C_D, C_S (On)	65			pF typ	$f = 1\text{ MHz}$
POWER REQUIREMENTS					
I_{DD}	0.0001			μA typ	$V_{DD} = 13.2\text{ V}$ $V_{IN} = 0\text{ V}$ or 5 V
	1	2.5	2.5	μA max	
I_L	0.0001			μA typ	$V_L = 5.5\text{ V}$
	1	2.5	2.5	μA max	

¹ Guaranteed by design; not subject to production test.

ABSOLUTE MAXIMUM RATINGS

$T_A = 25^\circ\text{C}$, unless otherwise noted.

Table 3.

Parameter	Rating
V_{DD} to V_{SS}	44 V
V_{DD} to GND	-0.3 V to +25 V
V_{SS} to GND	+0.3 V to -25 V
V_L to GND	-0.3 V to $V_{DD} + 0.3$ V
Analog, Digital Inputs ¹	$V_{SS} - 2$ V to $V_{DD} + 2$ V or 30 mA, whichever occurs first
Continuous Current, Sx or D	30 mA
Peak Current, Sx or D (Pulsed at 1 ms, 10% Duty Cycle Maximum)	100 mA
Operating Temperature Range	-55°C to +125°C
Storage Temperature Range	-65°C to +150°C
Junction Temperature	150°C
Power Dissipation (MSOP)	315 mW
Thermal Impedance, θ_{JA}	205°C/W
Lead Temperature, Soldering	As per JEDEC J-STD-020

¹ Overvoltages at IN, Sx, or D are clamped by internal diodes. Limit current to the maximum ratings given.

Stresses above those listed under Absolute Maximum Ratings may cause permanent damage to the device. This is a stress rating only; functional operation of the device at these or any other conditions above those indicated in the operational section of this specification is not implied. Exposure to absolute maximum rating conditions for extended periods may affect device reliability.

Only one maximum rating may be applied at any one time.

ESD CAUTION



ESD (electrostatic discharge) sensitive device. Charged devices and circuit boards can discharge without detection. Although this product features patented or proprietary protection circuitry, damage may occur on devices subjected to high energy ESD. Therefore, proper ESD precautions should be taken to avoid performance degradation or loss of functionality.

ADG419-EP

PIN CONFIGURATION AND FUNCTION DESCRIPTIONS

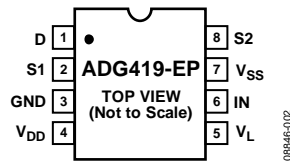

Figure 2. Pin Configuration

Table 4. Pin Function Descriptions

Pin No.	Mnemonic	Description
1	D	Drain Terminal. Can be an input or an output.
2	S1	Source Terminal. Can be an input or an output.
3	GND	Ground Reference (0 V).
4	V _{DD}	Most Positive Power Supply Potential.
5	V _L	Logic Power Supply (5 V).
6	IN	Logic Control Input.
7	V _{SS}	Most Negative Power Supply Potential in Dual-Supply Applications. In single-supply applications, this pin can be connected to GND.
8	S2	Source Terminal. Can be an input or an output.

Table 5. Truth Table

Logic	Switch 1	Switch 2
0	On	Off
1	Off	On

TYPICAL PERFORMANCE CHARACTERISTICS

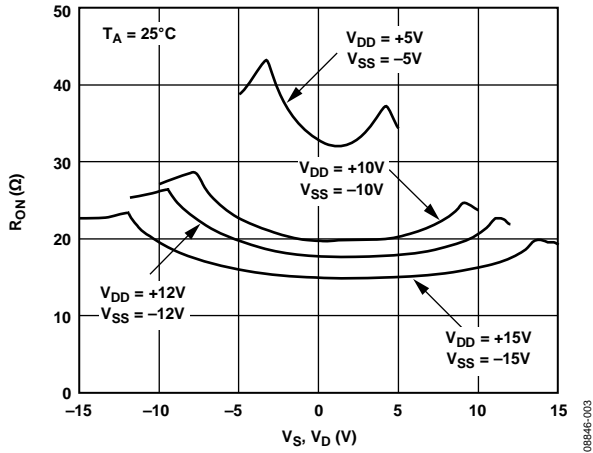

Figure 3. R_{ON} as a Function of V_D (V_S), Dual-Supply Voltage

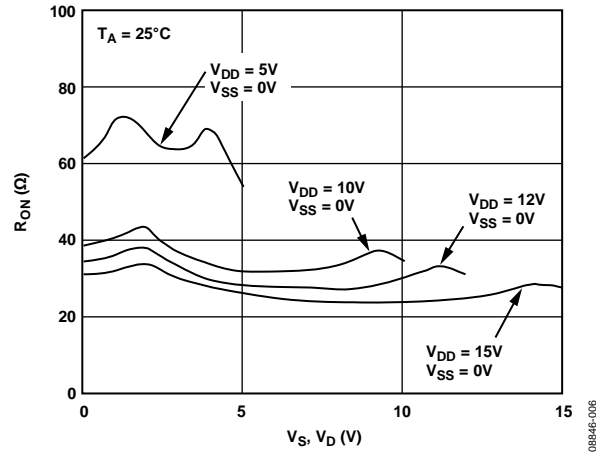

Figure 6. R_{ON} as a Function of V_D (V_S), Single-Supply Voltage

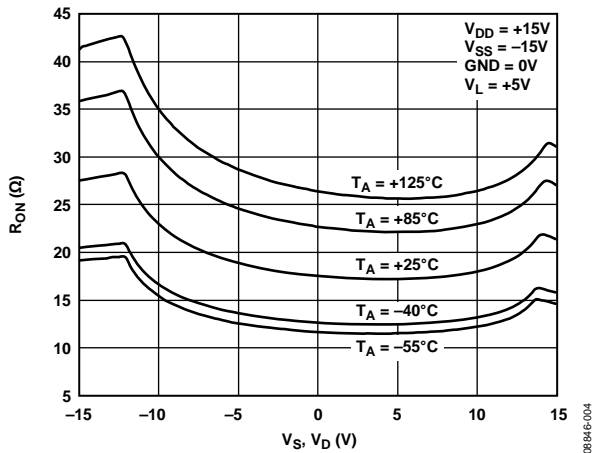

Figure 4. R_{ON} as a Function of V_D (V_S) for Different Temperatures, Dual-Supply Voltage

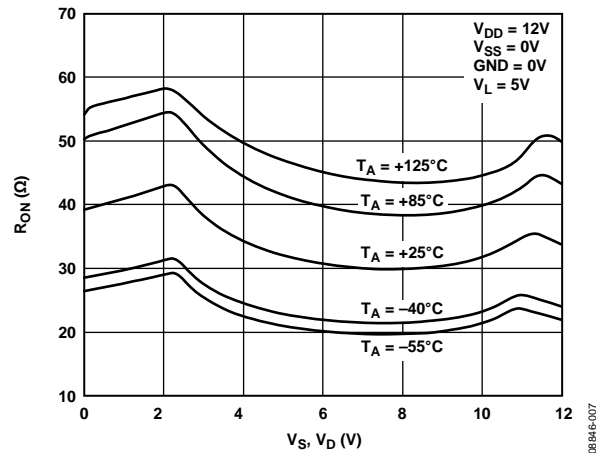

Figure 7. R_{ON} as a Function of V_D (V_S) for Different Temperatures, Single-Supply Voltage

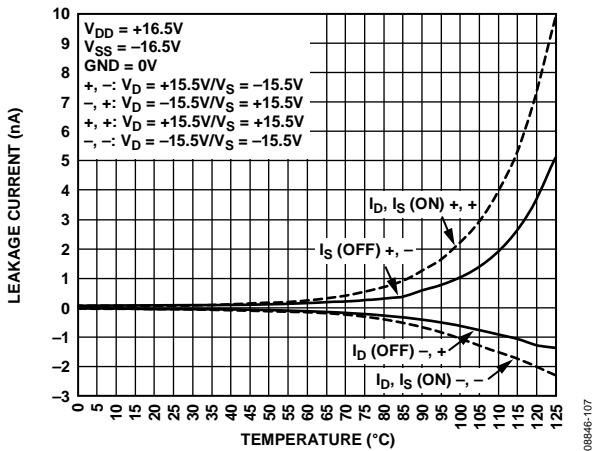

Figure 5. Leakage Current vs. Temperature, Dual-Supply Voltage

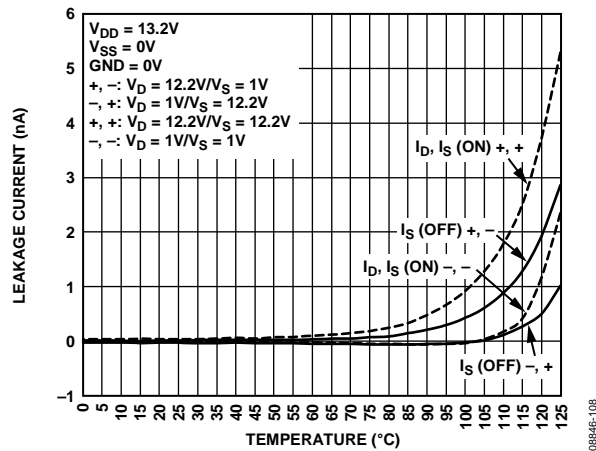

Figure 8. Leakage Current vs. Temperature, Single-Supply Voltage

TEST CIRCUITS

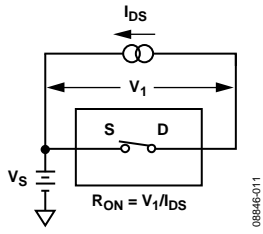

Figure 9. On Resistance

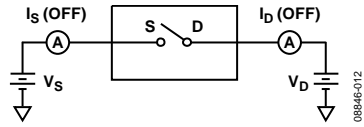

Figure 10. Off Leakage

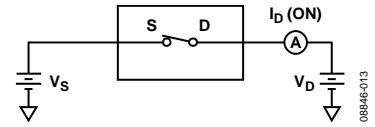

Figure 11. On Leakage

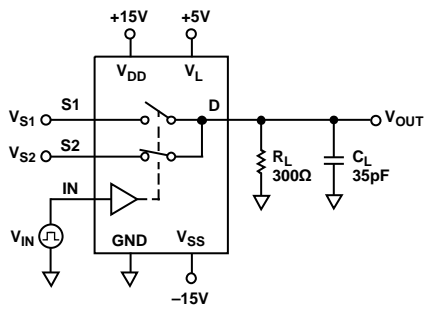

Figure 12. Transition Time, $t_{\text{TRANSITION}}$

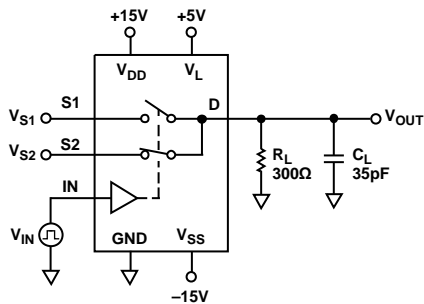
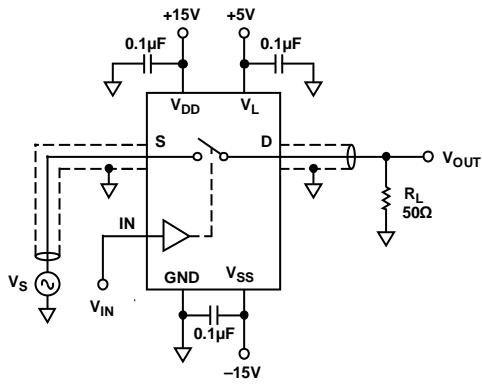
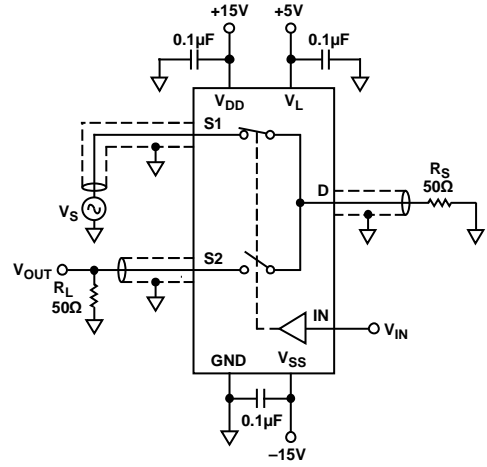

Figure 13. Break-Before-Make Time Delay, t_D



08846-016

Figure 14. Off Isolation



08846-017

CHANNEL-TO-CHANNEL CROSSTALK = $20 \times \log |V_S/V_{OUT}|$

Figure 15. Crosstalk

NOTES

ADG419-EP

NOTES