

**PIN CONFIGURATIONS**

**48-Pin mini BGA (6mm x 8mm)**

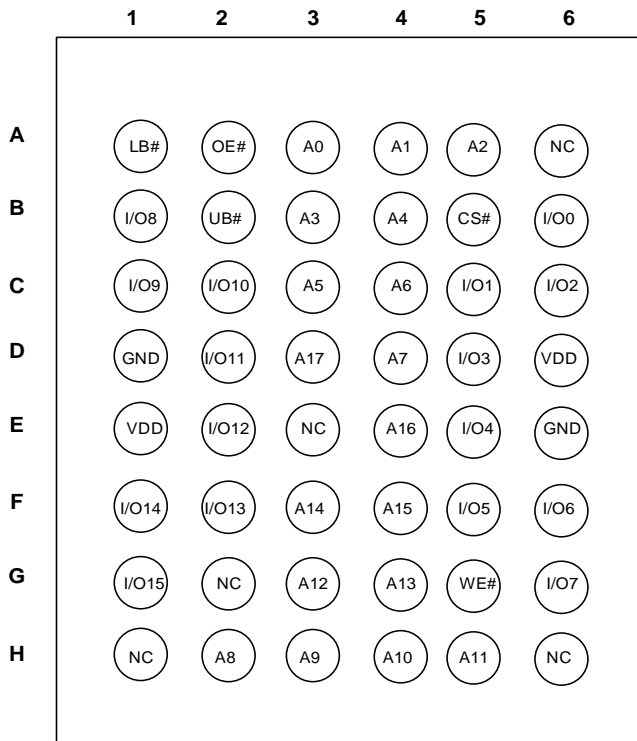

**48-Pin mini BGA (6mm x 8mm)**  
**2 CS Option**

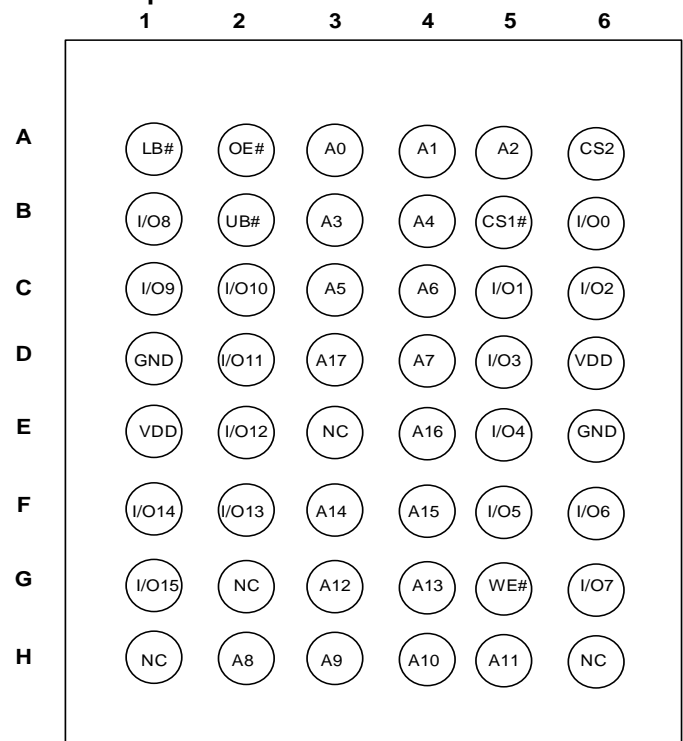

**PIN DESCRIPTIONS**

A0-A17	Address Inputs
I/O0-I/O15	Data Inputs/Outputs
CS1#, CS2	Chip Enable Input
CS#	Chip Enable Input
OE#	Output Enable Input
WE#	Write Enable Input
LB#	Lower-byte Control (I/O0-I/O7)
UB#	Upper-byte Control (I/O8-I/O15)
NC	No Connection
VDD	Power
GND	Ground

**44-Pin mini TSOP (Type II)**

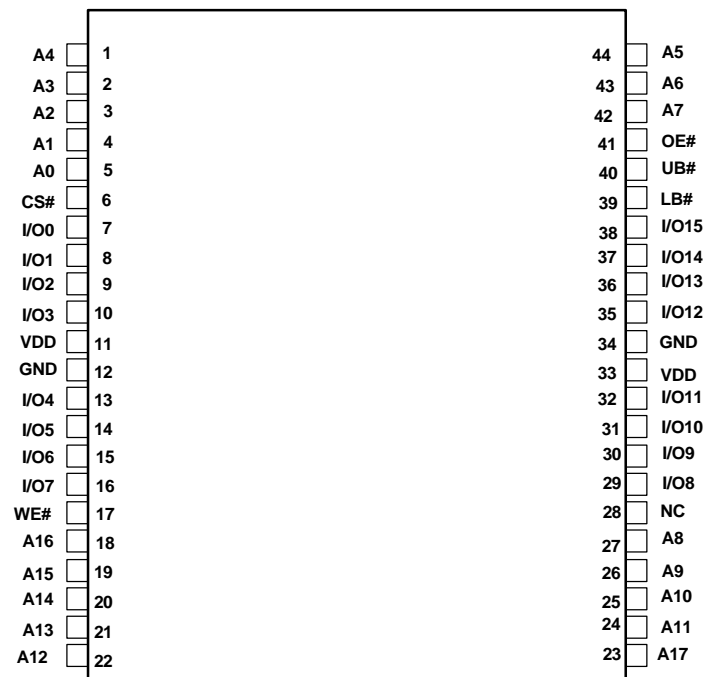

## FUNCTION DESCRIPTION

SRAM is one of random access memories. Each byte or word has an address and can be accessed randomly. SRAM has three different modes supported. Each function is described below with Truth Table. Below description is based on the device with 2 CS inputs.

### STANDBY MODE

Device enters standby mode when deselected (CS1# HIGH or CS2 LOW or both UB# and LB# are HIGH). The input and output pins (I/O0-15) are placed in a high impedance state. The current consumption in this mode will be ISB1 or ISB2. CMOS input in this mode will maximize saving power.

### WRITE MODE

Write operation issues with Chip selected (CS1# LOW and CS2 HIGH) and Write Enable (WE#) input LOW. The input and output pins (I/O0-15) are in data input mode. Output buffers are closed during this time even if OE# is LOW. UB# and LB# enables a byte write feature. By enabling LB# LOW, data from I/O pins (I/O0 through I/O7) are written into the location specified on the address pins. And with UB# being LOW, data from I/O pins (I/O8 through I/O15) are written into the location.

### READ MODE

Read operation issues with Chip selected (CS1# LOW and CS2 HIGH) and Write Enable (WE#) input HIGH. When OE# is LOW, output buffer turns on to make data output. Any input to I/O pins during READ mode is not permitted. UB# and LB# enables a byte read feature. By enabling LB# LOW, data from memory appears on I/O0-7. And with UB# being LOW, data from memory appears on I/O8-15.

In the READ mode, output buffers can be turned off by pulling OE# HIGH. In this mode, internal device operates as READ but I/Os are in a high impedance state. Since device is in READ mode, active current is used.

### TRUTH TABLE

Mode	CS1#	CS2	WE#	OE#	LB#	UB#	I/O0-I/O7	I/O8-I/O15	VDD Current
Not Selected	H	X	X	X	X	X	High-Z	High-Z	ISB2
	X	L	X	X	X	X	High-Z	High-Z	
	X	X	X	X	H	H	High-Z	High-Z	
Output Disabled	L	H	H	H	L	X	High-Z	High-Z	ICC,ICC1
	L	H	H	H	X	L	High-Z	High-Z	
Read	L	H	H	L	L	H	DOUT	High-Z	ICC,ICC1
	L	H	H	L	H	L	High-Z	DOUT	
	L	H	H	L	L	L	DOUT	DOUT	
Write	L	H	L	X	L	H	DIN	High-Z	ICC,ICC1
	L	H	L	X	H	L	High-Z	DIN	
	L	H	L	X	L	L	DIN	DIN	

Note:

1. Truth table for the device with 1 CS input is the same with the above table without CS2 column.

# IS62WV25616EALL/EBLL/ECLL IS65WV25616EBLL/ECLL



## ABSOLUTE MAXIMUM RATINGS AND OPERATING RANGE

### ABSOLUTE MAXIMUM RATINGS<sup>(1)</sup>

Symbol	Parameter	Value	Unit
V <sub>term</sub>	Terminal Voltage with Respect to GND	-0.5 to V <sub>DD</sub> + 0.5V	V
V <sub>DD</sub>	V <sub>DD</sub> Related to GND	-0.3 to 4.0	V
t <sub>Stg</sub>	Storage Temperature	-65 to +150	°C
P <sub>T</sub>	Power Dissipation	1.0	W

Notes:

1. Stress greater than those listed under ABSOLUTE MAXIMUM RATINGS may cause permanent damage to the device. This is a stress rating only and functional operation of the device at these or any other conditions above those indicated in the operational sections of this specification is not implied. Exposure to absolute maximum rating conditions for extended periods may affect reliability.

### OPERATING RANGE<sup>(1)</sup>

Range	Ambient Temperature	Part Number	SPEED (max)	VDD(min)	VDD(typ)	VDD(max)
Commercial	0°C to +70°C	~EALL	55 ns	1.65V	1.8V	2.2V
Industrial	-40°C to +85°C		55 ns	1.65V	1.8V	2.2V
Automotive	-40°C to +125°C		55 ns	1.65V	1.8V	2.2V
Commercial	0°C to +70°C	~EBLL	45ns	2.2V	3.0V	3.6V
Industrial	-40°C to +85°C		45ns	2.2V	3.0V	3.6V
Automotive	-40°C to +125°C		55ns	2.2V	3.0V	3.6V
Commercial	0°C to +70°C	~ECLL	35ns	3.135V	3.3V	3.465V
Industrial	-40°C to +85°C		35ns	3.135V	3.3V	3.465V
Automotive	-40°C to +125°C		45ns	3.135V	3.3V	3.465V

Note:

1. Full device AC operation assumes a 100 μs ramp time from 0 to V<sub>cc</sub>(min) and 200 μs wait time after V<sub>cc</sub> stabilization.

### PIN CAPACITANCE<sup>(1)</sup>

Parameter	Symbol	Test Condition	Max	Units
Input capacitance	C <sub>IN</sub>	T <sub>A</sub> = 25°C, f = 1 MHz, V <sub>DD</sub> = V <sub>DD</sub> (typ)	6	pF
DQ capacitance (IO0–IO15)	C <sub>I/O</sub>		8	pF

Note:

1. These parameters are guaranteed by design and tested by a sample basis only.

### THERMAL CHARACTERISTICS<sup>(1)</sup>

Parameter	Symbol	Rating	Units
Thermal resistance from junction to ambient (airflow = 1m/s)	R <sub>θJA</sub>	TBD	°C/W
Thermal resistance from junction to pins	R <sub>θJB</sub>	TBD	°C/W
Thermal resistance from junction to case	R <sub>θJC</sub>	TBD	°C/W

Note:

2. These parameters are guaranteed by design and tested by a sample basis only.

AC TEST CONDITIONS (OVER THE OPERATING RANGE)

Parameter	Unit (1.65V~2.2V)	Unit (2.2V~3.6V)	Unit (3.3V +/-5%)
Input Pulse Level	0V to V <sub>DD</sub>	0V to V <sub>DD</sub>	0V to V <sub>DD</sub>
Input Rise and Fall Time	1V/ns	1V/ns	1V/ns
Output Timing Reference Level	0.9V	½ V <sub>DD</sub>	½ V <sub>DD</sub> + 0.05V
R1	13500	1005	1213
R2	10800	820	1378
V <sub>TM</sub>	1.8V	V <sub>DD</sub>	V <sub>DD</sub>
Output Load Conditions	Refer to Figure 1 and 2		

OUTPUT LOAD CONDITIONS FIGURES

FIGURE 1

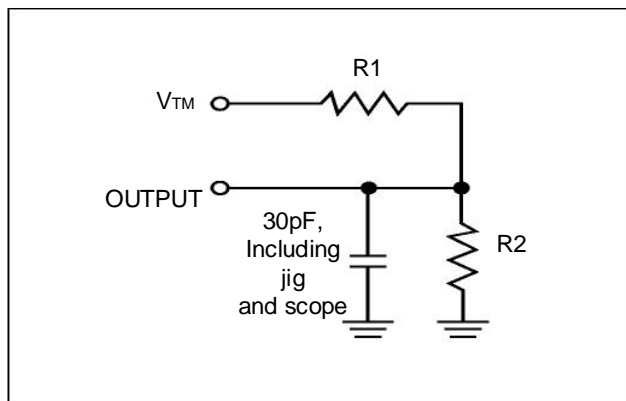
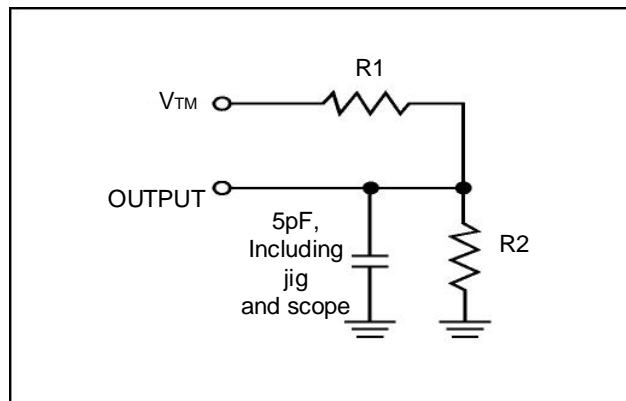

FIGURE 2



# IS62WV25616EALL/EBLL/ECLL IS65WV25616EBLL/ECLL



## DC ELECTRICAL CHARACTERISTICS

### IS62(5)WV25616EALL DC ELECTRICAL CHARACTERISTICS-I (OVER THE OPERATING RANGE)

VDD = 1.65V ~ 2.2V

Symbol	Parameter	Test Conditions	Min	Max	Unit
V <sub>OH</sub>	Output HIGH Voltage	I <sub>OH</sub> = -0.1 mA	1.4	—	V
V <sub>OL</sub>	Output LOW Voltage	I <sub>OL</sub> = 0.1 mA	—	0.2	V
V <sub>IH</sub> ( <sup>1</sup> )	Input HIGH Voltage		1.4	V <sub>DD</sub> + 0.2	V
V <sub>IL</sub> ( <sup>1</sup> )	Input LOW Voltage		-0.2	0.4	V
I <sub>LI</sub>	Input Leakage	GND < V <sub>IN</sub> < V <sub>DD</sub>	-1	1	μA
I <sub>LO</sub>	Output Leakage	GND < V <sub>IN</sub> < V <sub>DD</sub> , Output Disabled	-1	1	μA

Notes:

- V<sub>ILL</sub>(min) = -1.0V AC (pulse width < 10ns). Not 100% tested.  
V<sub>IHH</sub>(max) = V<sub>DD</sub> + 1.0V AC (pulse width < 10ns). Not 100% tested.

### IS62(5)WV25616EBLL DC ELECTRICAL CHARACTERISTICS-I (OVER THE OPERATING RANGE)

VDD = 2.2V ~ 3.6V

Symbol	Parameter	Test Conditions	Min	Max	Unit
V <sub>OH</sub>	Output HIGH Voltage	2.2 ≤ V <sub>DD</sub> < 2.7, I <sub>OH</sub> = -0.1 mA	2.0	—	V
		2.7 ≤ V <sub>DD</sub> ≤ 3.6, I <sub>OH</sub> = -1.0 mA	2.4	—	V
V <sub>OL</sub>	Output LOW Voltage	2.2 ≤ V <sub>DD</sub> < 2.7, I <sub>OL</sub> = 0.1 mA	—	0.4	V
		2.7 ≤ V <sub>DD</sub> ≤ 3.6, I <sub>OL</sub> = 2.1 mA	—	0.4	V
V <sub>IH</sub> ( <sup>1</sup> )	Input HIGH Voltage	2.2 ≤ V <sub>DD</sub> < 2.7	1.8	V <sub>DD</sub> + 0.3	V
		2.7 ≤ V <sub>DD</sub> ≤ 3.6	2.0	V <sub>DD</sub> + 0.3	V
V <sub>IL</sub> ( <sup>1</sup> )	Input LOW Voltage	2.2 ≤ V <sub>DD</sub> < 2.7	-0.3	0.6	V
		2.7 ≤ V <sub>DD</sub> ≤ 3.6	-0.3	0.8	V
I <sub>LI</sub>	Input Leakage	GND < V <sub>IN</sub> < V <sub>DD</sub>	-1	1	μA
I <sub>LO</sub>	Output Leakage	GND < V <sub>IN</sub> < V <sub>DD</sub> , Output Disabled	-1	1	μA

Notes:

- V<sub>ILL</sub>(min) = -2.0V AC (pulse width < 10ns). Not 100% tested.  
V<sub>IHH</sub>(max) = V<sub>DD</sub> + 2.0V AC (pulse width < 10ns). Not 100% tested.

### IS62(5)WV25616ECLL DC ELECTRICAL CHARACTERISTICS-I (OVER THE OPERATING RANGE)

VDD = 3.3V +/-5%<sup>(2)</sup>

Symbol	Parameter	Test Conditions	Min	Max	Unit
V <sub>OH</sub>	Output HIGH Voltage	I <sub>OH</sub> = -1.0 mA	2.4	—	V
V <sub>OL</sub>	Output LOW Voltage	I <sub>OL</sub> = 2.1 mA	—	0.4	V
V <sub>IH</sub> ( <sup>1</sup> )	Input HIGH Voltage		2.0	V <sub>DD</sub> + 0.3	V
V <sub>IL</sub> ( <sup>1</sup> )	Input LOW Voltage		-0.3	0.8	V
I <sub>LI</sub>	Input Leakage	GND < V <sub>IN</sub> < V <sub>DD</sub>	-1	1	μA
I <sub>LO</sub>	Output Leakage	GND < V <sub>IN</sub> < V <sub>DD</sub> , Output Disabled	-1	1	μA

Notes:

- V<sub>ILL</sub>(min) = -2.0V AC (pulse width < 10ns). Not 100% tested.  
V<sub>IHH</sub>(max) = V<sub>DD</sub> + 2.0V AC (pulse width < 10ns). Not 100% tested.
- V<sub>DD</sub>=3.3V +/-5% is for high speed of 35ns device (ECLL).

**IS62WV25616EALL/EBLL/ECLL**  
**IS65WV25616EBLL/ECLL**



**IS62(5)WV25616EALL DC ELECTRICAL CHARACTERISTICS-II FOR POWER**  
**(OVER THE OPERATING RANGE)**

Symbol	Parameter	Test Conditions	Grade	55ns		Unit	
				Typ <sup>(1)</sup>	Max		
ICC	V <sub>DD</sub> Dynamic Operating Supply Current	V <sub>DD</sub> =V <sub>DD</sub> (max), I <sub>OUT</sub> =0mA, f = f <sub>max</sub> CS1# = V <sub>IL</sub> , CS2 = V <sub>IH</sub>	Com.	-	20	mA	
			Ind.	-	22		
			Auto. A3	-	22		
ICC1	V <sub>DD</sub> Static Operating Supply Current	V <sub>DD</sub> =V <sub>DD</sub> (max), I <sub>OUT</sub> = 0mA, f=0 CS1# = V <sub>IL</sub> , CS2 = V <sub>IH</sub>	Com.	-	5	mA	
			Ind.	-	5		
			Auto. A3	-	5		
ISB2	CMOS Standby Current (CMOS Inputs)	V <sub>DD</sub> = V <sub>DD</sub> (max), f = 0, CS1# ≥ V <sub>DD</sub> - 0.2V or 0V ≤ CS2 ≤ 0.2V or LB# and UB# ≥ V <sub>DD</sub> - 0.2V VIN ≤ 0.2V or VIN ≥ V <sub>DD</sub> - 0.2V	Com.	25°C	3.7	6	μA
				40°C	3.8	7	
				70°C	3.9	9	
			Ind.	85°C	4.1	10	
			Auto. A3	125°C	8.1	25	

Note:

1. Typical values are measured at V<sub>DD</sub> = 1.8V, and not 100% tested.

**IS62(5)WV25616EBLL/ECLL DC ELECTRICAL CHARACTERISTICS-II FOR POWER**  
**(OVER THE OPERATING RANGE)**

Symbol	Parameter	Test Conditions	Grade	35ns <sup>(1)</sup>		45/55ns		Unit	
				Typ <sup>(2)</sup>	Max	Typ <sup>(2)</sup>	Max		
ICC	V <sub>DD</sub> Dynamic Operating Supply Current	V <sub>DD</sub> =V <sub>DD</sub> (max), I <sub>OUT</sub> =0mA, f = f <sub>max</sub> CS1# = V <sub>IL</sub> , CS2 = V <sub>IH</sub>	Com.	-	22	-	20	mA	
			Ind.	-	25	-	22		
			Auto. A3	-	-	-	22		
ICC1	V <sub>DD</sub> Static Operating Supply Current	V <sub>DD</sub> =V <sub>DD</sub> (max), I <sub>OUT</sub> = 0mA, f=0 CS1# = V <sub>IL</sub> , CS2 = V <sub>IH</sub>	Com.	-	5	-	5	mA	
			Ind.	-	5	-	5		
			Auto. A3	-	-	-	5		
ISB2	CMOS Standby Current (CMOS Inputs)	V <sub>DD</sub> = V <sub>DD</sub> (max), f = 0, CS1# ≥ V <sub>DD</sub> - 0.2V or 0V ≤ CS2 ≤ 0.2V or LB# and UB# ≥ V <sub>DD</sub> - 0.2V VIN ≤ 0.2V or VIN ≥ V <sub>DD</sub> - 0.2V	Com.	25°C	3.7	6	3.7	6	μA
				40°C	3.8	7	3.8	7	
				70°C	3.9	9	3.9	9	
			Ind.	85°C	4.1	10	4.1	10	
			Auto. A3	125°C	8.1	25	8.1	25	

Notes:

1. 35 ns speed bin is for ECLL (V<sub>DD</sub>=3.3V +/-5%) only.
2. Typical values are measured at V<sub>DD</sub> = 3.0V, and not 100% tested.

**AC CHARACTERISTICS<sup>(6)</sup> (OVER OPERATING RANGE)**

**READ CYCLE AC CHARACTERISTICS**

Parameter	Symbol	35ns <sup>(7)</sup>		45ns		55ns		unit	notes
		Min	Max	Min	Max	Min	Max		
Read Cycle Time	tRC	35	-	45	-	55	-	ns	1,5
Address Access Time	tAA	-	35	-	45	-	55	ns	1
Output Hold Time	tOHA	8	-	10	-	10	-	ns	1
CS1#, CS2 Access Time	tACS1/ACS2	-	35	-	45	-	55	ns	1
UB#, LB# Access Time	tBA	-	35	-	45	-	55	ns	1
OE# Access Time	tDOE	-	18	-	20	-	25	ns	1
OE# to High-Z Output	tHZOE	-	12	-	15	-	20	ns	2
OE# to Low-Z Output	tLZOE	4	-	5	-	5	-	ns	2
CS1#, CS2 to High-Z Output	tHZCS	-	12	-	15	-	20	ns	2
CS1#, CS2 to Low-Z Output	tLZCS	10	-	10	-	10	-	ns	2
UB#, LB# to High-Z Output	tHZB	-	12	-	15	-	20	ns	2
UB#, LB# to Low-Z Output	tLZB	10	-	10	-	10	-	ns	2

**WRITE CYCLE AC CHARACTERISTICS**

Parameter	Symbol	35ns <sup>(7)</sup>		45ns		55ns		unit	notes
		Min	Max	Min	Max	Min	Min		
Write Cycle Time	tWC	35	-	45	-	55	-	ns	1,3,5
CS1#, CS2 to Write End	tSCS	30	-	35	-	40	-	ns	1,3
Address Setup Time to Write End	tAW	30	-	35	-	40	-	ns	1,3
UB#,LB# to Write End	tPWB	30	-	35	-	40	-	ns	1,3
Address Hold from Write End	tHA	0	-	0	-	0	-	ns	1,3
Address Setup Time	tSA	0	-	0	-	0	-	ns	1,3
WE# Pulse Width	tPWE	30	-	35	-	40	-	ns	1,3,4
Data Setup to Write End	tSD	18	-	20	-	25	-	ns	1,3
Data Hold from Write End	tHD	0	-	0	-	0	-	ns	1,3
WE# LOW to High-Z Output	tHZWE	-	12	-	15	-	20	ns	2,3
WE# HIGH to Low-Z Output	tLZWE	4	-	5	-	5	-	ns	2,3

Notes:

1. Tested with the load in Figure 1.
2. Tested with the load in Figure 2. Transition is measured  $\pm 500$  mV from steady-state voltage. tHZOE, tHZCS, tHZB, and tHZWE transitions are measured when the output enters a high impedance state. Not 100% tested.
3. The internal write time is defined by the overlap of CS1# = LOW, CS2=HIGH, UB# or LB# = LOW, and WE# = LOW. All four conditions must be in valid states to initiate a Write, but any condition can go inactive to terminate the Write. The Data Input Setup and Hold timing are referenced to the rising or falling edge of the signal that terminates the write.
4. tPWE > tHZWE + tSD when OE# is LOW.
5. Address inputs must meet V<sub>IH</sub> and V<sub>IL</sub> SPEC during this period. Any glitch or unknown inputs are not permitted. Unknown input with standby mode is acceptable.
6. Data retention characteristics are defined later in DATA RETENTION CHARACTERISTICS.
7. 35 ns speed bin is for ECLL (VDD=3.3V +/-5%) only .

## Timing Diagram

READ CYCLE NO. 1<sup>(1)</sup> (ADDRESS CONTROLLED, CS1# = OE# = UB# = LB# = LOW, CS2 = WE# = HIGH)

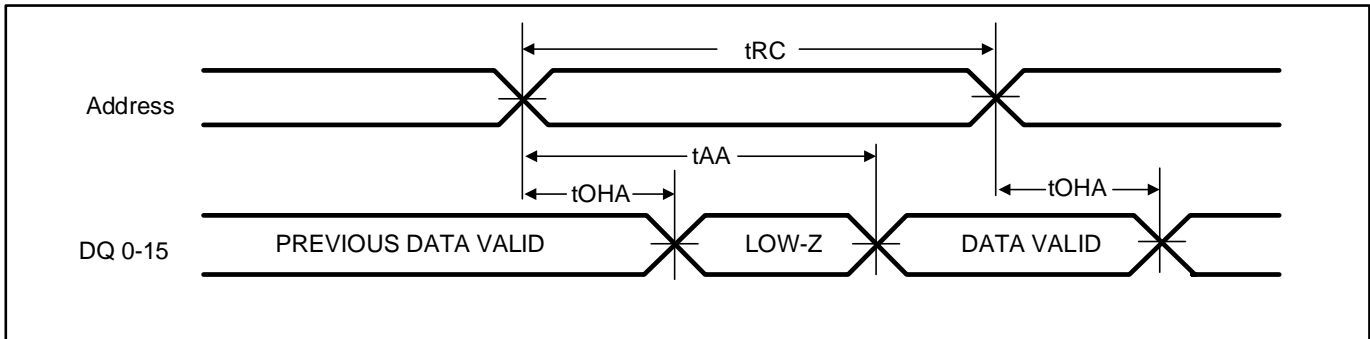

Notes:

1. The device is continuously selected.

READ CYCLE NO. 2<sup>(1)</sup> (OE# CONTROLLED, WE# = HIGH)

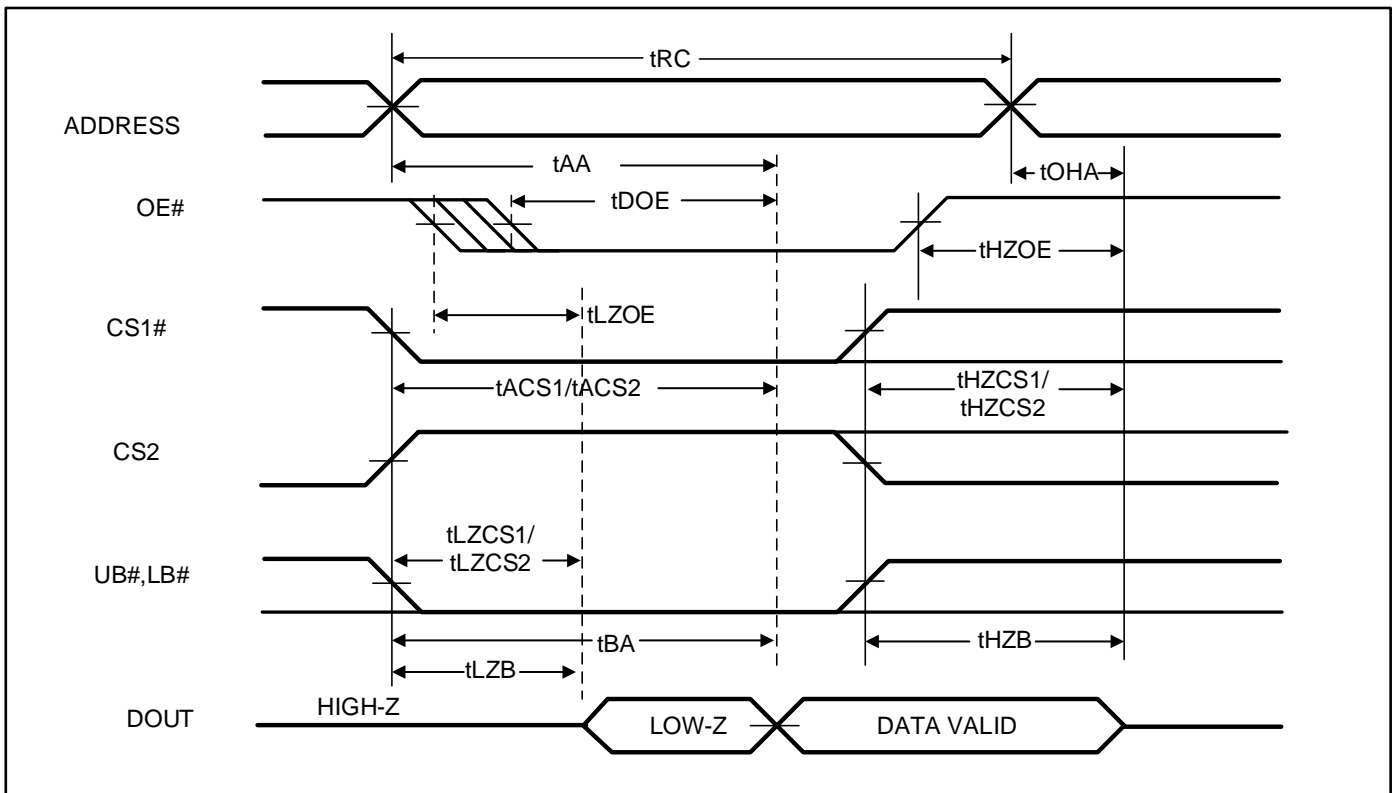

Notes:

1. Address is valid prior to or coincident with CS1# LOW or CS2# HIGH transition.



**WRITE CYCLE NO. 1<sup>(1,2)</sup> (CS1#, CS2 CONTROLLED, OE# = HIGH OR LOW)**

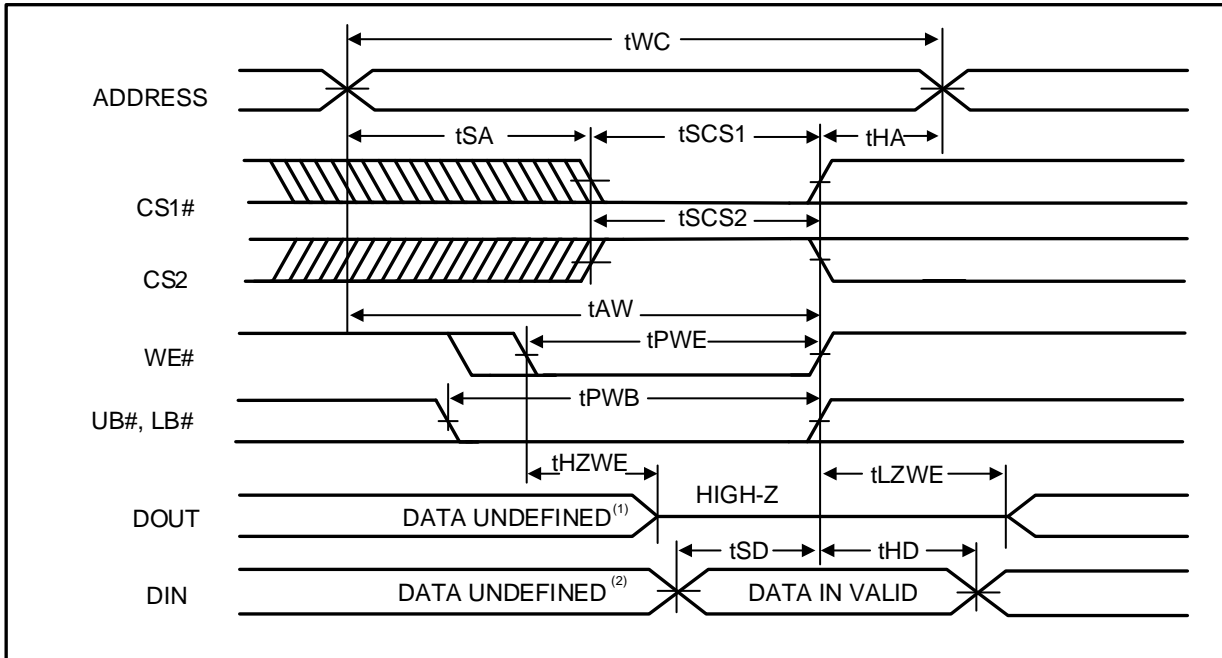

Notes:

1. tHZWE is based on the assumption when tSA=0nS after READ operation. Actual DOUT for tHZWE may not appear if OE# goes high before Write Cycle. tHZOE is the time DOUT goes to High-Z after OE# goes high.
2. During this period the I/Os are in output state. Do not apply input signals.

**WRITE CYCLE NO. 2<sup>(1,2)</sup> (WE# CONTROLLED: OE# IS HIGH DURING WRITE CYCLE)**

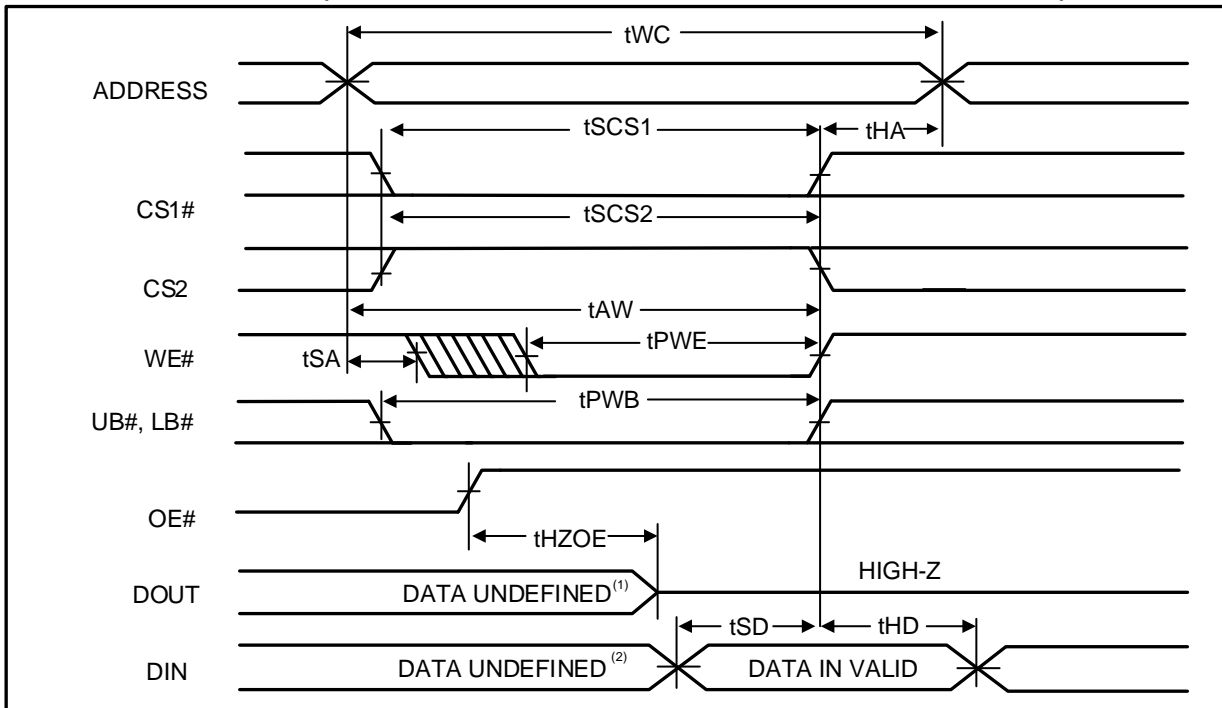

Notes:

1. tHZOE is the time DOUT goes to High-Z after OE# goes high.
2. During this period the I/Os are in output state. Do not apply input signals.

WRITE CYCLE NO. 3 (WE# CONTROLLED: OE# IS LOW DURING WRITE CYCLE)

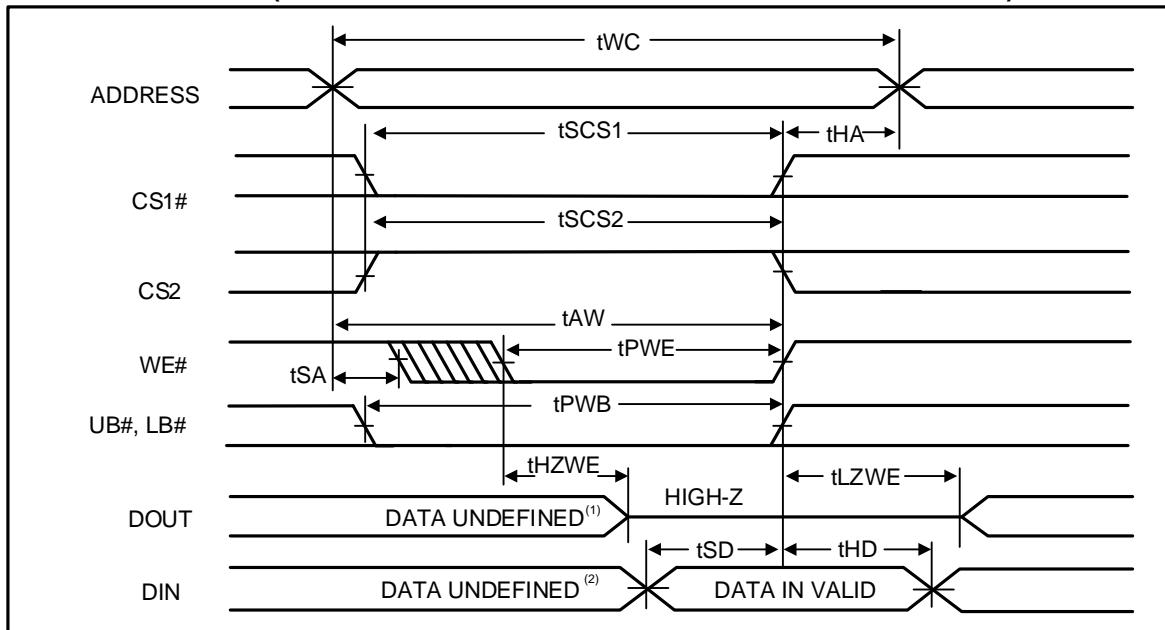

Note:

1. If OE# is low during write cycle,  $t_{HZWE}$  must be met in the application. Do not apply input signal during this period. Data output from the previous READ operation will drive IO BUS.

WRITE CYCLE NO. 4 (UB# & LB# Controlled, OE# = LOW)

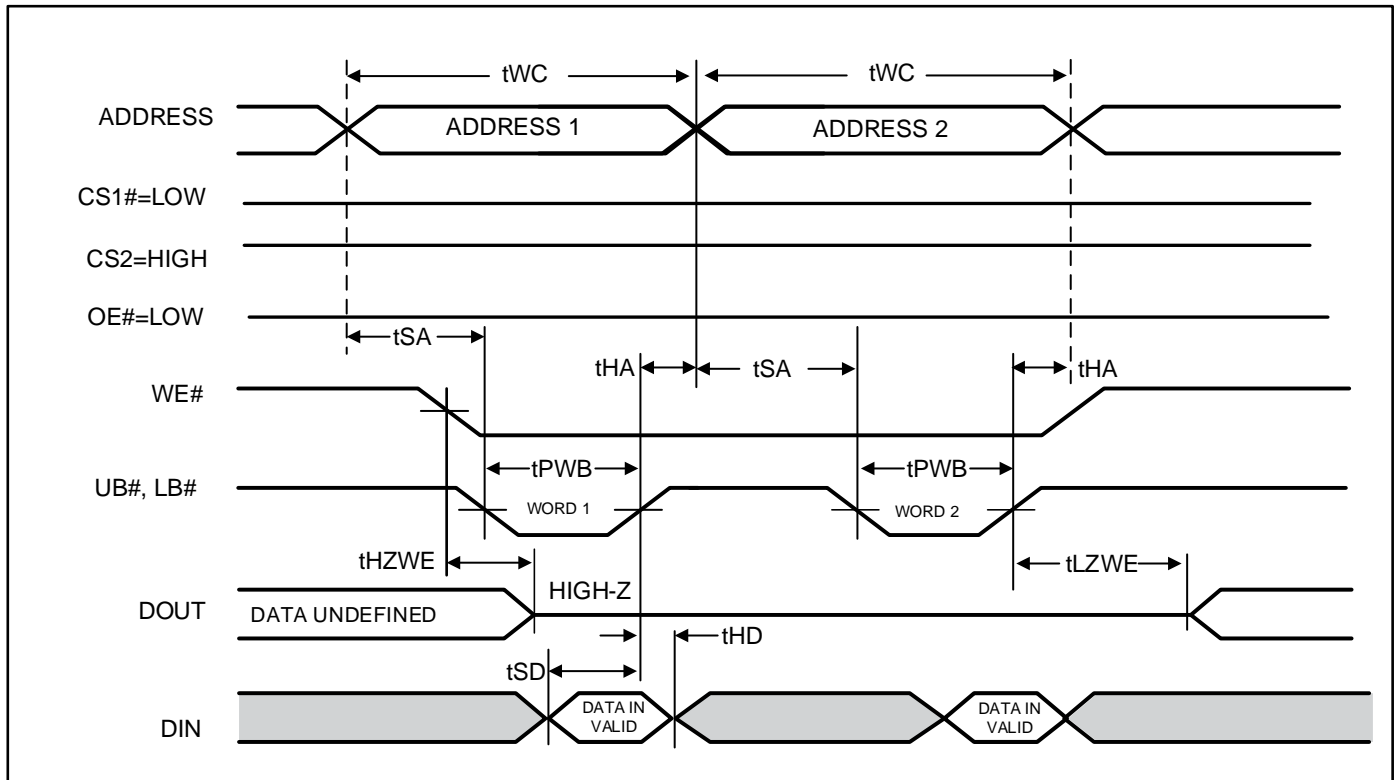

Notes:

1. If OE# is low during write cycle,  $t_{HZWE}$  must be met in the application. Do not apply input signal during this period. Data output from the previous READ operation will drive IO BUS.
2. Due to the restriction of note1, OE# is recommended to be HIGH during write period.
3. Note WE# stays LOW in this example. If WE# toggles,  $t_{PWE}$  and  $t_{HZWE}$  must be considered.

**DATA RETENTION CHARACTERISTICS**

Symbol	Parameter	Test Condition	OPTION	Min	Typ	Max	Unit
V <sub>DR</sub>	V <sub>DD</sub> for Data Retention	See Data Retention Waveform		1.5		3.6	V
I <sub>DR</sub>	Data Retention Current	V <sub>DD</sub> = V <sub>DR</sub> (min), CS1# ≥ V <sub>DD</sub> - 0.2V, <sup>(1)</sup> or 0V ≤ CS2 ≤ 0.2V, or LB# and UB# ≥ V <sub>DD</sub> - 0.2V, VIN ≤ 0.2V or VIN ≥ V <sub>DD</sub> - 0.2V	Com. Ind. Auto A3 typ. <sup>(2)</sup>	- - - -	- - - 3.6	9 10 25	uA
t <sub>SDR</sub>	Data Retention Setup Time	See Data Retention Waveform		0	-	-	ns
t <sub>RDR</sub>	Recovery Time	See Data Retention Waveform		t <sub>RC</sub>	-	-	ns

Note:

1. If CS1# > V<sub>DD</sub>-0.2V, all other inputs including CS2 and UB# and LB# must meet this condition.
2. Typical values are measured at V<sub>DD</sub>=1.8V or 3V, T<sub>A</sub> = 25°C, and not 100% tested.
3. V<sub>DD</sub> power down slope must be longer than 100 us/volt when enter into Data Retention Mode.

**DATA RETENTION WAVEFORM (CS1# CONTROLLED)**

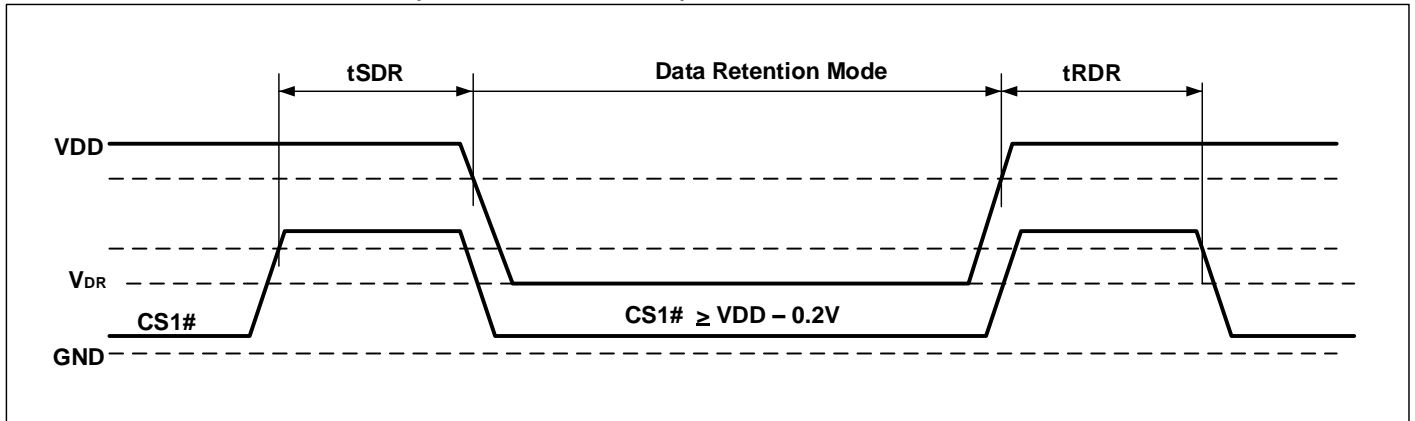

**DATA RETENTION WAVEFORM (CS2 CONTROLLED)**

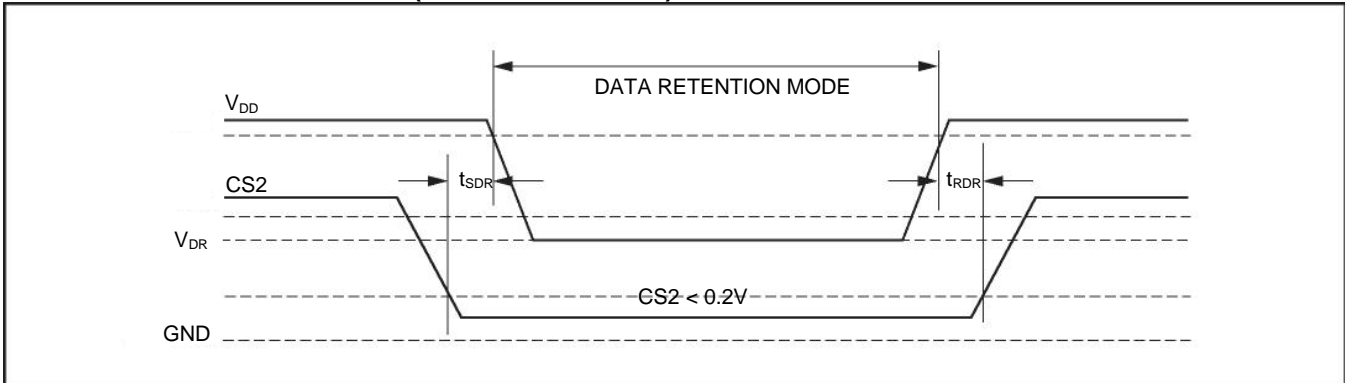

DATA RETENTION WAVEFORM (UB# AND LB# CONTROLLED)

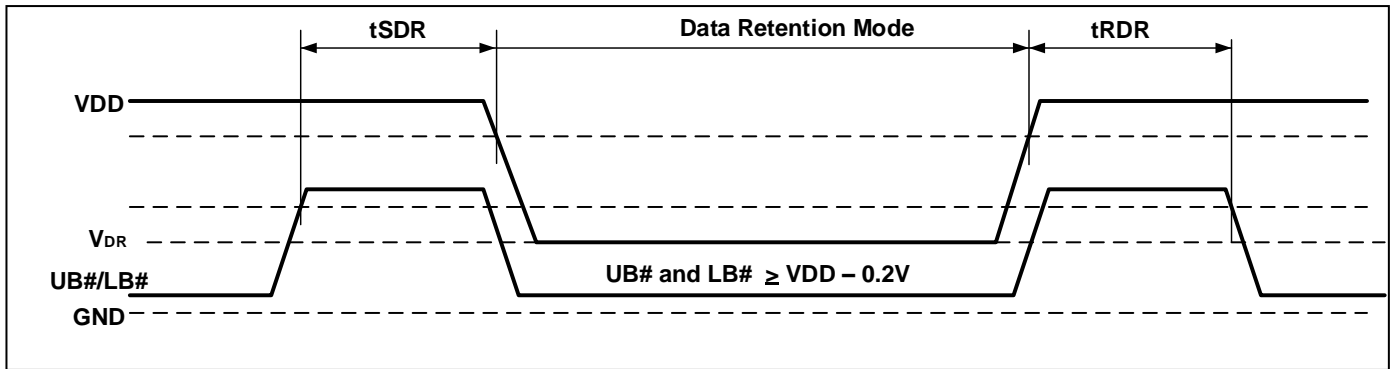

**Note:**

1. CS2 must satisfy either  $CS2 \geq VDD - 0.2V$  or  $CS2 \leq 0.2V$
2. CS1# must satisfy either  $CS1# \geq VDD - 0.2V$  or  $CS1# \leq 0.2V$

## ORDERING INFORMATION

### IS62WV25616EALL (1.65V - 2.2V)

Industrial Range: -40°C to +85°C

Speed (ns)	Order Part No.	Package
55	IS62WV25616EALL-55TI	TSOP (Type II)
55	IS62WV25616EALL-55TLI	TSOP (Type II), Lead-free
55	IS62WV25616EALL-55BI	mini BGA (6mm x 8mm)
55	IS62WV25616EALL-55B2I	mini BGA (6mm x 8mm), 2 CS Option
55	IS62WV25616EALL-55BLI	mini BGA (6mm x 8mm), Lead-free

### AUTOMOTIVE RANGE (A3): -40°C TO +125°C

*\*PLEASE CONTACT ISSI MARKETING*

### IS62WV25616EBLL (2.2V - 3.6V)

Industrial Range: -40°C to +85°C

Speed (ns)	Order Part No.	Package
45	IS62WV25616EBLL-45TI	TSOP (Type II)
	IS62WV25616EBLL-45TLI	TSOP (Type II), Lead-free
	IS62WV25616EBLL-45BI	mini BGA (6mm x 8mm)
	IS62WV25616EBLL-45BLI	mini BGA (6mm x 8mm), Lead-free
	IS62WV25616EBLL-45B2I	mini BGA (6mm x 8mm), 2 CS Option
	IS62WV25616EBLL-45B2LI	mini BGA (6mm x 8mm), 2 CS Option, Lead-free
55	IS62WV25616EBLL-55TI	TSOP (Type II)
	IS62WV25616EBLL-55TLI	TSOP (Type II), Lead-free
	IS62WV25616EBLL-55BI	mini BGA (6mm x 8mm)
	IS62WV25616EBLL-55BLI	mini BGA (6mm x 8mm), Lead-free
	IS62WV25616EBLL-55B2I	mini BGA (6mm x 8mm), 2 CS Option
	IS62WV25616EBLL-55B2LI	mini BGA (6mm x 8mm), 2 CS Option, Lead-free

# IS62WV25616EALL/EBLL/ECLL IS65WV25616EBLL/ECLL



## Automotive Range (A1): -40°C to +85°C

Speed (ns)	Order Part No.	Package
45	IS65WV25616EBLL-45CTLA1	TSOP (Type II), Lead-free, Copper Lead-frame
45	IS65WV25616EBLL-45BA1	mini BGA (6mm x 8mm)
45	IS65WV25616EBLL-45BLA1	mini BGA (6mm x 8mm), Lead-free

## Automotive Range (A3): -40°C to +125°C

Speed (ns)	Order Part No.	Package
55	IS65WV25616EBLL-55CTLA3	TSOP (Type II), Lead-free, Copper Lead-frame
55	IS65WV25616EBLL-55BA3	mini BGA (6mm x 8mm)
55	IS65WV25616EBLL-55BLA3	mini BGA (6mm x 8mm), Lead-free

## IS62WV25616ECLL (3.3V +/-5%)

### Industrial Range: -40°C to +85°C

Speed (ns)	Order Part No.	Package
35	IS62WV25616ECLL-35TI	TSOP (Type II)
35	IS62WV25616ECLL-35TLI	TSOP (Type II), Lead-free
35	IS62WV25616ECLL-35BI	mini BGA (6mm x 8mm)
35	IS62WV25616ECLL-35BLI	mini BGA (6mm x 8mm), Lead-free
35	IS62WV25616ECLL-35B2I	mini BGA (6mm x 8mm), 2 CS Option
35	IS62WV25616ECLL-35B2LI	mini BGA (6mm x 8mm), 2 CS Option, Lead-free

## Automotive Range (A3): -40°C to +125°C

Speed (ns)	Order Part No.	Package
45	IS65WV25616ECLL-45CTLA3	TSOP (Type II), Lead-free, Copper Lead-frame
45	IS65WV25616ECLL-45BA3	mini BGA (6mm x 8mm)
45	IS65WV25616ECLL-45BLA3	mini BGA (6mm x 8mm), Lead-free

PACKAGE INFORMATION

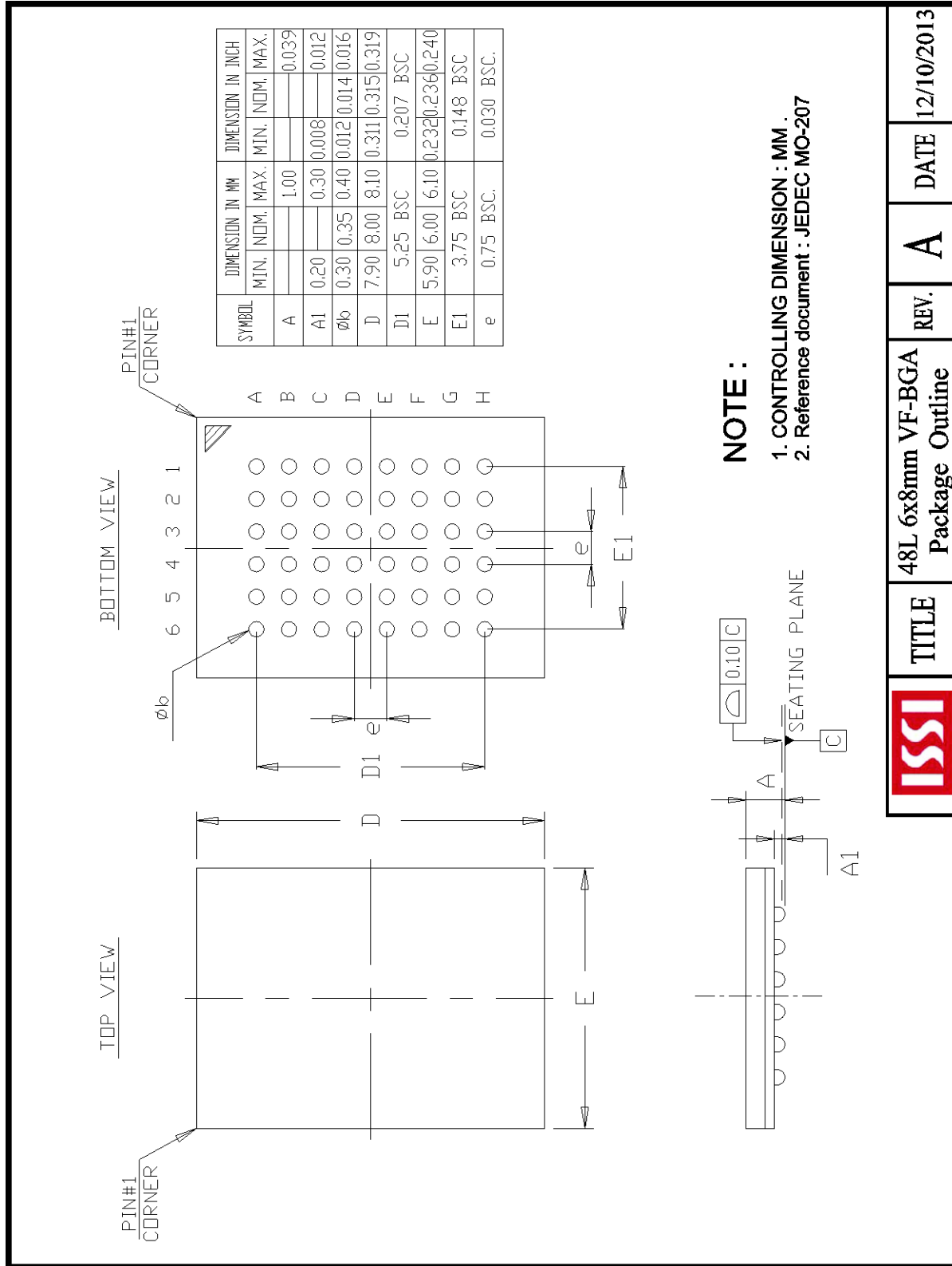



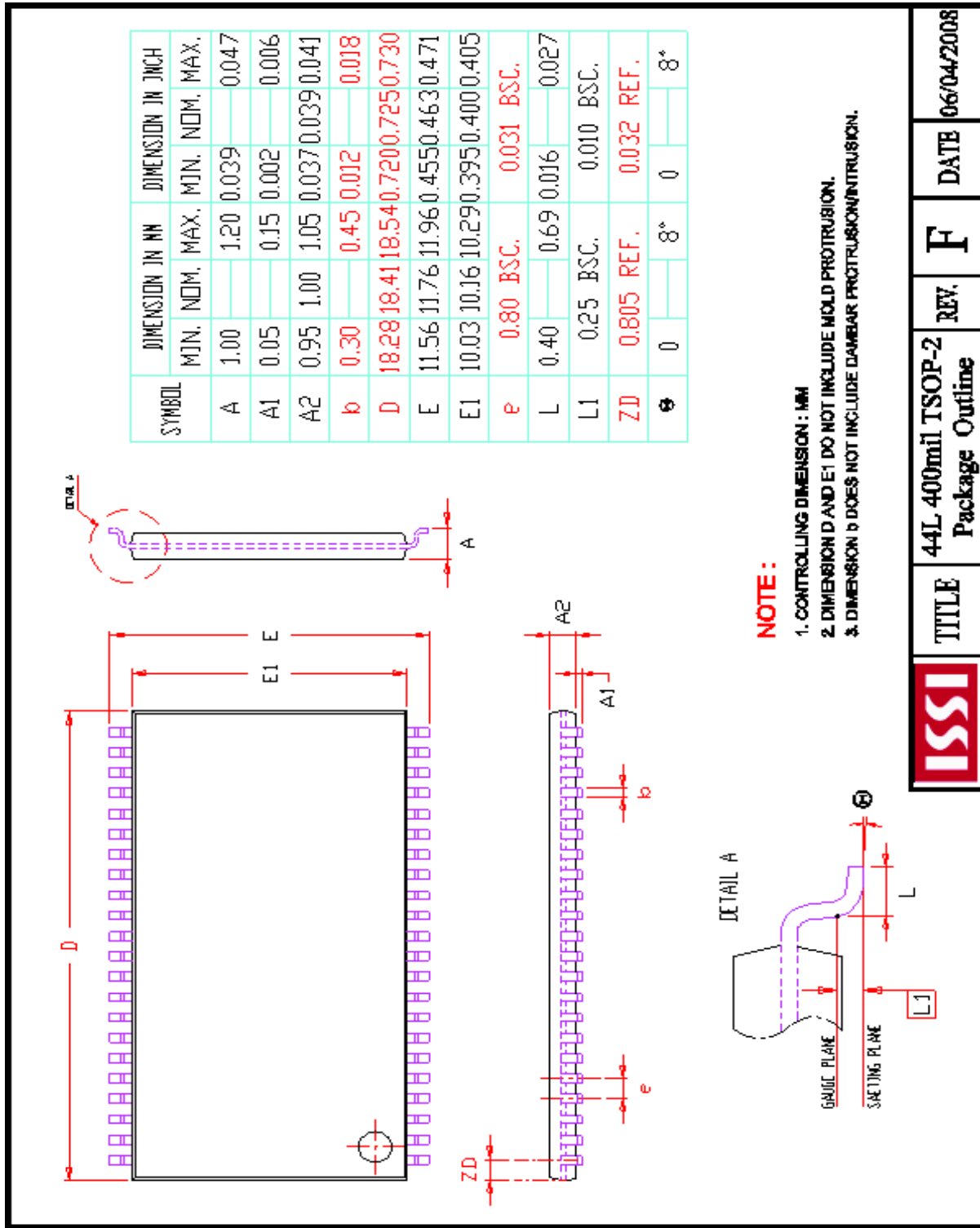

	TITLE	REV.	DATE
	44L 400mil TSOP-2 Package Outline	F	06/04/2008