

TABLE OF CONTENTS

Features	1	Absolute Maximum Ratings.....	5
Applications	1	ESD Caution.....	5
General Description	1	Pin Configuration and Function Descriptions.....	6
Functional Block Diagrams	1	Terminology	7
Product Highlights	1	Typical Performance Characteristics	8
Revision History	2	Test Circuits.....	10
Specifications.....	3	Outline Dimensions	12
Dual Supply	3	Ordering Guide.....	12
Single Supply.....	4		

REVISION HISTORY

11/09—Rev. A to Rev. B

Changes to Table 5.....	5
Changes to Ordering Guide	12

6/07—Rev. 0 to Rev. A

Change to On Resistance Flatness, $R_{\text{FLAT(ON)}}$ Specification (Table 1).....	3
Change to On Resistance Flatness, $R_{\text{FLAT(ON)}}$ Specification (Table 2).....	4
Added Table 6.....	6
Changes to Terminology Section.....	7
Changes to Figure 13	9
Updated Outline Dimensions	12
Changes to Ordering Guide	12

11/01—Revision 0: Initial Version

SPECIFICATIONS

DUAL SUPPLY¹

$V_{DD} = +5\text{ V} \pm 10\%$, $V_{SS} = -5\text{ V} \pm 10\%$, GND = 0 V, unless otherwise noted.

Table 1.

Parameter	+25°C	-40°C to +85°C	Unit	Test Conditions/Comments
ANALOG SWITCH				
Analog Signal Range		V_{SS} to V_{DD}	V	$V_{DD} = +4.5\text{ V}$, $V_{SS} = -4.5\text{ V}$
On Resistance, R_{ON}	4		Ω typ	$V_S = \pm 4.5\text{ V}$, $I_S = -10\text{ mA}$, see Figure 16
	5.5	7	Ω max	
On Resistance Match Between Channels, ΔR_{ON}	0.25		Ω typ	$V_S = \pm 4.5\text{ V}$, $I_S = -10\text{ mA}$
	0.35	0.4	Ω max	
On Resistance Flatness, $R_{FLAT(ON)}$	0.9	0.9	Ω typ	$V_S = \pm 3.3\text{ V}$, $I_S = -10\text{ mA}$
		1.5	Ω max	
LEAKAGE CURRENTS				
Source Off Leakage, I_S (Off)	± 0.01		nA typ	$V_{DD} = +5.5\text{ V}$, $V_{SS} = -5.5\text{ V}$
	± 0.25	± 1	nA max	$V_S = \pm 4.5\text{ V}$, $V_D = \mp 4.5\text{ V}$, see Figure 17
Drain Off Leakage, I_D (Off)	± 0.01		nA typ	$V_S = \pm 4.5\text{ V}$, $V_D = \mp 4.5\text{ V}$, see Figure 17
	± 0.25	± 1	nA max	
Channel On Leakage, I_D , I_S (On)	± 0.01		nA typ	$V_S = V_D = \pm 4.5\text{ V}$, see Figure 18
	± 0.25	± 1	nA max	
DIGITAL INPUTS				
Input High Voltage, V_{INH}		2.4	V min	
Input Low Voltage, V_{INL}		0.8	V max	
Input Current, I_{INL} or I_{INH}	0.005		μA typ	$V_{IN} = V_{INL}$ or V_{INH}
		± 0.1	μA max	
Digital Input Capacitance, C_{IN}	2		pF typ	
DYNAMIC CHARACTERISTICS²				
t_{ON}	75		ns typ	$R_L = 300\ \Omega$, $C_L = 35\text{ pF}$; $V_S = 3.3\text{ V}$, see Figure 19
	120	155	ns max	
t_{OFF}	45		ns typ	$R_L = 300\ \Omega$, $C_L = 35\text{ pF}$; $V_S = 3.3\text{ V}$, see Figure 19
	70	85	ns max	
Break-Before-Make Time Delay, t_{BBM} (ADG623 Only)	30		ns typ	$R_L = 300\ \Omega$, $C_L = 35\text{ pF}$; $V_{S1} = V_{S2} = 3.3\text{ V}$
		10	ns min	See Figure 20
Charge Injection	110		pC typ	$V_S = 0\text{ V}$, $R_S = 0\ \Omega$, $C_L = 1\text{ nF}$, see Figure 21
Off Isolation	-65		dB typ	$R_L = 50\ \Omega$, $C_L = 5\text{ pF}$, $f = 1\text{ MHz}$, see Figure 22
Channel-to-Channel Crosstalk	-90		dB typ	$R_L = 50\ \Omega$, $C_L = 5\text{ pF}$, $f = 1\text{ MHz}$, see Figure 23
Bandwidth -3 dB	230		MHz typ	$R_L = 50\ \Omega$, $C_L = 5\text{ pF}$, see Figure 24
C_S (Off)	20		pF typ	$f = 1\text{ MHz}$
C_D (Off)	20		pF typ	$f = 1\text{ MHz}$
C_D , C_S (On)	70		pF typ	$f = 1\text{ MHz}$
POWER REQUIREMENTS				
I_{DD}	0.001		μA typ	$V_{DD} = 5.5\text{ V}$, $V_{SS} = -5.5\text{ V}$
		1.0	μA max	Digital inputs = 0 V or 5.5 V
I_{SS}	0.001		μA typ	Digital inputs = 0 V or 5.5 V
		1.0	μA max	

¹ Temperature range is as follows: B version, -40°C to +85°C.

² Guaranteed by design; not subject to production test.

ADG622/ADG623

SINGLE SUPPLY¹

$V_{DD} = 5\text{ V} \pm 10\%$, $V_{SS} = 0\text{ V}$, $GND = 0\text{ V}$, unless otherwise noted.

Table 2.

Parameter	+25°C	-40°C to +85°C	Unit	Test Conditions/Comments
ANALOG SWITCH				
Analog Signal Range		0 to V_{DD}	V	$V_{DD} = 4.5\text{ V}$, $V_{SS} = 0\text{ V}$
On Resistance, R_{ON}	7		Ω typ	$V_S = 0\text{ V}$ to 4.5 V , $I_S = -10\text{ mA}$, see Figure 16
	10	12.5	Ω max	
On Resistance Match Between Channels, ΔR_{ON}	0.5		Ω typ	$V_S = 0\text{ V}$ to 4.5 V , $I_S = -10\text{ mA}$
	0.75	1	Ω max	
On Resistance Flatness, $R_{FLAT(ON)}$	0.5	0.5	Ω typ	$V_S = 1.5\text{ V}$ to 3.3 V , $I_S = -10\text{ mA}$
		1.2	Ω max	
LEAKAGE CURRENTS				
Source Off Leakage I_S (Off)	± 0.01		nA typ	$V_{DD} = 5.5\text{ V}$ $V_S = 1\text{ V}/4.5\text{ V}$, $V_D = 4.5\text{ V}/1\text{ V}$, see Figure 17
	± 0.25	± 1	nA max	
Drain Off Leakage I_D (Off)	± 0.01		nA typ	$V_S = 1\text{ V}/4.5\text{ V}$, $V_D = 4.5\text{ V}/1\text{ V}$, see Figure 17
	± 0.25	± 1	nA max	
Channel On Leakage, I_D , I_S (On)	± 0.01		nA typ	$V_S = V_D = 1\text{ V}/4.5\text{ V}$, see Figure 18
	± 0.25	± 1	nA max	
DIGITAL INPUTS				
Input High Voltage, V_{INH}		2.4	V min	
Input Low Voltage, V_{INL}		0.8	V max	
Input Current, I_{INL} or I_{INH}	0.005		μA typ	$V_{IN} = V_{INL}$ or V_{INH}
		± 0.1	μA max	
Digital Input Capacitance, C_{IN}	2		pF typ	
DYNAMIC CHARACTERISTICS²				
t_{ON}	120		ns typ	$R_L = 300\ \Omega$, $C_L = 35\text{ pF}$, $V_S = 3.3\text{ V}$, see Figure 19
	210	260	ns max	
t_{OFF}	50		ns typ	$R_L = 300\ \Omega$, $C_L = 35\text{ pF}$, $V_S = 3.3\text{ V}$, see Figure 19
	75	100	ns max	
Break-Before-Make Time Delay, t_{BBM} (ADG623 Only)	70		ns typ	$R_L = 300\ \Omega$, $C_L = 35\text{ pF}$, $V_{S1} = V_{S2} = 3.3\text{ V}$
		10	ns min	See Figure 20
Charge Injection	6		pC typ	$V_S = 0\text{ V}$; $R_S = 0\ \Omega$, $C_L = 1\text{ nF}$, see Figure 21
Off Isolation	-65		dB typ	$R_L = 50\ \Omega$, $C_L = 5\text{ pF}$, $f = 1\text{ MHz}$, see Figure 22
Channel-to-Channel Crosstalk	-90		dB typ	$R_L = 50\ \Omega$, $C_L = 5\text{ pF}$, $f = 1\text{ MHz}$, see Figure 23
Bandwidth -3 dB	230		MHz typ	$R_L = 50\ \Omega$, $C_L = 5\text{ pF}$, see Figure 24
C_S (Off)	20		pF typ	$f = 1\text{ MHz}$
C_D (Off)	20		pF typ	$f = 1\text{ MHz}$
C_D , C_S (On)	70		pF typ	$f = 1\text{ MHz}$
POWER REQUIREMENTS				
I_{DD}	0.001		μA typ	$V_{DD} = 5.5\text{ V}$ Digital Inputs = 0 V or 5.5 V
		1.0	μA max	

¹ Temperature range is as follows: B Version, -40°C to +85°C.

² Guaranteed by design; not subject to production test.

ABSOLUTE MAXIMUM RATINGS

$T_A = 25^\circ\text{C}$, unless otherwise noted.

Table 3.

Parameter	Rating
V_{DD} to V_{SS}	13 V
V_{DD} to GND	-0.3 V to +6.5 V
V_{SS} to GND	+0.3 V to -6.5 V
Analog Inputs ¹	$V_{SS} - 0.3\text{ V}$ to $V_{DD} + 0.3\text{ V}$
Digital Inputs ¹	-0.3 V to $V_{DD} + 0.3\text{ V}$ or 30 mA, whichever occurs first
Peak Current, S or D	100 mA (pulsed at 1 ms, 10% duty cycle maximum)
Continuous Current, S or D	50 mA
Operating Temperature Range Industrial (B Version)	-40°C to +85°C
Storage Temperature Range	-65°C to +150°C
Junction Temperature	150°C
MSOP Package	
θ_{JA} Thermal Impedance	206°C/W
θ_{JC} Thermal Impedance	44°C/W
Lead Soldering	
Lead Temperature, Soldering (10 sec)	300°C
IR Reflow, Peak Temperature	220°C
Pb-Free Soldering	
Reflow, Peak Temperature	260(+0/-5)°C
Time at Peak Temperature	20 sec to 40 sec

¹ Overvoltages at INx, S, or D must be clamped by internal diodes. Currents should be limited to the maximum ratings given.

Stresses above those listed under Absolute Maximum Ratings may cause permanent damage to the device. This is a stress rating only; functional operation of the device at these or any other conditions above those listed in the operational sections of this specification is not implied. Exposure to absolute maximum rating conditions for extended periods may affect device reliability.

Only one absolute maximum rating may be applied at any one time.

Table 4. ADG621/ADG622 Truth Table

ADG621 INx	ADG622 INx	Switch Sx Condition
0	1	Off
1	0	On

Table 5. ADG623 Truth Table

IN1	IN2	Switch S1	Switch S2
0	0	Off	On
0	1	Off	Off
1	0	On	On
1	1	On	Off

ESD CAUTION



ESD (electrostatic discharge) sensitive device. Charged devices and circuit boards can discharge without detection. Although this product features patented or proprietary protection circuitry, damage may occur on devices subjected to high energy ESD. Therefore, proper ESD precautions should be taken to avoid performance degradation or loss of functionality.

ADG622/ADG623

PIN CONFIGURATION AND FUNCTION DESCRIPTIONS

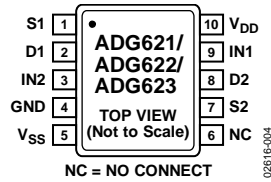

Figure 4. 10-Lead MSOP (RM-10)

Table 6. Pin Function Descriptions

Pin No.	Mnemonic	Description
1, 7	S1, S2	Source Terminal. May be an input or an output.
2, 8	D1, D2	Drain Terminal. May be an input or an output.
3, 9	IN2, IN1	Control Input.
4	GND	Ground (0V) Reference.
5	V _{SS}	Most Negative Power Supply in a Dual-Supply Application. In single-supply applications, this should be tied to ground at the device.
6	NC	No Connect.
10	V _{DD}	Most Positive Power Supply Potential.

TERMINOLOGY

I_{DD}

Positive supply current.

I_{SS}

Negative supply current

$V_D (V_S)$

Analog voltage on Terminal D and Terminal S.

R_{ON}

Ohmic resistance between Terminal D and Terminal S.

$R_{FLAT (ON)}$

On resistance flatness is defined as the difference between the maximum and minimum value of on resistance as measured over the specified analog signal range.

ΔR_{ON}

On resistance match between any two channels.

$I_S (Off)$

Source leakage current with the switch off.

$I_D (Off)$

Drain leakage current with the switch off.

$I_D, I_S (On)$

Channel leakage current with the switch on.

V_{INL}

Maximum input voltage for Logic 0.

V_{INH}

Minimum input voltage for Logic 1.

$I_{INL} (I_{INH})$

Input current of the digital input.

$C_S (Off)$

Off switch source capacitance. Measured with reference to ground.

$C_D (Off)$

Off switch drain capacitance. Measured with reference to ground.

$C_D, C_S (On)$

On switch capacitance. Measured with reference to ground.

C_{IN}

Digital input capacitance.

t_{ON}

Delay time between the 50% and the 90% points of the digital input and switch on condition.

t_{OFF}

Delay time between the 50% and the 90% points of the digital input and switch off condition.

t_{BBM}

On or off time measured between the 90% points of both switches when switching from one address state to another.

Charge Injection

A measure of the glitch impulse transferred from the digital input to the analog output during on-off switching.

Off Isolation

A measure of an unwanted signal coupling through an off switch.

Crosstalk

A measure of an unwanted signal that is coupled through from one channel to another as a result of parasitic capacitance.

-3 dB Bandwidth

The frequency at which the output is attenuated by 3 dB.

On Response

The frequency response of the on switch.

Insertion Loss

The attenuation between the input and output ports of the switch when the switch is in the on condition and is due to the on resistance of the switch.

TYPICAL PERFORMANCE CHARACTERISTICS

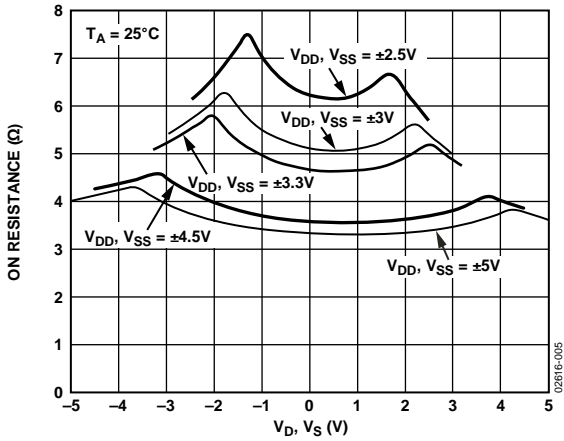

Figure 5. On Resistance vs. V_D , V_S (Dual Supply)

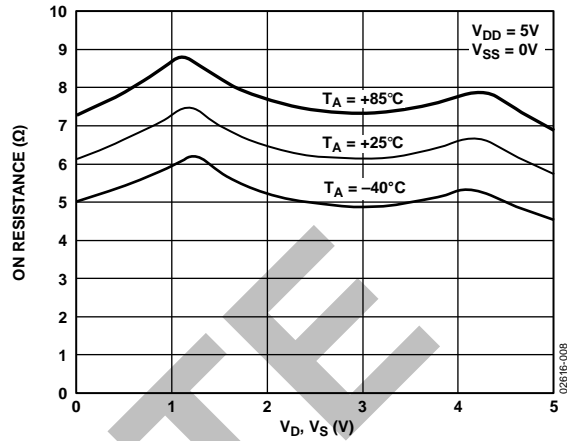

Figure 8. On Resistance vs. V_D , V_S for Different Temperature (Single Supply)

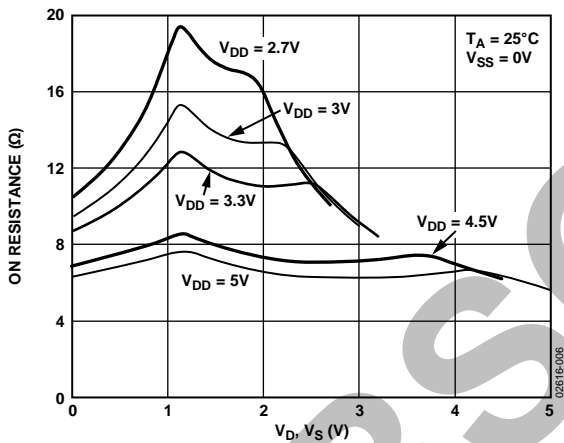

Figure 6. On Resistance vs. V_D , V_S (Single Supply)

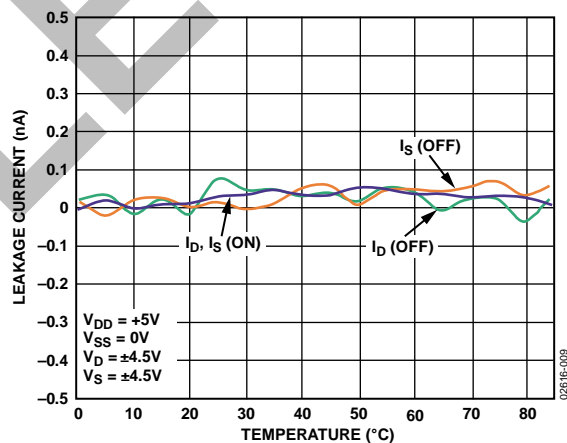

Figure 9. Leakage Current vs. Temperature (Dual Supply)

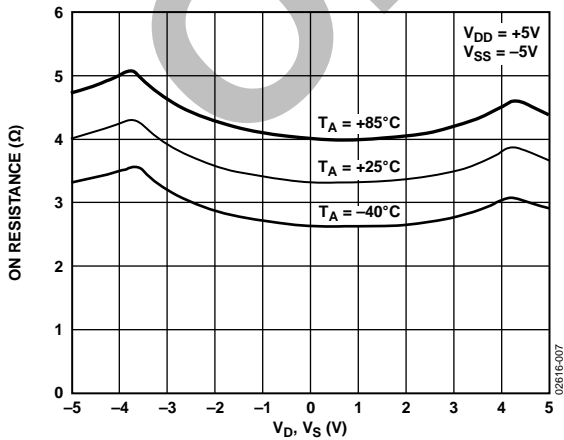

Figure 7. On Resistance vs. V_D , V_S for Different Temperatures (Dual Supply)

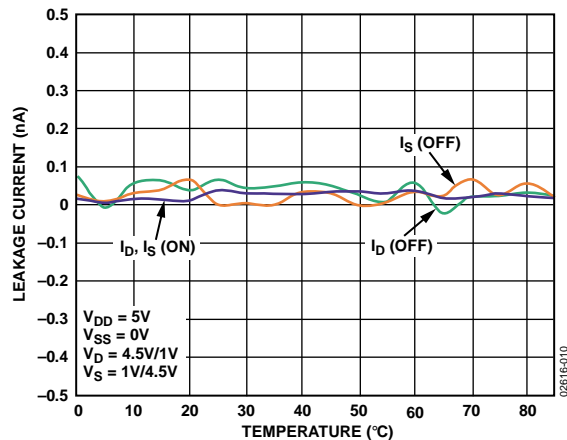

Figure 10. Leakage Current vs. Temperature (Single Supply)

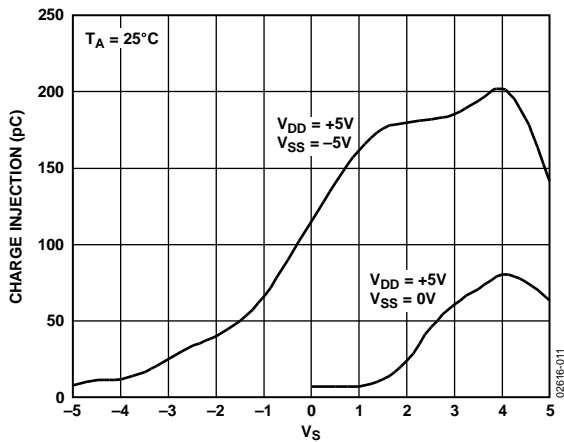

Figure 11. Charge Injection vs. Source Voltage

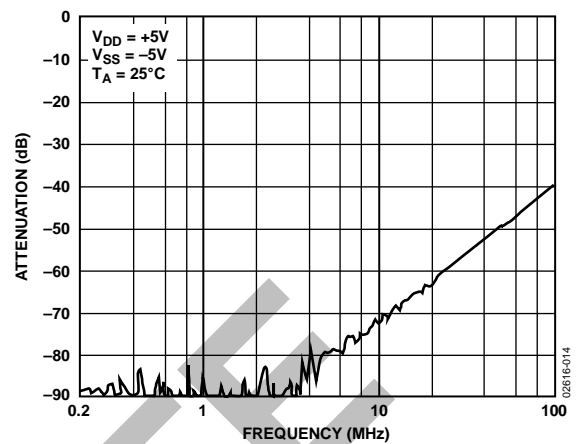

Figure 14. Crosstalk vs. Frequency

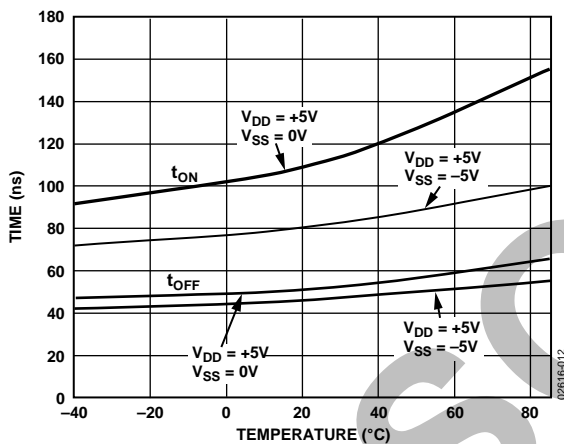

Figure 12. t_{ON}/t_{OFF} Times vs. Temperature

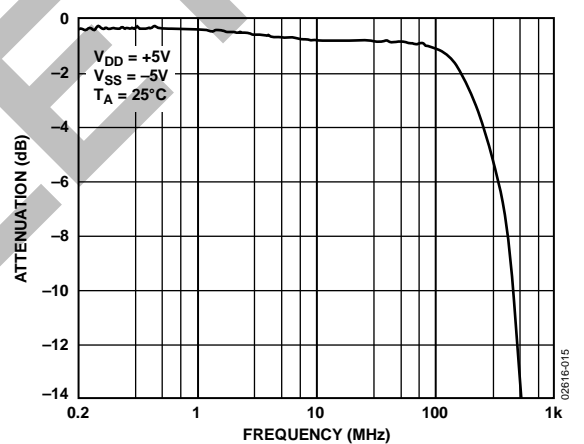

Figure 15. On Response vs. Frequency

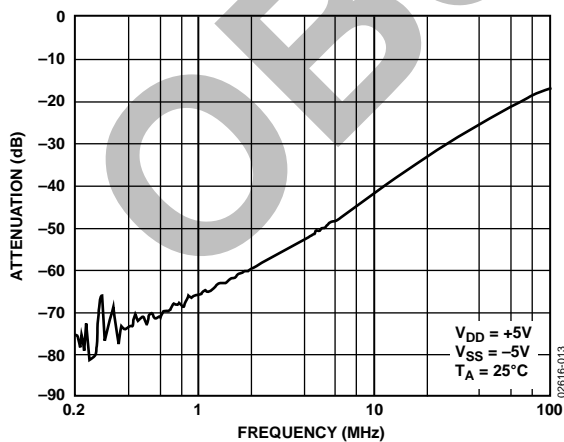

Figure 13. Off Isolation vs. Frequency

TEST CIRCUITS

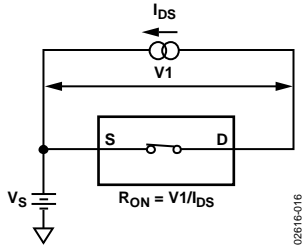

Figure 16. On Resistance

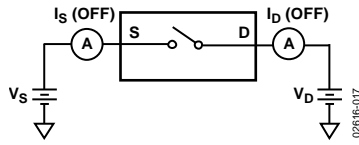

Figure 17. Off Leakage

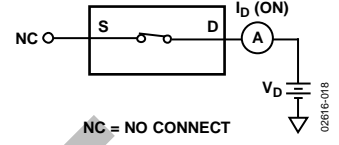

Figure 18. On Leakage
NC = NO CONNECT

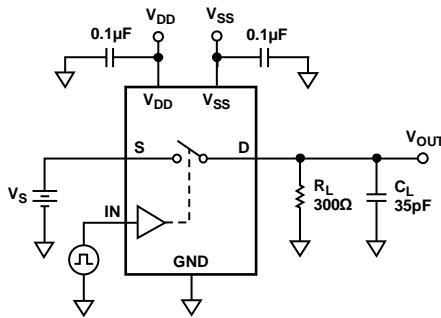

Figure 19. Switching Times (t_{ON} , t_{OFF})

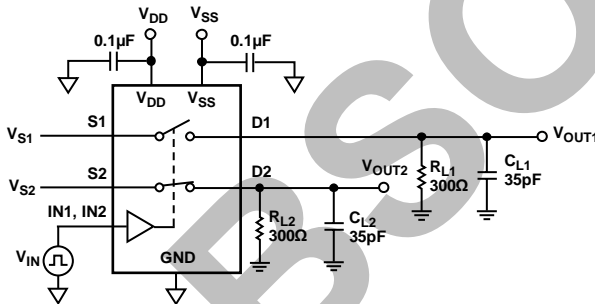
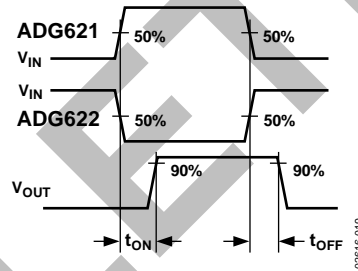

Figure 20. Break-Before-Make Time Delay, t_{BBM} (ADG623 Only)

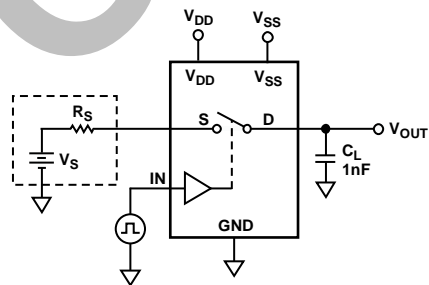
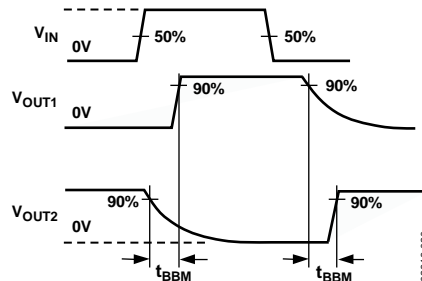
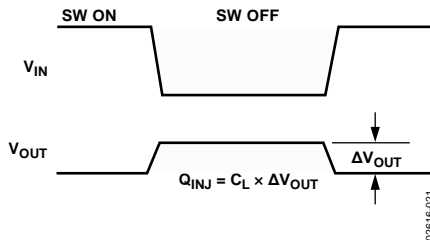

Figure 21. Charge Injection



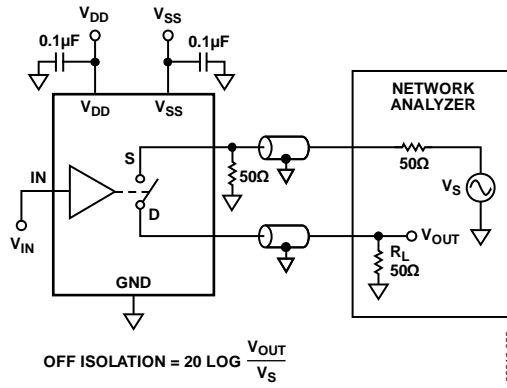

Figure 22. Off Isolation

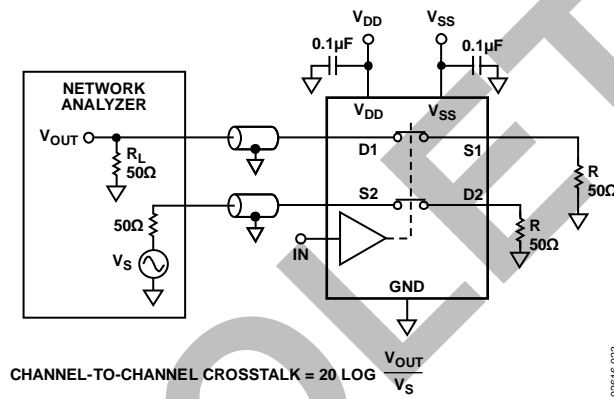

Figure 23. Channel-to-Channel Crosstalk

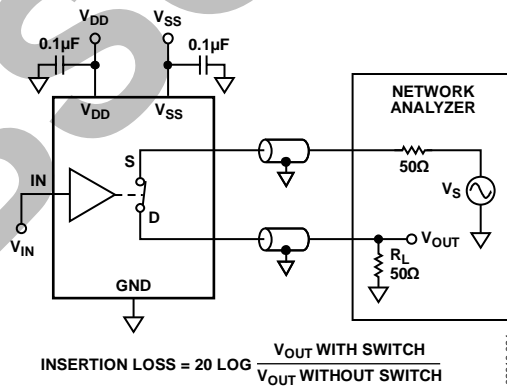
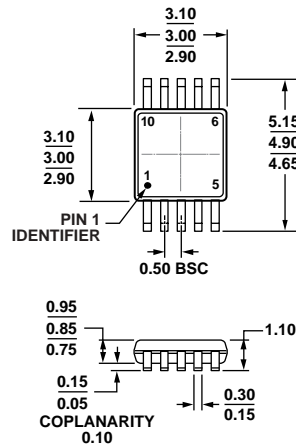

Figure 24. Bandwidth

OUTLINE DIMENSIONS



COMPLIANT TO JEDEC STANDARDS MO-187-BA

Figure 25. 10-Lead Mini Small Outline Package [MSOP] (RM-10)

Dimensions shown in millimeters

ORDERING GUIDE

Model	Temperature Range	Package Description	Package Option	Branding
ADG621BRM	-40°C to +85°C	10-Lead Mini Small Outline Package [MSOP]	RM-10	SXB
ADG621BRM-REEL7	-40°C to +85°C	10-Lead Mini Small Outline Package [MSOP]	RM-10	SXB
ADG621BRMZ ¹	-40°C to +85°C	10-Lead Mini Small Outline Package [MSOP]	RM-10	SXB#
ADG621BRMZ-REEL ¹	-40°C to +85°C	10-Lead Mini Small Outline Package [MSOP]	RM-10	SXB#
ADG622BRM	-40°C to +85°C	10-Lead Mini Small Outline Package [MSOP]	RM-10	SYB
ADG622BRM-REEL	-40°C to +85°C	10-Lead Mini Small Outline Package [MSOP]	RM-10	SYB
ADG622BRM-REEL7	-40°C to +85°C	10-Lead Mini Small Outline Package [MSOP]	RM-10	SYB
ADG622BRMZ ¹	-40°C to +85°C	10-Lead Mini Small Outline Package [MSOP]	RM-10	S12
ADG622BRMZ-REEL ¹	-40°C to +85°C	10-Lead Mini Small Outline Package [MSOP]	RM-10	S12
ADG622BRMZ-REEL7 ¹	-40°C to +85°C	10-Lead Mini Small Outline Package [MSOP]	RM-10	S12
ADG623BRM	-40°C to +85°C	10-Lead Mini Small Outline Package [MSOP]	RM-10	SZB
ADG623BRM-REEL	-40°C to +85°C	10-Lead Mini Small Outline Package [MSOP]	RM-10	SZB
ADG623BRM-REEL7	-40°C to +85°C	10-Lead Mini Small Outline Package [MSOP]	RM-10	SZB
ADG623BRMZ ¹	-40°C to +85°C	10-Lead Mini Small Outline Package [MSOP]	RM-10	SZB#
ADG623BRMZ-REEL ¹	-40°C to +85°C	10-Lead Mini Small Outline Package [MSOP]	RM-10	SZB#
ADG623BRMZ-REEL7 ¹	-40°C to +85°C	10-Lead Mini Small Outline Package [MSOP]	RM-10	SZB#

¹ Z= RoHS Compliant Part, # denotes RoHS compliant product and may be top or bottom marked.