

AD7747* PRODUCT PAGE QUICK LINKS

Last Content Update: 02/23/2017

COMPARABLE PARTS

View a parametric search of comparable parts.

EVALUATION KITS

- AD7747 Evaluation Kit

DOCUMENTATION

Application Notes

- AN-1301: Using CDCs to Control Motion for Sample Aspiration

Data Sheet

- AD7747: 24-Bit Capacitance-to-Digital Converter with Temperature Sensor Data Sheet

Product Highlight

- Leading Inside Advertorials: Providing an Edge in Capacitive Sensor Applications

SOFTWARE AND SYSTEMS REQUIREMENTS

- AD7746 - Microcontroller No-OS Driver
- AD7746 IIO Capacitance to Digital Converter Linux Driver

REFERENCE MATERIALS

Technical Articles

- MS-2210: Designing Power Supplies for High Speed ADC

DESIGN RESOURCES

- AD7747 Material Declaration
- PCN-PDN Information
- Quality And Reliability
- Symbols and Footprints

DISCUSSIONS

View all AD7747 EngineerZone Discussions.

SAMPLE AND BUY

Visit the product page to see pricing options.

TECHNICAL SUPPORT

Submit a technical question or find your regional support number.

DOCUMENT FEEDBACK

Submit feedback for this data sheet.

This page is dynamically generated by Analog Devices, Inc., and inserted into this data sheet. A dynamic change to the content on this page will not trigger a change to either the revision number or the content of the product data sheet. This dynamic page may be frequently modified.

TABLE OF CONTENTS

Features	1	Cap DAC A Register	19
Applications.....	1	Cap DAC B Register.....	19
General Description	1	Cap Offset Calibration Register	20
Functional Block Diagram	1	Cap Gain Calibration Register.....	20
Revision History	2	Volt Gain Calibration Register	20
Specifications.....	3	Circuit Description.....	21
Timing Specifications	5	Overview	21
Absolute Maximum Ratings.....	6	Capacitance-to-Digital Converter.....	21
ESD Caution.....	6	Active AC Shield Concept.....	21
Pin Configuration and Function Descriptions.....	7	CAPDAC	21
Typical Performance Characteristics	8	Single-Ended Capacitive Configuration	22
Output Noise and Resolution Specifications	11	Differential Capacitive Configuration.....	22
Serial Interface	12	Parasitic Capacitance	23
Read Operation.....	12	Parasitic Resistance	23
Write Operation.....	12	Parasitic Serial Resistance	23
AD7747 Reset.....	13	Capacitive Gain Calibration	23
General Call.....	13	Capacitive System Offset Calibration	24
Register Descriptions	14	Internal Temperature Sensor	24
Status Register	15	External Temperature Sensor	24
Cap Data Register	15	Voltage Input.....	25
VT Data Register	15	V _{DD} Monitor	25
Cap Setup Register	16	Typical Application Diagram.....	26
VT Setup Register.....	16	Outline Dimensions	27
EXC Setup Register	17	Ordering Guide	27
Configuration Register	18		

REVISION HISTORY

1/07—Revision 0: Initial Version

SPECIFICATIONS

$V_{DD} = 2.7\text{ V to }3.6\text{ V or }4.75\text{ V to }5.25\text{ V}$; $GND = 0\text{ V}$; $EXC = \pm V_{DD} \times 3/8$; $-40^{\circ}\text{C to }+125^{\circ}\text{C}$, unless otherwise noted.

Table 1.

Parameter	Min	Typ	Max	Unit	Test Conditions/Comments
CAPACITIVE INPUT					
Conversion Input Range		± 8.192		pF ¹	Factory calibrated
Integral Nonlinearity (INL) ²			± 0.01	% of FSR ¹	
No Missing Codes ²	24			Bit	Conversion time $\geq 124\text{ ms}$
Resolution, p-p		16.5		Bit	Conversion time 124 ms, see Table 5
Resolution Effective		19.1		Bit	Conversion time 124 ms, see Table 5
Output Noise, rms		11.0		aF/ $\sqrt{\text{Hz}}$	Conversion time 124 ms, see Table 5
Absolute Error ³			± 10	fF ¹	25°C, $V_{DD} = 5\text{ V}$, after offset calibration
Offset Error ^{4,5}			32	aF ¹	After system offset calibration, excluding effect of noise ⁴
System Offset Calibration Range ⁵			± 1	pF	
Offset Deviation over Temperature ²		0.4		fF	See Figure 6
Gain Error ⁶		0.02	0.11	% of FS ¹	25°C, $V_{DD} = 5\text{ V}$
Gain Drift vs. Temperature ²	-23	-26	-29	ppm of FS/ $^{\circ}\text{C}$	
Power Supply Rejection ²		0.5	4	fF/V	
Normal Mode Rejection ⁵		72		dB	50 Hz $\pm 1\%$, conversion time 124 ms
		60		dB	60 Hz $\pm 1\%$, conversion time 124 ms
CAPDAC					
Full Range	17	21		pF	6-bit CAPDAC
Differential Nonlinearity (DNL)		0.3		LSB	See Figure 16
Drift vs. Temperature ²		26		ppm of FS/ $^{\circ}\text{C}$	
EXCITATION					
Frequency		16		kHz	
AC Voltage Across Capacitance		$\pm V_{DD} \times 3/8$		V	To be configured via digital interface
Average DC Voltage Across Capacitance		$V_{DD}/2$		V	
TEMPERATURE SENSOR⁷					
Resolution		0.1		$^{\circ}\text{C}$	V_{REF} internal
Error ²		± 0.5	± 2	$^{\circ}\text{C}$	Internal temperature sensor
		± 2		$^{\circ}\text{C}$	External sensing diode ⁸
VOLTAGE INPUT⁷					
Differential VIN Voltage Range		$\pm V_{REF}$		V	V_{REF} internal or $V_{REF} = 2.5\text{ V}$
Absolute VIN Voltage ²	$GND - 0.03$		$V_{DD} + 0.03$	V	
Integral Nonlinearity (INL)		± 3	± 15	ppm of FS	
No Missing Codes ²	24			Bit	Conversion time = 122.1 ms
Resolution, p-p		16		Bits	Conversion time = 62 ms, see Table 6 and Table 7
Output Noise		3		$\mu\text{V rms}$	Conversion time = 62 ms, see Table 6 and Table 7
Offset Error		± 3		μV	
Offset Drift vs. Temperature		15		nV/ $^{\circ}\text{C}$	
Full-Scale Error ^{2,9}		0.025	0.1	% of FS	
Full-Scale Drift vs. Temperature		5		ppm of FS/ $^{\circ}\text{C}$	Internal reference
		0.5		ppm of FS/ $^{\circ}\text{C}$	External reference
Average VIN Input Current		300		nA/V	
Analog VIN Input Current Drift		± 50		pA/V/ $^{\circ}\text{C}$	
Power Supply Rejection		80		dB	Internal reference, $V_{IN} = V_{REF}/2$
		90		dB	External reference, $V_{IN} = V_{REF}/2$

AD7747

Parameter	Min	Typ	Max	Unit	Test Conditions/Comments
Normal Mode Rejection ⁵		75		dB	50 Hz ± 1%, conversion time = 122.1 ms
Common-Mode Rejection ²		50		dB	60 Hz ± 1%, conversion time = 122.1 ms
		95		dB	V _{IN} = 1 V
INTERNAL VOLTAGE REFERENCE					
Voltage	1.169	1.17	1.171	V	T _A = 25°C
Drift vs. Temperature		5		ppm/°C	
EXTERNAL VOLTAGE REFERENCE INPUT					
Differential REF _{IN} Voltage ²	0.1	2.5	V _{DD}	V	
Absolute REF _{IN} Voltage ²	GND – 0.03		V _{DD} + 0.03	V	
Average REF _{IN} Input Current		400		nA/V	
Average REF _{IN} Input Current Drift		±50		pA/V/°C	
Common-Mode Rejection		80		dB	
SERIAL INTERFACE LOGIC INPUTS (SCL, SDA)					
V _{IH} Input High Voltage	2.1			V	
V _{IL} Input Low Voltage			0.8	V	
Hysteresis		150		mV	
Input Leakage Current (SCL)		±0.1	±1	µA	
OPEN-DRAIN OUTPUT (SDA)					
V _{OL} Output Low Voltage			0.4	V	I _{SINK} = –6.0 mA
I _{OH} Output High Leakage Current		0.1	1	µA	V _{OUT} = V _{DD}
LOGIC OUTPUT (RDY)					
V _{OL} Output Low Voltage			0.4	V	I _{SINK} = 1.6 mA, V _{DD} = 5 V
V _{OH} Output High Voltage	4.0			V	I _{SOURCE} = 200 µA, V _{DD} = 5 V
V _{OL} Output Low Voltage			0.4	V	I _{SINK} = 100 µA, V _{DD} = 3 V
V _{OH} Output High Voltage	V _{DD} – 0.6			V	I _{SOURCE} = 100 µA, V _{DD} = 3 V
POWER REQUIREMENTS					
V _{DD-to-GND} Voltage	4.75		5.25	V	V _{DD} = 5 V, nominal
	2.7		3.6	V	V _{DD} = 3.3 V, nominal
I _{DD} Current			850	µA	Digital inputs equal to V _{DD} or GND
		750		µA	V _{DD} = 5 V
		700		µA	V _{DD} = 3.3 V
I _{DD} Current Power-Down Mode		0.5	2	µA	Digital inputs equal to V _{DD} or GND

¹ Capacitance units: 1 pF = 10⁻¹² F; 1 fF = 10⁻¹⁵ F; 1 aF = 10⁻¹⁸ F. Full scale (FS) = 8.192 pF; full-scale range (FSR) = ±8.192 pF.

² Specification is not production tested, but is supported by characterization data at initial product release.

³ Factory calibrated. The absolute error includes factory gain calibration error, integral nonlinearity error, and offset error after system offset calibration, all at 25°C. At different temperatures, compensation for gain drift over temperature is required.

⁴ The capacitive input offset can be eliminated using a system offset calibration. The accuracy of the system offset calibration is limited by the offset calibration register LSB size (32 aF) or by converter + system p-p noise during the system capacitive offset calibration, whichever is greater. To minimize the effect of the converter + system noise, longer conversion times should be used for system capacitive offset calibration. The system capacitance offset calibration range is ±1 pF; the larger offset can be removed using CAPDACs.

⁵ Specification is not production tested, but guaranteed by design.

⁶ The gain error is factory calibrated at 25°C. At different temperatures, compensation for gain drift over temperature is required.

⁷ The VTCHOP bit in the VT SETUP register must be set to 1 for the specified temperature sensor and voltage input performance.

⁸ Using an external temperature sensing diode 2N3906, with nonideality factor n_r = 1.008, connected as in Figure 37, with total serial resistance <100 Ω.

⁹ Full-scale error applies to both positive and negative full scale.

TIMING SPECIFICATIONS

$V_{DD} = 2.7\text{ V to }3.6\text{ V, or }4.75\text{ V to }5.25\text{ V; GND} = 0\text{ V; Input Logic }0 = 0\text{ V; Input Logic }1 = V_{DD}; -40^{\circ}\text{C to }+125^{\circ}\text{C, unless otherwise noted.}$

Table 2.

Parameter	Min	Typ	Max	Unit	Test Conditions/Comments
SERIAL INTERFACE ^{1, 2}					
SCL Frequency	0		400	kHz	See Figure 2
SCL High Pulse Width, t_{HIGH}	0.6			μs	
SCL Low Pulse Width, t_{LOW}	1.3			μs	
SCL, SDA Rise Time, t_R			0.3	μs	
SCL, SDA Fall Time, t_F			0.3	μs	
Hold Time (Start Condition), $t_{HD;STA}$	0.6			μs	After this period, the first clock is generated
Setup Time (Start Condition), $t_{SU;STA}$	0.6			μs	Relevant for repeated start condition
Data Setup Time, $t_{SU;DAT}$	0.1			μs	
Setup Time (Stop Condition), $t_{SU;STO}$	0.6			μs	
Data Hold Time, $t_{HD;DAT}$ (Master)	0			μs	
Bus-Free Time (Between Stop and Start Condition, t_{BUF})	1.3			μs	

¹ Sample tested during initial release to ensure compliance.

² All input signals are specified with input rise/fall times = 3 ns, measured between the 10% and 90% points. Timing reference points at 50% for inputs and outputs. Output load = 10 pF.

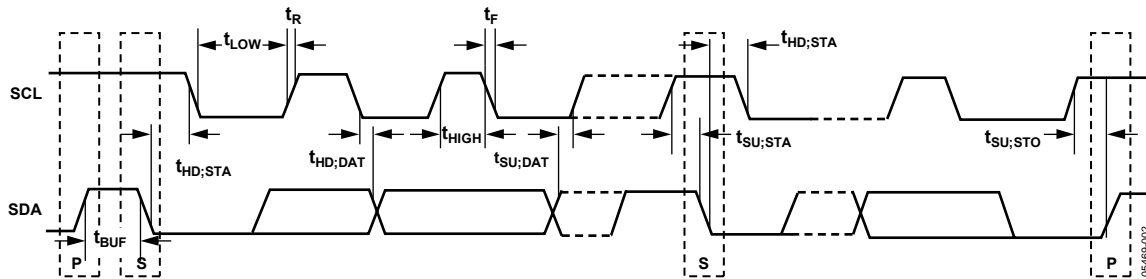

Figure 2. Serial Interface Timing Diagram

ABSOLUTE MAXIMUM RATINGS

$T_A = 25^\circ\text{C}$, unless otherwise noted.

Table 3.

Parameter	Rating
Positive Supply Voltage V_{DD} to GND	$-0.3\text{ V to }+6.5\text{ V}$
Voltage on any Input or Output Pin to GND	$-0.3\text{ V to }V_{DD} + 0.3\text{ V}$
ESD Rating (ESD Association Human Body Model, S5.1)	2000 V
Operating Temperature Range	$-40^\circ\text{C to }+125^\circ\text{C}$
Storage Temperature Range	$-65^\circ\text{C to }+150^\circ\text{C}$
Junction Temperature	150°C
TSSOP Package θ_{JA} (Thermal Impedance-to-Air)	128°C/W
TSSOP Package θ_{JC} (Thermal Impedance-to-Case)	14°C/W
Peak Reflow Soldering Temperature Pb Free (20 sec to 40 sec)	260°C

Stresses above those listed under Absolute Maximum Ratings may cause permanent damage to the device. This is a stress rating only and functional operation of the device at these or any other conditions above those indicated in the operational section of this specification is not implied. Exposure to absolute maximum rating conditions for extended periods may affect device reliability.

ESD CAUTION



ESD (electrostatic discharge) sensitive device. Charged devices and circuit boards can discharge without detection. Although this product features patented or proprietary protection circuitry, damage may occur on devices subjected to high energy ESD. Therefore, proper ESD precautions should be taken to avoid performance degradation or loss of functionality.

PIN CONFIGURATION AND FUNCTION DESCRIPTIONS

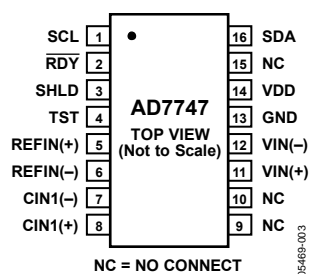

Figure 3. Pin Configuration

Table 4. Pin Function Descriptions

Pin No.	Mnemonic	Description
1	SCL	Serial Interface Clock Input. Connects to the master clock line. Requires pull-up resistor if not already provided in the system.
2	$\overline{\text{RDY}}$	Logic Output. A falling edge on this output indicates that a conversion on enabled channel(s) has been finished and the new data is available. Alternatively, the status register can be read via the 2-wire serial interface and the relevant bit(s) decoded to query the finished conversion. If not used, this pin should be left as an open circuit.
3	SHLD	Capacitive Input Active AC Shielding. To eliminate the CIN parasitic capacitance to ground, the SHLD signal can be used for shielding the connection between the sensor and CIN. If not used, this pin should be left as an open circuit.
4	TST	This pin must be left as an open circuit for proper operation.
5, 6	REFIN(+), REFIN(-)	Differential Voltage Reference Input for the Voltage Channel (ADC). Alternatively, the on-chip internal reference can be used for the voltage channel. These reference input pins are not used for conversion on capacitive channel(s) (CDC). If not used, these pins can be left as an open circuit or connected to GND.
7	CIN1(-)	CDC Negative Capacitive Input. The measured capacitance is connected between the CIN1(-) pin and GND. If not used, this pin should be left as an open circuit.
8	CIN1(+)	CDC Positive Capacitive Input. The measured capacitance is connected between the CIN1(+) pin and GND. If not used, this pin should be left as an open circuit.
9, 10	NC	Not Connected. These pins should be left as an open circuit.
11, 12	VIN(+), VIN(-)	Differential Voltage Input for the Voltage Channel (ADC). These pins are also used to connect an external temperature sensing diode. If not used, these pins can be left as an open circuit or connected to GND.
13	GND	Ground Pin.
14	VDD	Power Supply Voltage. This pin should be decoupled to GND, using a low impedance capacitor, for example in combination with a 10 μF tantalum and a 0.1 μF multilayer ceramic.
15	NC	Not Connected. This pin should be left as an open circuit.
16	SDA	Serial Interface Bidirectional Data. Connects to the master data line. Requires a pull-up resistor if not provided elsewhere in the system.

TYPICAL PERFORMANCE CHARACTERISTICS

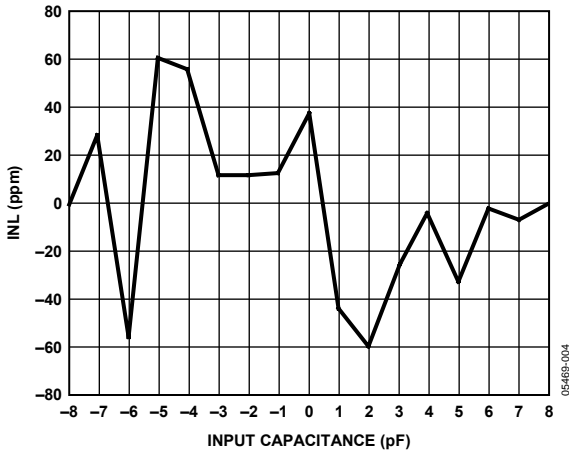

Figure 4. Capacitance Input Integral Nonlinearity; $V_{DD} = 5\text{ V}$, $CAPDAC = 0 \times 3F$

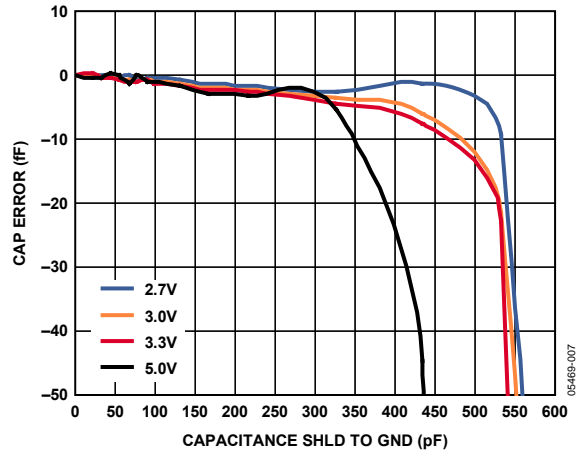

Figure 7. Capacitance Input Error vs. Capacitance Between SHLD and GND; $C_{IN(+)} \text{ to GND} = 8\text{ pF}$, $V_{DD} = 2.7\text{ V}, 3\text{ V}, 3.3\text{ V}, \text{ and } 5\text{ V}$

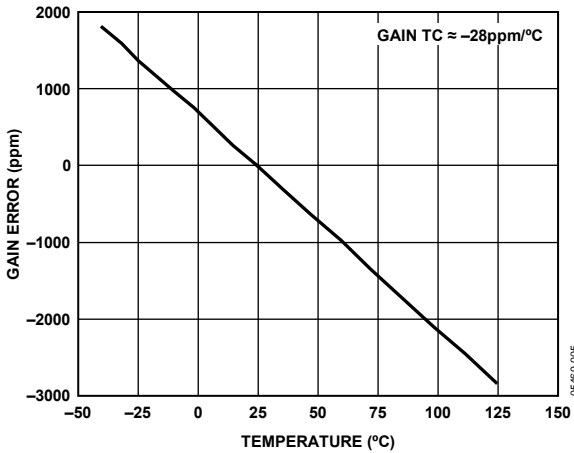

Figure 5. Capacitance Input Gain Drift vs. Temperature; $V_{DD} = 5\text{ V}$, $C_{IN(+)} \text{ to GND} = 8\text{ pF}$

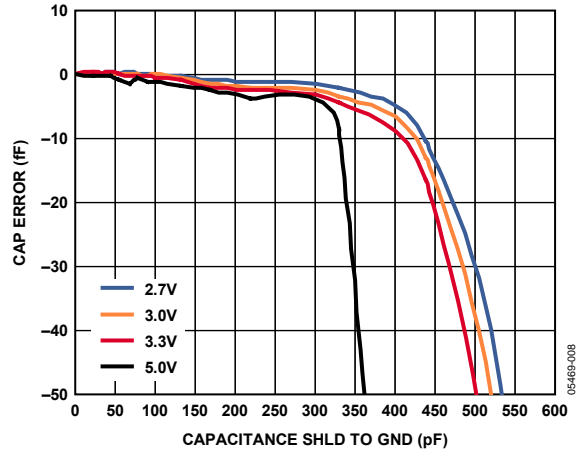

Figure 8. Capacitance Input Error vs. Capacitance Between SHLD and GND; $C_{IN(+)} \text{ to GND} = 25\text{ pF}$, $V_{DD} = 2.7\text{ V}, 3\text{ V}, 3.3\text{ V}, \text{ and } 5\text{ V}$

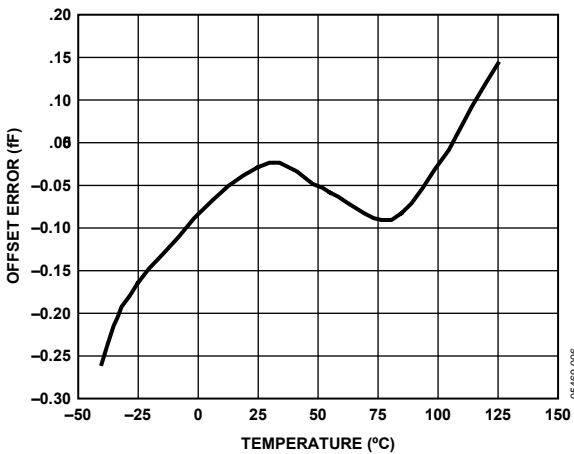

Figure 6. Capacitance Input Offset Drift vs. Temperature; $V_{DD} = 5\text{ V}$, $C_{IN(+)} \text{ Open}$

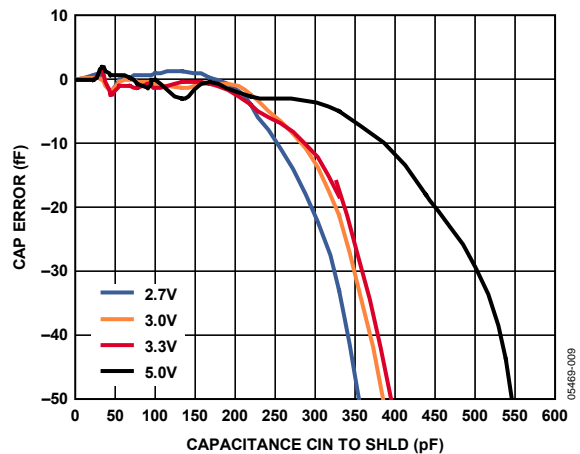

Figure 9. Capacitance Input Error vs. Capacitance Between $C_{IN(+)}$ and SHLD; $C_{IN(+)} \text{ to GND} = 8\text{ pF}$, $V_{DD} = 2.7\text{ V}, 3\text{ V}, 3.3\text{ V}, \text{ and } 5\text{ V}$

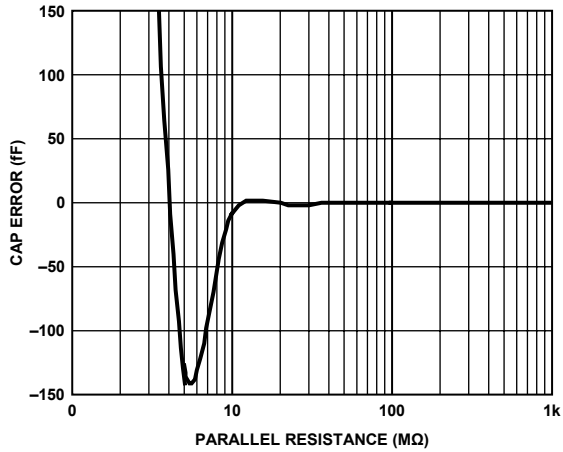

Figure 10. Capacitance Input Error vs. Parallel Resistance; $C_{IN(+)} \text{ to GND} = 8 \text{ pF}$, $V_{DD} = 5 \text{ V}$

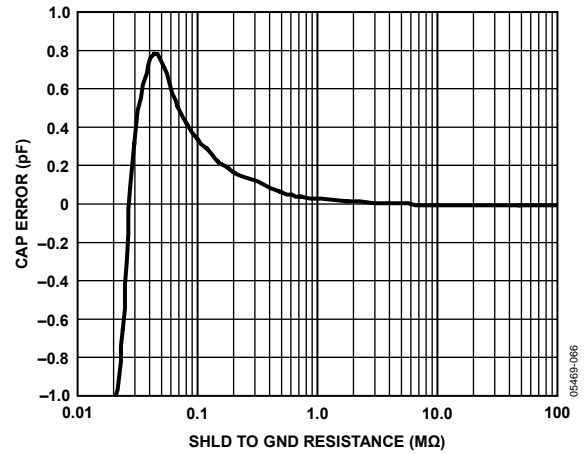

Figure 13. Capacitance Input Error vs. Resistance Between SHLD and GND; $C_{IN(+)} \text{ to GND} = 8 \text{ pF}$; $V_{DD} = 5 \text{ V}$

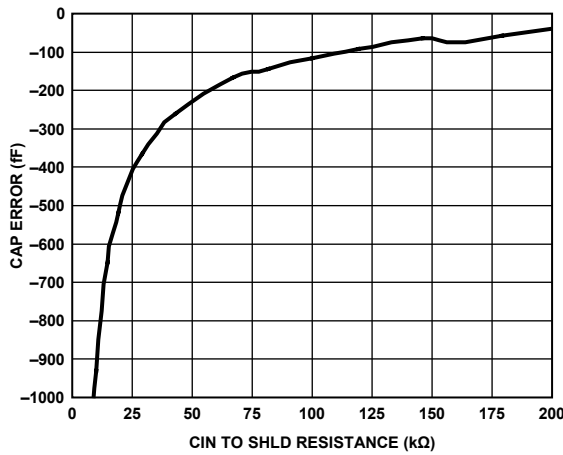

Figure 11. Capacitance Input Error vs. Resistance Between $C_{IN1(+)}$ and SHLD; $C_{IN(+)} \text{ to GND} = 8 \text{ pF}$, $V_{DD} = 5 \text{ V}$

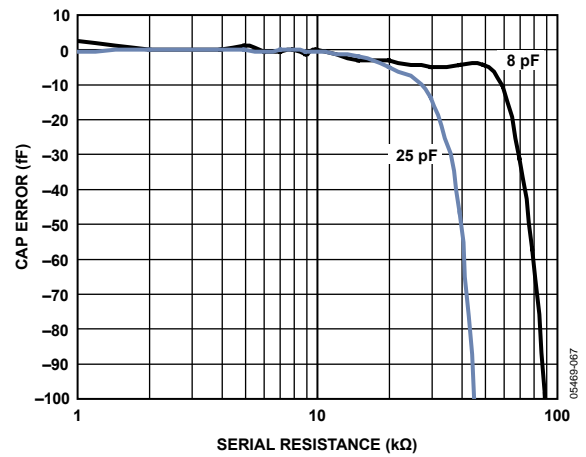

Figure 14. Capacitance Input Error vs. Serial Resistance; $C_{IN(+)} \text{ to GND} = 8 \text{ pF}$ and 25 pF , $V_{DD} = 5 \text{ V}$

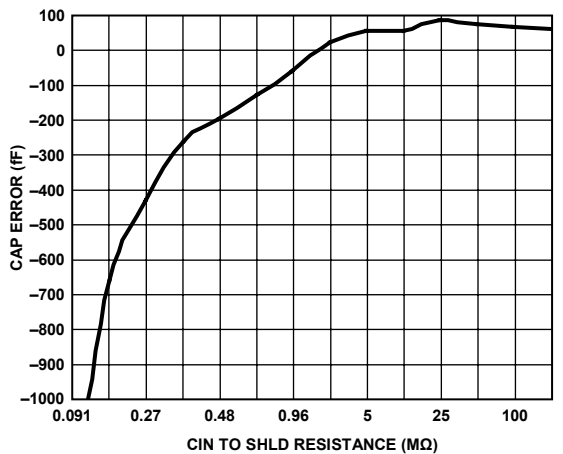

Figure 12. Capacitance Input Error vs. Resistance Between $C_{IN(+)}$ and SHLD; $C_{IN(+)} \text{ to GND} = 25 \text{ pF}$, $V_{DD} = 5 \text{ V}$

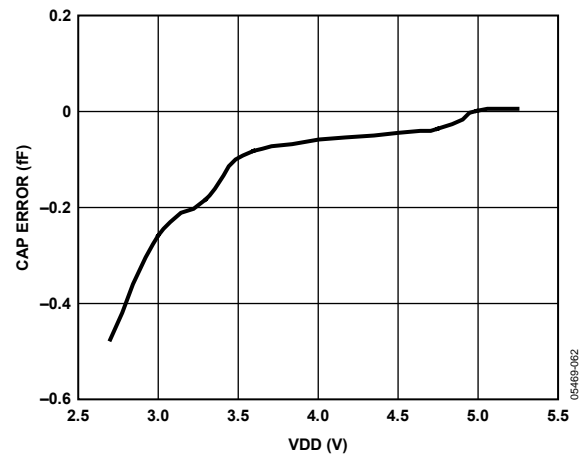

Figure 15. Capacitance Input Power Supply Rejection (PSR); $C_{IN(+)} \text{ to GND} = 8 \text{ pF}$

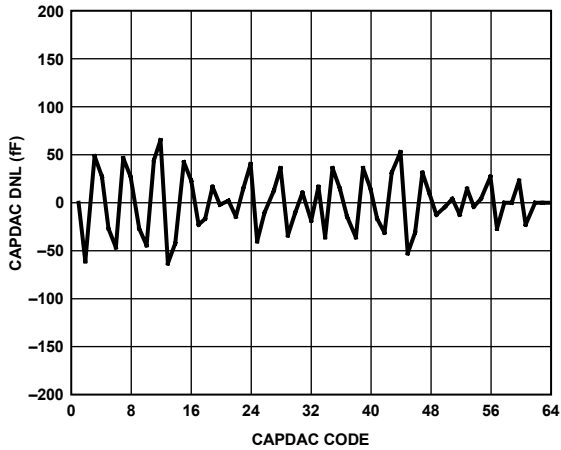

Figure 16. CAPDAC Differential Nonlinearity (DNL)

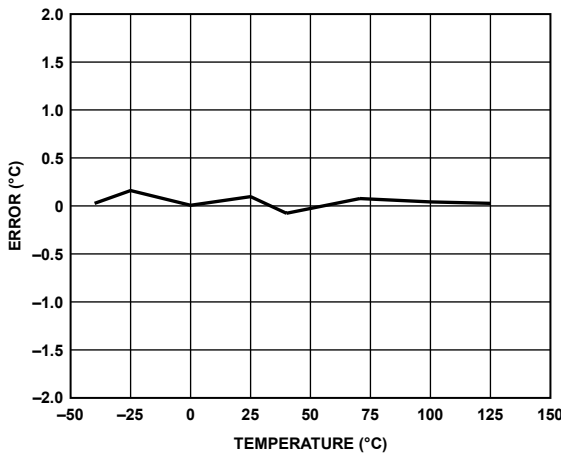

Figure 17. Internal Temperature Sensor Error vs. Temperature

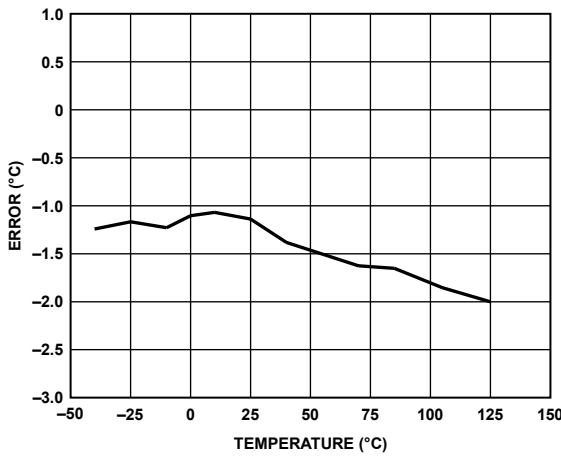

Figure 18. External Temperature Sensor Error vs. Temperature

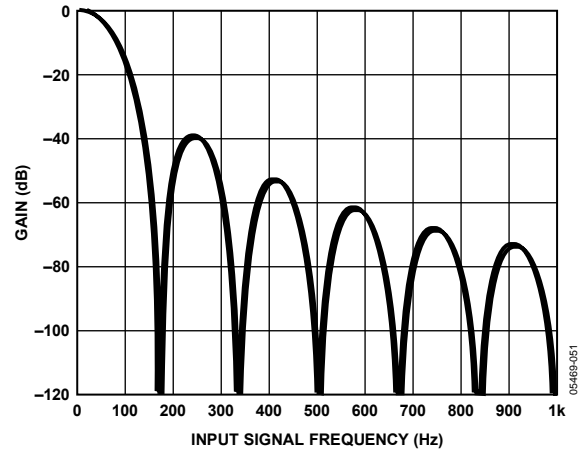

Figure 19. Capacitive Channel Frequency Response; Conversion Time = 22 ms

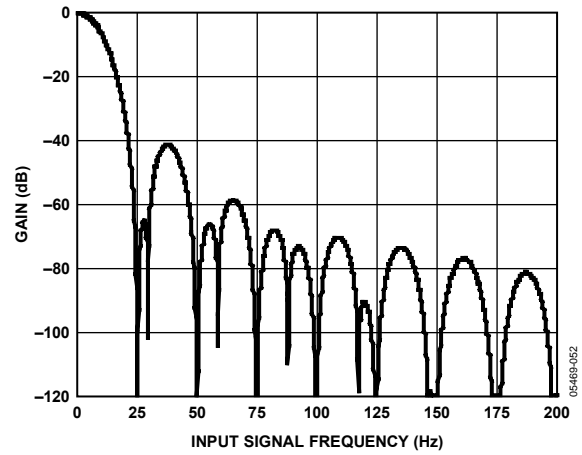

Figure 20. Capacitive Channel Frequency Response; Conversion Time = 124 ms

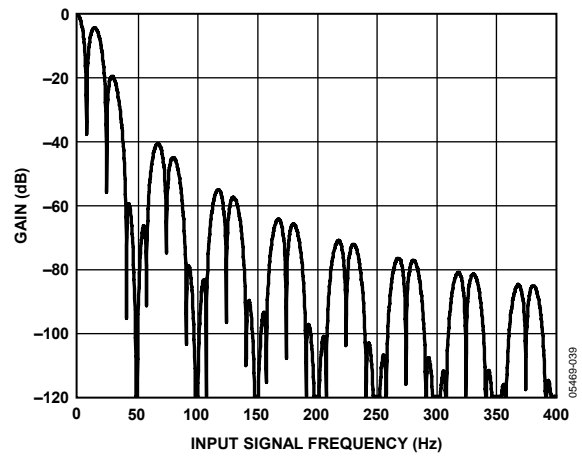

Figure 21. Voltage Channel Frequency Response; Conversion Time = 122.1 ms

OUTPUT NOISE AND RESOLUTION SPECIFICATIONS

The AD7747 resolution is limited by noise. The noise performance varies with the selected conversion time.

Table 5 shows typical noise performance and resolution for the capacitive channel. These numbers were generated from 1000 data samples acquired in continuous conversion mode, at an excitation of 16 kHz, $\pm V_{DD} \times 3/8$, and with all CIN and SHLD pins connected only to the evaluation board (no external capacitors).

Table 6 and Table 7 show typical noise performance and resolution for the voltage channel. These numbers were generated from 1000 data samples acquired in continuous conversion mode with VIN pins shorted to ground.

RMS noise represents the standard deviation and p-p noise represents the difference between minimum and maximum results in the data. Effective resolution is calculated from rms noise, and p-p resolution is calculated from p-p noise.

Table 5. Typical Capacitive Input Noise and Resolution vs. Conversion Time (Bold line represents default setting)

Conversion Time (ms)	Output Data Rate (Hz)	-3 dB Frequency (Hz)	RMS Noise (aF/ $\sqrt{\text{Hz}}$)	RMS Noise (aF)	P-P Noise (aF)	Effective Resolution (Bits)	P-P Resolution (Bits)
22.0	45.5	43.6	28.8	190	821	16.4	14.3
23.9	41.9	39.5	23.2	146	725	16.8	14.5
40.0	25.0	21.8	11.1	52	411	18.3	15.3
76.0	13.2	10.9	11.2	37	262	18.7	15.9
124.0	8.1	6.9	11.0	29	174	19.1	16.5
154.0	6.5	5.3	10.4	24	173	19.3	16.5
184.0	5.4	4.4	10.0	21	141	19.6	16.8
219.3	4.6	4.0	9.0	18	126	19.9	17.0

Table 6. Typical Voltage Input Noise and Resolution vs. Conversion Time, Internal Voltage Reference

Conversion Time (ms)	Output Data Rate (Hz)	-3 dB Frequency (Hz)	RMS Noise (μV)	P-P Noise (μV)	Effective Resolution (Bits)	P-P Resolution (Bits)
20.1	49.8	26.4	11.4	62	17.6	15.2
32.1	31.2	15.9	7.1	42	18.3	15.7
62.1	16.1	8.0	4.0	28	19.1	16.3
122.1	8.2	4.0	3.0	20	19.5	16.8

Table 7. Typical Voltage Input Noise and Resolution vs. Conversion Time, External 2.5 V Voltage Reference

Conversion Time (ms)	Output Data Rate (Hz)	-3 dB Frequency (Hz)	RMS Noise (μV)	P-P Noise (μV)	Effective Resolution (Bits)	P-P Resolution (Bits)
20.1	49.8	26.4	14.9	95	18.3	15.6
32.1	31.2	15.9	6.3	42	19.6	16.8
62.1	16.1	8.0	3.3	22	20.5	17.7
122.1	8.2	4.0	2.1	15	21.1	18.3

SERIAL INTERFACE

The AD7747 supports an I²C-compatible 2-wire serial interface. The two wires on the I²C bus are called SCL (clock) and SDA (data). These two wires carry all addressing, control, and data information one bit at a time over the bus to all connected peripheral devices. The SDA wire carries the data, while the SCL wire synchronizes the sender and receiver during the data transfer. I²C devices are classified as either master or slave devices. A device that initiates a data transfer message is called a master, while a device that responds to this message is called a slave.

To control the AD7747 device on the bus, the following protocol must be followed. First, the master initiates a data transfer by establishing a start condition, defined by a high-to-low transition on SDA while SCL remains high. This indicates that the start byte follows. This 8-bit start byte is made up of a 7-bit address plus an R/W bit indicator.

All peripherals connected to the bus respond to the start condition and shift in the next 8 bits (7-bit address + R/W bit). The bits arrive MSB first. The peripheral that recognizes the transmitted address responds by pulling the data line low during the ninth clock pulse. This is known as the acknowledge bit. All other devices withdraw from the bus at this point and maintain an idle condition. An exception to this is the general call address, which is described later in this document. The idle condition is where the device monitors the SDA and SCL lines waiting for the start condition and the correct address byte. The R/W bit determines the direction of the data transfer. A Logic 0 LSB in the start byte means that the master writes information to the addressed peripheral. In this case, the AD7747 becomes a slave receiver. A Logic 1 LSB in the start byte means that the master reads information from the addressed peripheral. In this case, the AD7747 becomes a slave transmitter. In all instances, the AD7747 acts as a standard slave device on the I²C bus.

The start byte address for the AD7747 is 0x90 for a write and 0x91 for a read.

READ OPERATION

When a read is selected in the start byte, the register that is currently addressed by the address pointer is transmitted on to the SDA line by the AD7747. This is then clocked out by the master device and the AD7747 awaits an acknowledge from the master.

If an acknowledge is received from the master, the address auto-incrementer automatically increments the address pointer register and outputs the next addressed register content on to the SDA line for transmission to the master. If no acknowledge is received, the AD7747 returns to the idle state and the address pointer is not incremented.

The address pointer's auto-incrementer allows block data to be written or read from the starting address and subsequent incremental addresses.

In continuous conversion mode, the address pointer's auto-incrementer should be used for reading a conversion result. That means the three data bytes should be read using one multibyte read transaction rather than three separate single byte transactions. The single byte data read transaction may result in the data bytes from two different results being mixed. The same applies for six data bytes if both the capacitive and the voltage/temperature channel are enabled.

The user can also access any unique register (address) on a one-to-one basis without having to update all the registers. The address pointer register's contents cannot be read.

If an incorrect address pointer location is accessed, or if the user allows the auto-incrementer to exceed the required register address, the following applies:

- In read mode, the AD7747 continues to output various internal register contents until the master device issues a no acknowledge, start, or stop condition. The address pointer auto-incrementer's contents are reset to point to the status register at Address 0x00 when a stop condition is received at the end of a read operation. This allows the status register to be read (polled) continually without having to constantly write to the address pointer.
- In write mode, the data for the invalid address is not loaded into the AD7747 registers, but an acknowledge is issued by the AD7747.

WRITE OPERATION

When a write is selected, the byte following the start byte is always the register address pointer (subaddress) byte, which points to one of the internal registers on the AD7747. The address pointer byte is automatically loaded into the address pointer register and acknowledged by the AD7747. After the address pointer byte acknowledge, a stop condition, a repeated start condition, or another data byte can follow from the master.

A stop condition is defined by a low-to-high transition on SDA while SCL remains high. If a stop condition is ever encountered by the AD7747, it returns to its idle condition and the address pointer is reset to Address 0x00.

If a data byte is transmitted after the register address pointer byte, the AD7747 loads this byte into the register that is currently addressed by the address pointer register, sends an acknowledge, and the address pointer auto-incrementer automatically increments the address pointer register to the next internal register address. Thus, subsequent transmitted data bytes are loaded into sequentially incremented addresses.

If a repeated start condition is encountered after the address pointer byte, all peripherals connected to the bus respond exactly as outlined above for a start condition, that is, a repeated start condition is treated the same as a start condition. When a master device issues a stop condition, it relinquishes control of

the bus, allowing another master device to take control of the bus. Therefore, a master wanting to retain control of the bus issues successive start conditions known as repeated start conditions.

AD7747 RESET

To reset the AD7747 without having to reset the entire I²C bus, an explicit reset command is provided. This uses a particular address pointer word as a command word to reset the part and upload all default settings. The AD7747 does not respond to the I²C bus commands (do not acknowledge) during the default values upload for approximately 150 μs (max 200 μs).

The reset command address word is 0xBF.

GENERAL CALL

When a master issues a slave address consisting of seven 0s with the eighth bit (R/W bit) set to 0, this is known as the general call address. The general call address is for addressing every device connected to the I²C bus. The AD7747 acknowledges this address and read in the following data byte.

If the second byte is 0x06, the AD7747 is reset, completely uploading all default values. The AD7747 does not respond to the I²C bus commands (do not acknowledge) during the default values upload for approximately 150 μs (200 μs maximum).

The AD7747 does not acknowledge any other general call commands.

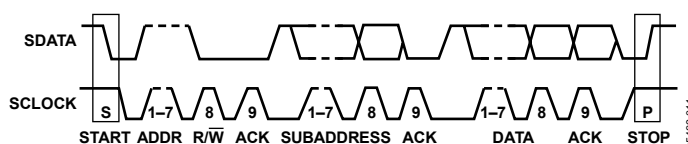

Figure 22. Bus Data Transfer

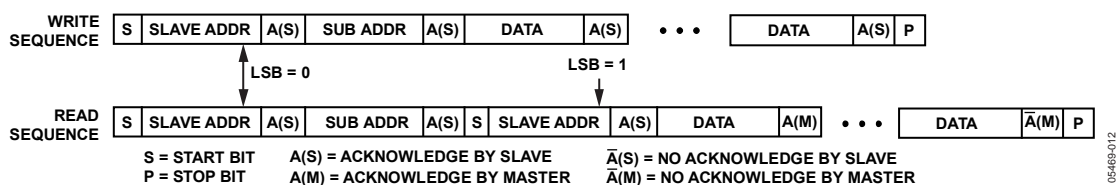

Figure 23. Write and Read Sequences

REGISTER DESCRIPTIONS

The master can write to or read from all of the AD7747 registers except the address pointer register, which is a write-only register. The address pointer register determines which register the next read or write operation accesses. All communications with the part through the bus start with an access to the address pointer register. After the part has been accessed over the bus

and a read/write operation is selected, the address pointer register is set up. The address pointer register determines from or to which register the operation takes place. A read/write operation is performed from/to the target address, which then increments to the next address until a stop command on the bus is performed.

Table 8. Register Summary

Register	Address Pointer		Dir	Bit 7	Bit 6	Bit 5	Bit 4	Bit 3	Bit 2	Bit 1	Bit 0
	(Dec)	(Hex)		Default Value							
Status	0	0x00	R	– 0	– 0	– 0	– 0	– 0	RDY 1	RDYVT 1	RDYCAP 1
Cap Data H	1	0x01	R	Capacitive channel data—high byte, 0x00							
Cap Data M	2	0x02	R	Capacitive channel data—middle byte, 0x00							
Cap Data L	3	0x03	R	Capacitive channel data—low byte, 0x00							
VT Data H	4	0x04	R	Voltage/temperature channel data—high byte, 0x00							
VT Data M	5	0x05	R	Voltage/temperature channel data—middle byte, 0x00							
VT Data L	6	0x06	R	Voltage/temperature channel data—low byte, 0x00							
Cap Setup	7	0x07	R/W	CAPEN 0	– 0	CAPDIFF 0	– 0	– 0	– 0	– 0	– 0
VT Setup	8	0x08	R/W	VTEN 0	VTMD1 0	VTMD0 0	EXTREF 0	– 0	– 0	VTSHORT 0	VTCHOP 0
EXC Setup	9	0x09	R/W	– 0	– 0	– 0	– 0	EXCDAC 0	EXCEN 0	EXCLVL1 1	EXCLVL0 1
Configuration	10	0x0A	R/W	VTFS1 1	VTFS0 0	CAPFS2 1	CAPFS1 0	CAPFS0 0	MD2 0	MD1 0	MD0 0
Cap DAC A	11	0x0B	R/W	DACAENA 0	– 0	DACA—6-Bit Value 0x00					
Cap DAC B	12	0x0C	R/W	DACBENB 0	– 0	DACB—6-Bit Value 0x00					
Cap Offset H	13	0x0D	R/W	Capacitive offset calibration—high byte, 0x80							
Cap Offset L	14	0x0E	R/W	Capacitive offset calibration—low byte, 0x00							
Cap Gain H	15	0x0F	R/W	Capacitive gain calibration—high byte, factory calibrated							
Cap Gain L	16	0x10	R/W	Capacitive gain calibration—low byte, factory calibrated							
Volt Gain H	17	0x11	R/W	Voltage gain calibration—high byte, factory calibrated							
Volt Gain L	18	0x12	R/W	Voltage gain calibration—low byte, factory calibrated							

STATUS REGISTER

Address Pointer 0x00, Read Only, Default Value 0x07

This register indicates the status of the converter. The status register can be read via the 2-wire serial interface to query a finished conversion.

The $\overline{\text{RDY}}$ pin reflects the status of the RDY bit. Therefore, the $\overline{\text{RDY}}$ pin high-to-low transition can be used as an alternative indication of the finished conversion.

Table 9. Status Register Bit Map

Bit	Bit 7	Bit 6	Bit 5	Bit 4	Bit 3	Bit 2	Bit 1	Bit 0
Mnemonic	–	–	–	–	–	RDY	RDYVT	RDYCAP
Default	0	0	0	0	0	1	1	1

Table 10.

Bit	Mnemonic	Description
7 to 3	–	Not used, always read 0.
2	RDY	RDY = 0 indicates that conversion on the enabled channel(s) is complete and new unread data is available. If both capacitive and voltage/temperature channels are enabled, the RDY bit is changed to 0 after conversion on both channels is complete. The RDY bit returns to 1 either when data is read or prior to finishing the next conversion. If, for example, only the capacitive channel is enabled, then the RDY bit reflects the RDYCAP bit.
1	RDYVT	RDYVT = 0 indicates that a conversion on the voltage/temperature channel is complete and new unread data is available.
0	RDYCAP	RDYCAP = 0 indicates that a conversion on the capacitive channel is complete and new unread data is available.

CAP DATA REGISTER

24 Bits, Address Pointer 0x01, 0x02, 0x03, Read-Only, Default Value 0x000000

This register contains the capacitive channel output data. The register is updated after finished conversion on the capacitive channel, with one exception: When the serial interface read operation from the Cap Data register is in progress, the data register is not updated and the new capacitance conversion result is lost.

The stop condition on the serial interface is considered to be the end of the read operation. Therefore, to prevent data corruption, all three bytes of the data register should be read sequentially using the register address pointer auto-increment feature of the serial interface.

To prevent losing some of the results, the Cap Data register should be read before the next conversion on the capacitive channel is finished.

The 0x000000 code represents negative full scale (–8.192 pF), the 0x800000 code represents zero scale (0 pF), and the 0xFFFFFFFF code represents positive full scale (+8.192 pF).

VT DATA REGISTER

24 Bits, Address Pointer 0x04, 0x05, 0x06, Read-Only, Default Value 0x000000

This register contains the voltage/temperature channel output data. The register is updated after finished conversion on the voltage channel or temperature channel, with one exception: When the serial interface read operation from the VT Data register is in progress, the data register is not updated and the new voltage/temperature conversion result is lost.

The stop condition on the serial interface is considered to be the end of the read operation. Therefore, to prevent data corruption, all three bytes of the data register should be read sequentially using the register address pointer auto-increment feature of the serial interface.

For voltage input, Code 0 represents negative full scale ($-V_{\text{REF}}$), the 0x800000 code represents zero scale (0 V), and the 0xFFFFFFFF code represents positive full scale ($+V_{\text{REF}}$).

To prevent losing some of the results, the VT Data register should be read before the next conversion on the voltage/temperature channel is complete.

For the temperature sensor, the temperature can be calculated from code using the following equation:

$$\text{Temperature (}^{\circ}\text{C)} = (\text{Code}/2048) - 4096$$

CAP SETUP REGISTER

Address Pointer 0x07, Default Value 0x00

Capacitive channel setup.

Table 11. Cap Setup Register Bit Map

Bit	Bit 7	Bit 6	Bit 5	Bit 4	Bit 3	Bit 2	Bit 1	Bit 0
Mnemonic	CAPEN	–	CAPDIFF	–	–	–	–	–
Default	0	0	0	0	0	0	0	0

Table 12.

Bit	Mnemonic	Description
7	CAPEN	CAPEN = 1 enables capacitive channel for single conversion, continuous conversion, or calibration.
6	–	This bit must be 0 for proper operation.
5	CAPDIFF	This bit must be set to 1 for proper operation.
4 to 0	–	These bits must be 0 for proper operation.

VT SETUP REGISTER

Address Pointer 0x08, Default Value 0x00

Voltage/Temperature channel setup.

Table 13. VT Setup Register Bit Map

Bit	Bit 7	Bit 6	Bit 5	Bit 4	Bit 3	Bit 2	Bit 1	Bit 0
Mnemonic	VTEN	VTMD1	VTMD0	EXTREF	–	–	VTSHORT	VTCHOP
Default	0	0	0	0	0	0	0	0

Table 14.

Bit	Mnemonic	Description		
7	VTEN	VTEN = 1 enables voltage/temperature channel for single conversion, continuous conversion, or calibration.		
6	VTMD1	Voltage/temperature channel input configuration.		
5	VTMD0			
	VTMD1		VTMD0	Channel Input
	0		0	Internal temperature sensor
	0		1	External temperature sensor diode
	1	0	V _{DD} monitor	
	1	1	External voltage input (VIN)	
4	EXTREF	EXTREF = 1 selects an external reference voltage connected to REFIN(+), REFIN(–) for the voltage input or the V _{DD} monitor. EXTREF = 0 selects the on-chip internal reference. The internal reference must be used with the internal temperature sensor for proper operation.		
3 to 2	–	These bits must be 0 for proper operation.		
1	VTSHORT	VTSHORT = 1 internally shorts the voltage/temperature channel input for test purposes.		
0	VTCHOP = 1	VTCHOP = 1 sets internal chopping on the voltage/temperature channel. The VTCHOP bit must be set to 1 for the specified voltage/temperature channel performance.		

EXC SETUP REGISTER**Address Pointer 0x09, Default Value 0x03**

Capacitive channel excitation setup.

Table 15. EXC Setup Bit Map

Bit	Bit 7	Bit 6	Bit 5	Bit 4	Bit 3	Bit 2	Bit 1	Bit 0
Mnemonic	–	–	–	–	EXCDAC	EXCEN	EXCLVL1	EXCLVLO
Default	0	0	0	0	0	0	1	1

Table 16.

Bit	Mnemonic	Description																									
7 to 4	–	These bits must be 0 for proper operation.																									
3	EXCDAC	CAPDAC excitation. This bit must be set to 1 for the proper capacitive channel operation.																									
2	EXCEN	CIN and AC SHLD excitation. This bit must be set to 1 for the proper capacitive channel operation.																									
1 0	EXCLVL1, EXCLVLO	Excitation Voltage Level. Must be set to $\pm V_{DD} \times 3/8$ to allow operation for specified performance.																									
		<table border="1"> <thead> <tr> <th>EXCLVL1</th> <th>EXCLVLO</th> <th>Voltage on Cap</th> <th>EXC Low Level</th> <th>EXC High Level</th> </tr> </thead> <tbody> <tr> <td>0</td> <td>0</td> <td>$\pm V_{DD}/8$</td> <td>$V_{DD} \times 3/8$</td> <td>$V_{DD} \times 5/8$</td> </tr> <tr> <td>0</td> <td>1</td> <td>$\pm V_{DD}/4$</td> <td>$V_{DD} \times 1/4$</td> <td>$V_{DD} \times 3/4$</td> </tr> <tr> <td>1</td> <td>0</td> <td>$\pm V_{DD} \times 3/8$</td> <td>$V_{DD} \times 1/8$</td> <td>$V_{DD} \times 7/8$</td> </tr> <tr> <td>1</td> <td>1</td> <td>$\pm V_{DD}/2$</td> <td>0</td> <td>V_{DD}</td> </tr> </tbody> </table>	EXCLVL1	EXCLVLO	Voltage on Cap	EXC Low Level	EXC High Level	0	0	$\pm V_{DD}/8$	$V_{DD} \times 3/8$	$V_{DD} \times 5/8$	0	1	$\pm V_{DD}/4$	$V_{DD} \times 1/4$	$V_{DD} \times 3/4$	1	0	$\pm V_{DD} \times 3/8$	$V_{DD} \times 1/8$	$V_{DD} \times 7/8$	1	1	$\pm V_{DD}/2$	0	V_{DD}
EXCLVL1	EXCLVLO	Voltage on Cap	EXC Low Level	EXC High Level																							
0	0	$\pm V_{DD}/8$	$V_{DD} \times 3/8$	$V_{DD} \times 5/8$																							
0	1	$\pm V_{DD}/4$	$V_{DD} \times 1/4$	$V_{DD} \times 3/4$																							
1	0	$\pm V_{DD} \times 3/8$	$V_{DD} \times 1/8$	$V_{DD} \times 7/8$																							
1	1	$\pm V_{DD}/2$	0	V_{DD}																							

AD7747

CONFIGURATION REGISTER

Address Pointer 0x0A, Default Value 0xA0

Converter update rate and mode of operation setup.

Table 17. Configuration Register Bit Map

Bit	Bit 7	Bit 6	Bit 5	Bit 4	Bit 3	Bit 2	Bit 1	Bit 0
Mnemonic	VTFS1	VTFS0	CAPFS2	CAPFS1	CAPFS0	MD2	MD1	MD0
Default	0	0	0	0	0	0	0	0

Table 18.

Bit	Mnemonic	Description																																																						
7 6	VTFS1 VTFS0	Voltage/temperature channel digital filter setup—conversion time/update rate setup.																																																						
		VTCHOP = 1																																																						
		<table border="1" style="width: 100%; border-collapse: collapse;"> <thead> <tr> <th>VTFS1</th> <th>VTFS0</th> <th>Conversion Time (ms)</th> <th>Update Rate (Hz)</th> <th>–3 dB Frequency (Hz)</th> </tr> </thead> <tbody> <tr> <td>0</td> <td>0</td> <td>20.1</td> <td>49.8</td> <td>26.4</td> </tr> <tr> <td>0</td> <td>1</td> <td>32.1</td> <td>31.2</td> <td>15.9</td> </tr> <tr> <td>1</td> <td>0</td> <td>62.1</td> <td>16.1</td> <td>8.0</td> </tr> <tr> <td>1</td> <td>1</td> <td>122.1</td> <td>8.2</td> <td>4.0</td> </tr> </tbody> </table>	VTFS1	VTFS0	Conversion Time (ms)	Update Rate (Hz)	–3 dB Frequency (Hz)	0	0	20.1	49.8	26.4	0	1	32.1	31.2	15.9	1	0	62.1	16.1	8.0	1	1	122.1	8.2	4.0																													
VTFS1	VTFS0	Conversion Time (ms)	Update Rate (Hz)	–3 dB Frequency (Hz)																																																				
0	0	20.1	49.8	26.4																																																				
0	1	32.1	31.2	15.9																																																				
1	0	62.1	16.1	8.0																																																				
1	1	122.1	8.2	4.0																																																				
5 4 3	CAPFS2 CAPFS1 CAPFS0	Capacitive channel digital filter setup—conversion time/update rate setup.																																																						
		<table border="1" style="width: 100%; border-collapse: collapse;"> <thead> <tr> <th>CAPFS2</th> <th>CAPFS1</th> <th>CAPFS0</th> <th>Conversion Time (ms)</th> <th>Update Rate</th> <th>–3 dB Frequency (Hz)</th> </tr> </thead> <tbody> <tr> <td>0</td> <td>0</td> <td>0</td> <td>22.0</td> <td>45.5</td> <td>43.6</td> </tr> <tr> <td>0</td> <td>0</td> <td>1</td> <td>23.9</td> <td>41.9</td> <td>39.5</td> </tr> <tr> <td>0</td> <td>1</td> <td>0</td> <td>40.0</td> <td>25.0</td> <td>21.8</td> </tr> <tr> <td>0</td> <td>1</td> <td>1</td> <td>76.0</td> <td>13.2</td> <td>10.9</td> </tr> <tr> <td>1</td> <td>0</td> <td>0</td> <td>124.0</td> <td>8.1</td> <td>6.9</td> </tr> <tr> <td>1</td> <td>0</td> <td>1</td> <td>154.0</td> <td>6.5</td> <td>5.3</td> </tr> <tr> <td>1</td> <td>1</td> <td>0</td> <td>184.0</td> <td>5.5</td> <td>4.4</td> </tr> <tr> <td>1</td> <td>1</td> <td>1</td> <td>219.3</td> <td>4.6</td> <td>4.0</td> </tr> </tbody> </table>	CAPFS2	CAPFS1	CAPFS0	Conversion Time (ms)	Update Rate	–3 dB Frequency (Hz)	0	0	0	22.0	45.5	43.6	0	0	1	23.9	41.9	39.5	0	1	0	40.0	25.0	21.8	0	1	1	76.0	13.2	10.9	1	0	0	124.0	8.1	6.9	1	0	1	154.0	6.5	5.3	1	1	0	184.0	5.5	4.4	1	1	1	219.3	4.6	4.0
CAPFS2	CAPFS1	CAPFS0	Conversion Time (ms)	Update Rate	–3 dB Frequency (Hz)																																																			
0	0	0	22.0	45.5	43.6																																																			
0	0	1	23.9	41.9	39.5																																																			
0	1	0	40.0	25.0	21.8																																																			
0	1	1	76.0	13.2	10.9																																																			
1	0	0	124.0	8.1	6.9																																																			
1	0	1	154.0	6.5	5.3																																																			
1	1	0	184.0	5.5	4.4																																																			
1	1	1	219.3	4.6	4.0																																																			
2 1 0	MD2 MD1 MD0	Converter mode of operation setup.																																																						
		<table border="1" style="width: 100%; border-collapse: collapse;"> <thead> <tr> <th>MD2</th> <th>MD1</th> <th>MD0</th> <th>Mode</th> </tr> </thead> <tbody> <tr> <td>0</td> <td>0</td> <td>0</td> <td>Idle</td> </tr> <tr> <td>0</td> <td>0</td> <td>1</td> <td>Continuous conversion</td> </tr> <tr> <td>0</td> <td>1</td> <td>0</td> <td>Single conversion</td> </tr> <tr> <td>0</td> <td>1</td> <td>1</td> <td>Power-down</td> </tr> <tr> <td>1</td> <td>0</td> <td>0</td> <td>–</td> </tr> <tr> <td>1</td> <td>0</td> <td>1</td> <td>Capacitance system offset calibration</td> </tr> <tr> <td>1</td> <td>1</td> <td>0</td> <td>Capacitance or voltage system gain calibration</td> </tr> <tr> <td>1</td> <td>1</td> <td>1</td> <td>–</td> </tr> </tbody> </table>	MD2	MD1	MD0	Mode	0	0	0	Idle	0	0	1	Continuous conversion	0	1	0	Single conversion	0	1	1	Power-down	1	0	0	–	1	0	1	Capacitance system offset calibration	1	1	0	Capacitance or voltage system gain calibration	1	1	1	–																		
MD2	MD1	MD0	Mode																																																					
0	0	0	Idle																																																					
0	0	1	Continuous conversion																																																					
0	1	0	Single conversion																																																					
0	1	1	Power-down																																																					
1	0	0	–																																																					
1	0	1	Capacitance system offset calibration																																																					
1	1	0	Capacitance or voltage system gain calibration																																																					
1	1	1	–																																																					

CAP DAC A REGISTER**Address Pointer 0x0B, Default Value 0x00**

Capacitive DAC setup.

Table 19. Cap DAC A Register Bit Map

Bit	Bit 7	Bit 6	Bit 5	Bit 4	Bit 3	Bit 2	Bit 1	Bit 0
Mnemonic	DACAENA	–	DACA—6-Bit Value					
Default	0	0	0x00					

Table 20.

Bit	Mnemonic	Description
7	DACAENA	DACAENA = 1 connects capacitive DACA to the positive capacitance input.
6	–	This bit must be 0 for proper operation.
5 to 1	DACA	DACA value, Code 0x00 ≈ 0 pF, Code 0x3F ≈ full range.

CAP DAC B REGISTER**Address Pointer 0x0C, Default Value 0x00**

Capacitive DAC setup.

Table 21. Cap DAC B Register Bit Map

Bit	Bit 7	Bit 6	Bit 5	Bit 4	Bit 3	Bit 2	Bit 1	Bit 0
Mnemonic	DACBENB	–	DACB—6-Bit Value					
Default	0	0	0x00					

Table 22.

Bit	Mnemonic	Description
7	DACBENB	DACBENB = 1 connects capacitive DACB to the negative capacitance input.
6	–	This bit must be 0 for proper operation.
5 to 1	DACB	DACB value, Code 0x00 ≈ 0 pF, Code 0x3F ≈ full range.

CAP OFFSET CALIBRATION REGISTER

**16 Bits, Address Pointer 0x0D, 0x0E,
Default Value 0x8000**

The capacitive offset calibration register holds the capacitive channel zero-scale calibration coefficient. The coefficient is used to digitally remove the capacitive channel offset. The register value is updated automatically following the execution of a capacitance offset calibration. The capacitive offset calibration resolution (cap offset register LSB) is less than 32 aF; the full range is ± 1 pF.

CAP GAIN CALIBRATION REGISTER

**16 Bits, Address Pointer 0x0F, 0x10,
Default Value 0xFFFF**

Capacitive gain calibration register. The register holds the capacitive channel full-scale factory calibration coefficient.

VOLT GAIN CALIBRATION REGISTER

**16 Bits, Address Pointer 0x11, 0x12,
Default Value 0xFFFF**

Voltage gain calibration register. The register holds the voltage channel full-scale factory calibration coefficient.

CIRCUIT DESCRIPTION

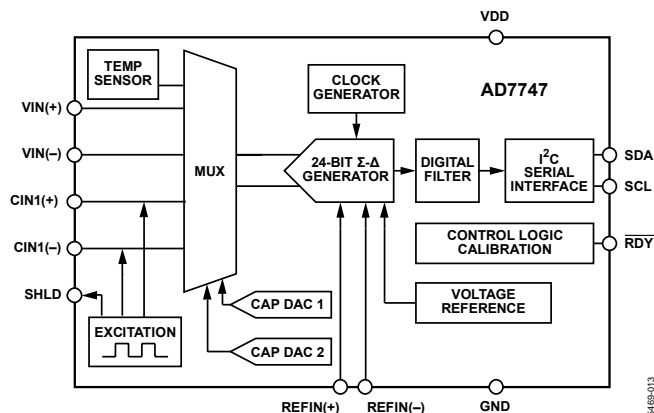

Figure 24. AD7747 Block Diagram

OVERVIEW

The AD7747 core is a high precision converter consisting of a second-order (Σ - Δ or charge balancing) modulator and a third-order digital filter. It works as a CDC for the capacitive inputs and as a classic ADC for the voltage input or for the voltage from a temperature sensor.

In addition to the converter, the AD7747 integrates a multiplexer, an excitation source and CAPDACs for the capacitive inputs, a temperature sensor and a voltage reference for the voltage and temperature inputs, a complete clock generator, a control and calibration logic, and an I²C-compatible serial interface.

CAPACITANCE-TO-DIGITAL CONVERTER

Figure 25 shows the CDC simplified functional diagram. The measured capacitance C_x is connected between the Σ - Δ modulator input and ground. A square-wave excitation signal is applied on the C_x during the conversion and the modulator continuously samples the charge going through the C_x . The digital filter processes the modulator output, which is a stream of 0s and 1s containing the information in 0 and 1 density. The data from the digital filter is scaled, applying the calibration coefficients, and the final result can be read through the serial interface.

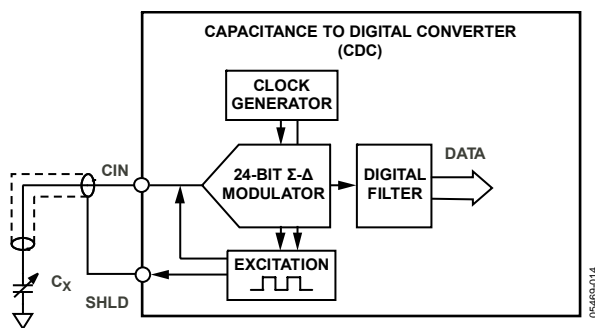

Figure 25. CDC Simplified Block Diagram

ACTIVE AC SHIELD CONCEPT

The AD7747 measures capacitance between CIN and ground. That means any capacitance to ground on signal path between the AD7747 CIN pin(s) and sensor is included in the AD7747 conversion result.

The parasitic capacitance of the sensor connections can easily be in the same, if not even higher, order as the capacitance of the sensor itself. If that parasitic capacitance is stable, it can be treated as a nonchanging capacitive offset. However, the parasitic capacitance of sensor connections is often changing as a result of mechanical movement, changing ambient temperature, ambient humidity, etc. These changes are seen as drift in the conversion result and may significantly compromise the system accuracy.

To eliminate the CIN parasitic capacitance to ground, the AD7747 SHLD signal can be used for shielding the connection between the sensor and CIN, as shown in Figure 25. The SHLD output is basically the same signal waveform as the excitation of the CIN pin; the SHLD is driven to the same voltage potential as the CIN pin. Therefore, there is no ac current between CIN and SHLD pins, and any capacitance between these pins does not affect the CIN charge transfer. Ideally, the CIN to SHLD capacitance does not have any contribution to the AD7747 result.

To get the best result, locate the AD7747 as close as possible to the capacitive sensor. Keep the connection between the sensor and AD7747 CIN pin, and also the return path between sensor ground and the AD7747 GND pin, short. Shield the PCB track to the CIN pin and connect the shielding to the AD7747 SHLD pin. In addition, if a shielded cable is used for sensor connection, the shield should be connected to the AD7747 SHLD pin.

CAPDAC

The AD7747 CDC full-scale input range is ± 8.192 pF. For simplicity of calculation, however, the following text and figures use ± 8 pF. The part can accept a higher capacitance on the input and the common-mode or offset (nonchanging component) capacitance can be balanced by programmable on-chip CAPDACs.

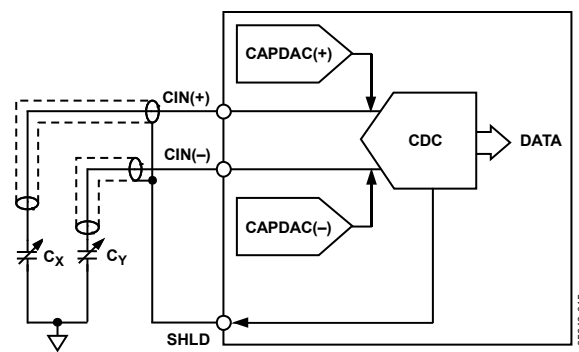

Figure 26. Using a CAPDAC

The CAPDAC can be understood as a negative capacitance connected internally to the CIN pin. There are two independent CAPDACs, one connected to the CIN(+) and the second connected to the CIN(-). The relation between the capacitance input and output data can be expressed as

$$DATA \approx (C_X - CAPDAC(+)) - (C_Y - CAPDAC(-))$$

The CAPDACs have a 6-bit resolution, monotonic transfer function, are well matched to each other, and have a defined temperature coefficient. The CAPDAC full range (absolute value) is not factory calibrated and can vary up to $\pm 20\%$ with the manufacturing process. See the Specifications section and Figure 16 of the typical performance characteristics.

SINGLE-ENDED CAPACITIVE CONFIGURATION

The AD7747 can be used for interfacing to a single-ended capacitive sensor. In this configuration the sensor should be connected to one of the AD7747 CIN pins, for example CIN(+), and the other pin should be left open circuit. Note that the CAPDIFF bit in the Cap Setup register must be set to 1 at all times for the correct operation.

It is recommended to guard the unused CIN input with the active shield to ensure the best performance in terms of noise, offset, and offset drift.

The CDC (without using the CAPDACs) measure the positive (or the negative) input capacitance in the range of 0 pF to 8 pF (see Figure 27).

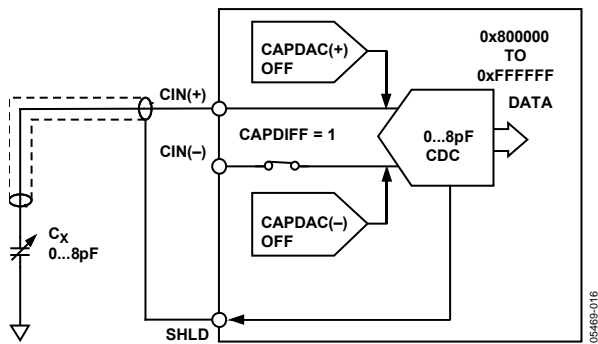

Figure 27. CDC Single-Ended Input Configuration

The CAPDAC can be used for programmable shifting of the input range. The example in Figure 28 shows how to use the full ± 8 pF CDC span to measure capacitance between 0 pF to 16 pF.

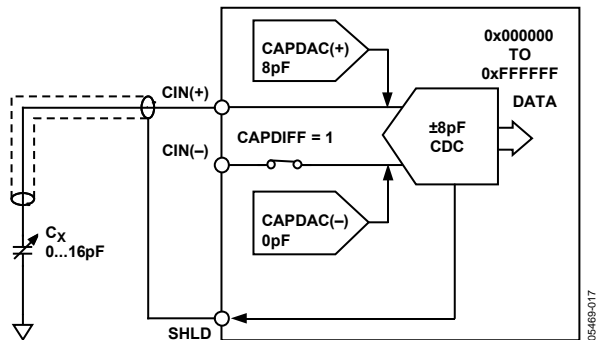

Figure 28. Using CAPDAC in Single-Ended Configuration

Figure 29 shows how to shift the input range further, up to 25 pF absolute value of capacitance connected to the CIN(+).

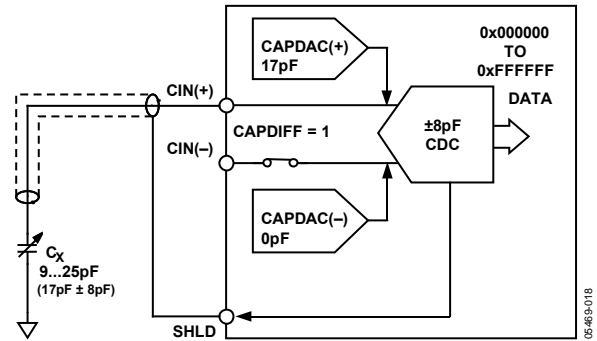

Figure 29. Using CAPDAC in Single-Ended Configuration

DIFFERENTIAL CAPACITIVE CONFIGURATION

When the AD7747 is used for interfacing to a differential capacitive sensor, each of the two input capacitances, C_X and C_Y , must be less than 8 pF (without using the CAPDACs) or must be less than 25 pF and balanced by the CAPDACs. Balancing by the CAPDACs means that both $C_X - CAPDAC(+)$ and $C_Y - CAPDAC(-)$ are less than 8 pF.

If the unbalanced capacitance connected to CIN pins is higher than 8 pF, the CDC introduces a gain error, an offset error, and nonlinearity error.

See the examples shown in Figure 30, Figure 31, and Figure 32.

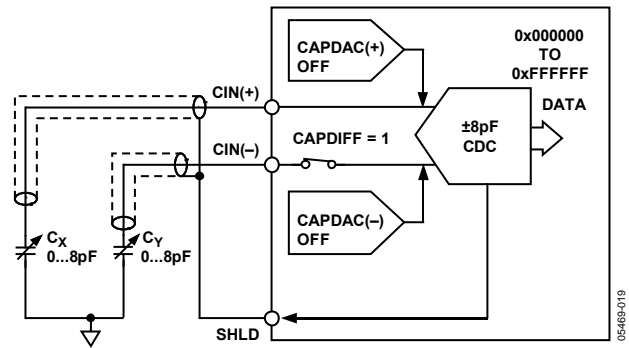

Figure 30. CDC Differential Input Configuration

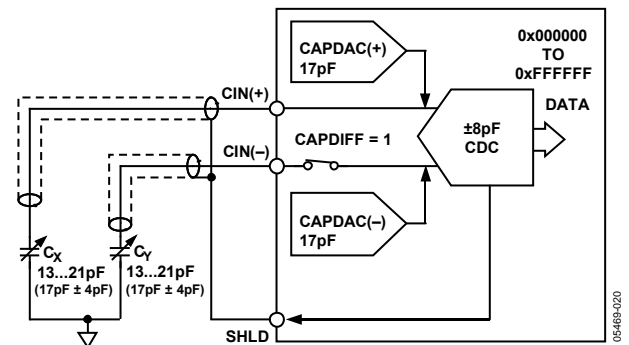

Figure 31. Using CAPDAC in Differential Configuration

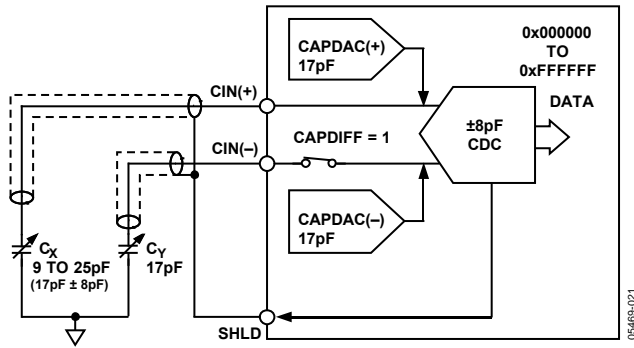

Figure 32. Using CAPDAC in Differential Configuration

PARASITIC CAPACITANCE

The CDC architecture used in the AD7747 measures the capacitance C_X connected between the CIN pin and ground. Most applications use the active shield to avoid external influences during the CDC. However, any parasitic capacitance, C_P , as shown in Figure 33, can affect the CDC result.

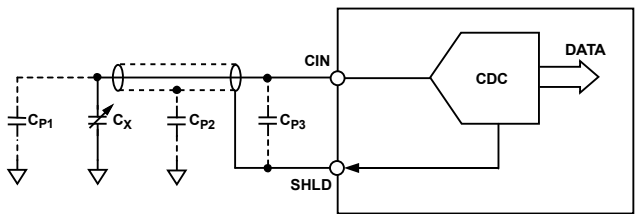

Figure 33. Parasitic Capacitance

A parasitic capacitance, C_{P1} , coupled in between CIN and ground adds directly to the value of the capacitance C_X and, therefore, the CDC result is: $DATA \approx C_X + C_{P1}$. An offset calibration might be sufficient to compensate for a small parasitic capacitance ($C_{P1} \leq 1\text{pF}$). For a larger parasitic capacitance, the CAPDAC can be used to compensate, followed by an offset calibration to ensure the full range of $\pm 8\text{pF}$ is available for the system.

Other parasitic capacitances, such as C_{P2} between active shield and ground as well as C_{P3} between the CIN pin and SHLD, could influence the conversion result. However, the graphs in the Typical Performance Characteristics section show that the effect of parasitic capacitance of type C_{P2}/C_{P3} below 250 pF is insignificant to the CDC result. Figure 7 and Figure 8 show the gain error caused by C_{P2} . Figure 9 shows the gain error caused by C_{P3} .

PARASITIC RESISTANCE

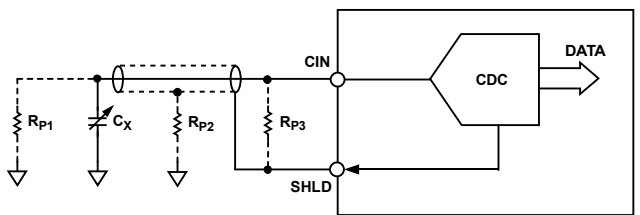

Figure 34. Parasitic Resistance on CIN

Parasitic resistances, as shown in Figure 34, cause leakage currents, which affect the CDC result. The AD7747 CDC measures the charge transfer between the CIN pin and ground. Any resistance connected in parallel to the measured capacitance, C_X , such as the parasitic resistance, R_{P1} , also transfers charge. Therefore, the parallel resistor is seen as an additional capacitance in the output data. A resistance in the range of $R_{P1} \geq 10\text{M}\Omega$ causes an offset error in the CDC result. An offset calibration can be used to compensate for the effect of small leakage currents. A higher leakage current to ground, $R_{P1} \leq 10\text{M}\Omega$, results in a gain error, an offset error, and a nonlinearity error. See Figure 10 in the Typical Performance Characteristics section.

A parasitic resistance, R_{P2} , between SHLD and ground, as well as R_{P3} between the CIN pin and the active shield, as shown in Figure 34, cause a leakage current, which affects the CDC result and is seen as an offset in the data. An offset calibration can be used to compensate for effect of the small leakage current caused by a resistance R_{P2} and $R_{P3} \geq 200\text{k}\Omega$. See Figure 11, Figure 12, and Figure 13 in the Typical Performance Characteristics section.

PARASITIC SERIAL RESISTANCE

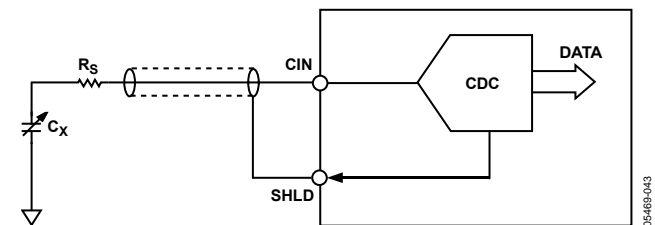

Figure 35. Parasitic Serial Resistance

The AD7747 CDC result is affected by a resistance in series with the measured capacitance. The serial resistance should be less than 10 k Ω for the specified performance. See Figure 14 in the Typical Performance Characteristics section.

CAPACITIVE GAIN CALIBRATION

The AD7747 gain is factory calibrated for the full scale of $\pm 8.192\text{pF}$ in the production for each part individually. The factory gain coefficient is stored in a one-time programmable (OTP) memory and is copied to the capacitive gain register at power-up or after reset.

The gain can be changed by executing a capacitance gain calibration mode, for which an external full-scale capacitance needs to be connected to the capacitance input, or by writing a user value to the capacitive gain register. This change would be only temporary, and the factory gain coefficient would be reloaded back after power-up or reset. The part is tested and specified for use only with the default factory calibration coefficient.

CAPACITIVE SYSTEM OFFSET CALIBRATION

The capacitive offset is dominated by the parasitic offset in the application, such as the initial capacitance of the sensor, any parasitic capacitance of tracks on the board, and the capacitance of any other connections between the sensor and the CDC. Therefore, the AD7747 is not factory calibrated for capacitive offset. It is the user's responsibility to calibrate the system capacitance offset in the application.

Any offset in the capacitance input larger than ± 1 pF should first be removed using the on-chip CAPDACs. The small offset within ± 1 pF can then be removed by using the capacitance offset calibration register.

One method of adjusting the offset is to connect a zero-scale capacitance to the input and execute the capacitance offset calibration mode. The calibration sets the midpoint of the ± 8.192 pF range (that is, Output Code 0x800000) to that zero-scale input.

Another method is to calculate and write the offset calibration register value; the LSB value is 31.25 aF ($8.192 \text{ pF}/2^{17}$).

The offset calibration register is reloaded by the default value at power-on or after reset. Therefore, if the offset calibration is not repeated after each system power-up, the calibration coefficient value should be stored by the host controller and reloaded as part of the AD7747 setup.

INTERNAL TEMPERATURE SENSOR

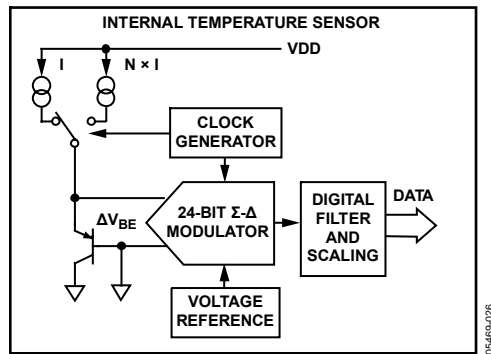

Figure 36. Internal Temperature Sensor

The temperature sensing method used in the AD7747 is to measure a difference in ΔV_{BE} voltage of a transistor operated at two different currents (see Figure 36). The ΔV_{BE} change with temperature is linear and can be expressed as

$$\Delta V_{BE} = (n_f) \frac{KT}{q} \times \ln(N)$$

where:

K is Boltzmann's constant (1.38×10^{-23}).

T is the absolute temperature in Kelvin.

q is the charge on the electron (1.6×10^{-19} coulombs).

N is the ratio of the two currents.

n_f is the ideality factor of the thermal diode.

The AD7747 uses an on-chip transistor to measure the temperature of the silicon chip inside the package. The Σ - Δ ADC converts the ΔV_{BE} to digital; the data are scaled using factory calibration coefficients. Thus, the output code is proportional to temperature.

$$\text{Temperature}(\text{°C}) = \frac{\text{Code}}{2048} - 4096$$

The AD7747 has a low power consumption resulting in only a small effect due to the part self-heating (less than 0.5°C at $V_{DD} = 5 \text{ V}$).

If the capacitive sensor can be considered to be at the same temperature as the AD7747 chip, the internal temperature sensor can be used as a system temperature sensor. That means the complete system temperature drift compensation can be based on the AD7747 internal temperature sensor without need for any additional external components. See Figure 17 in the Typical Performance Characteristics section.

EXTERNAL TEMPERATURE SENSOR

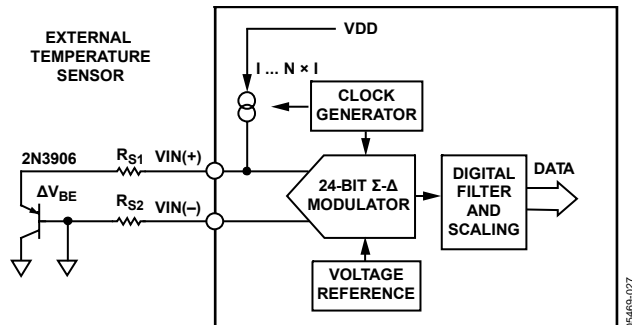

Figure 37. Transistor as an External Temperature Sensor

The AD7747 provides the option of using an external transistor as a temperature sensor in the system. The ΔV_{BE} method, which is similar to the internal temperature sensor method, is used. However, it is modified to compensate for the serial resistance of connections to the sensor. Total serial resistance ($R_{S1} + R_{S2}$ in Figure 37) up to 100Ω is compensated. The $VIN(-)$ pin must be grounded for proper external temperature sensor operation.

The AD7747 is factory calibrated for Transistor 2N3906 with the ideality factor $n_f = 1.008$.

See Figure 18 in the Typical Performance Characteristics section.

VOLTAGE INPUT

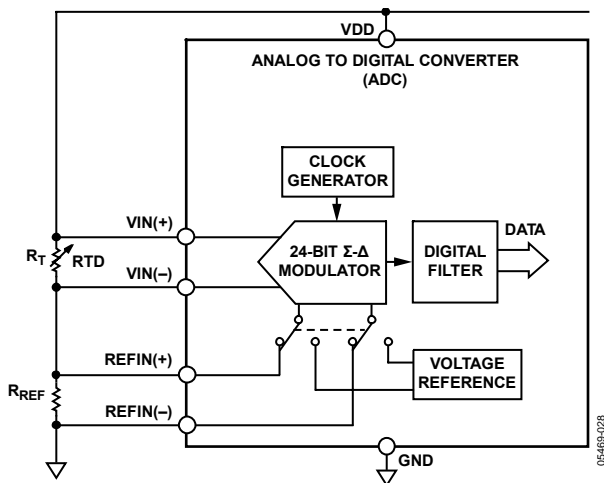

Figure 38. Resistive Temperature Sensor Connected to the Voltage Input

The AD7747 Σ - Δ core can work as a high resolution (up to 21 ENOB) classic ADC with a fully differential voltage input. The ADC can be used either with the on-chip high precision, low drift, 1.17 V voltage reference, or with an external reference connected to the fully differential reference input pins.

The voltage and reference inputs are continuously sampled by a Σ - Δ modulator during the conversion. Therefore, the input source impedance should be kept low. See the application example in Figure 38.

V_{DD} MONITOR

Along with converting external voltages, the AD7747 Σ - Δ ADC can be used for monitoring the V_{DD} voltage. The voltage from the VDD pin is internally attenuated by 6.

AD7747

TYPICAL APPLICATION DIAGRAM

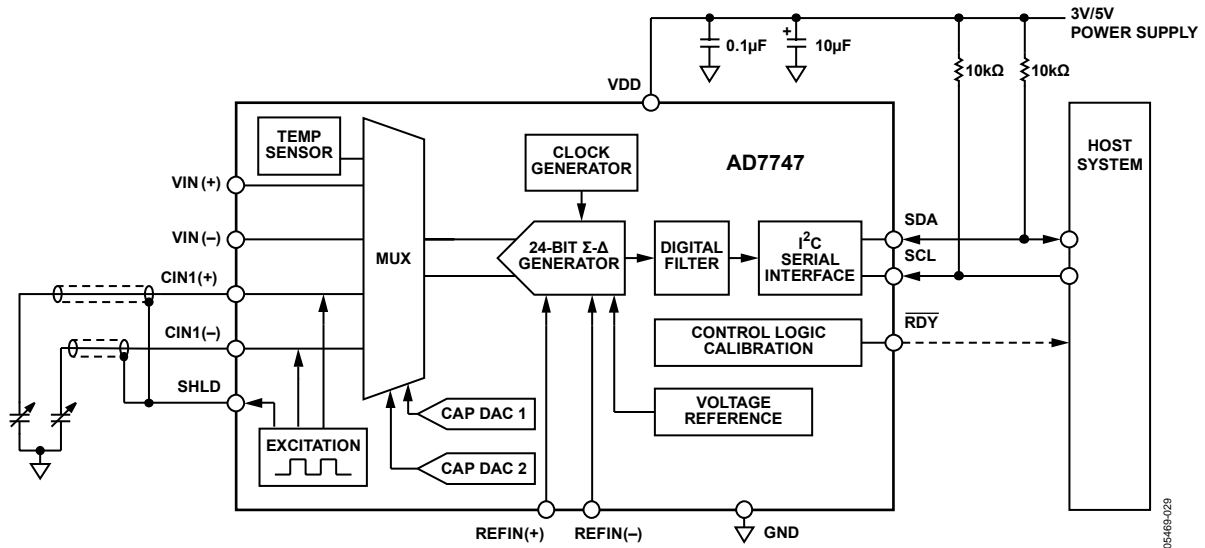
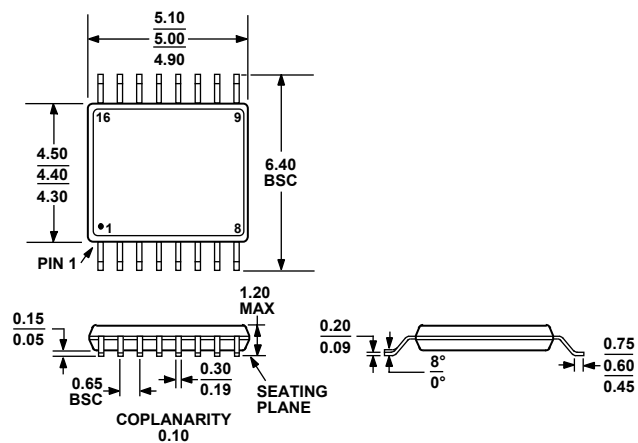

Figure 39. Basic Application Diagram for a Differential Capacitive Sensor

05F469-029

OUTLINE DIMENSIONS



COMPLIANT TO JEDEC STANDARDS MO-153-AB

Figure 40. 16-Lead Thin Shrink Small Outline Package [TSSOP]
(RU-16)

Dimensions shown in millimeters

ORDERING GUIDE

Model	Temperature Range	Package Description	Package Option
AD7747ARUZ ¹	−40°C to +125°C	16-Lead TSSOP	RU-16
AD7747ARUZ-REEL ¹	−40°C to +125°C	16-Lead TSSOP	RU-16
AD7747ARUZ-REEL7 ¹	−40°C to +125°C	16-Lead TSSOP	RU-16
EVAL-AD7747EBZ ¹		Evaluation Board	

¹ Z = Pb-free part.

AD7747

NOTES

Purchase of licensed I²C components of Analog Devices or one of its sublicensed Associated Companies conveys a license for the purchaser under the Philips I²C Patent Rights to use these components in an I²C system, provided that the system conforms to the I²C Standard Specification as defined by Philips.

©2007 Analog Devices, Inc. All rights reserved. Trademarks and registered trademarks are the property of their respective owners.
D05469-0-1/07(0)



www.analog.com

Rev. 0 | Page 28 of 28