

PIN CONFIGURATIONS

44-Pin SOJ (K)

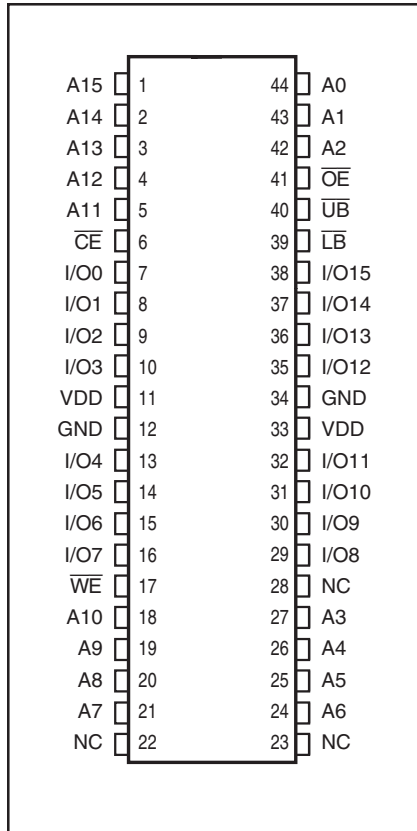

44-Pin TSOP-II (T)

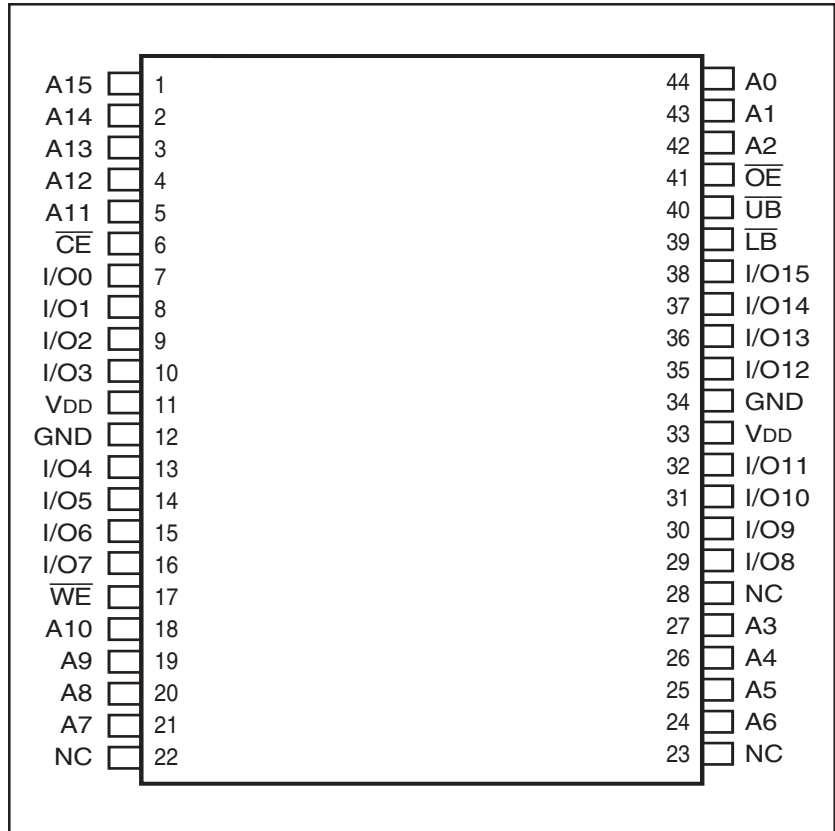

48-Pin mini BGA (6mm x 8mm) (B)

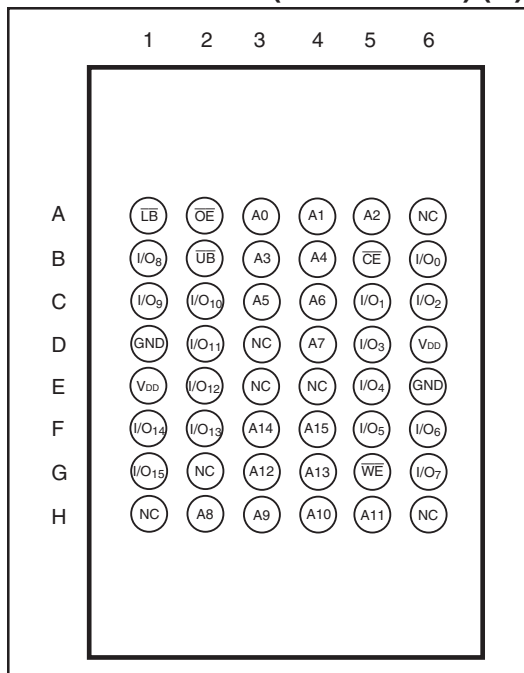

PIN DESCRIPTIONS

A0-A15	Address Inputs
I/O0-I/O15	Data Inputs/Outputs
$\overline{CE}$	Chip Enable Input
$\overline{OE}$	Output Enable Input
$\overline{WE}$	Write Enable Input
$\overline{LB}$	Lower-byte Control (I/O0-I/O7)
$\overline{UB}$	Upper-byte Control (I/O8-I/O15)
NC	No Connection
VDD	Power
GND	Ground

TRUTH TABLE

Mode	$\overline{WE}$	$\overline{CE}$	$\overline{OE}$	$\overline{LB}$	$\overline{UB}$	I/O PIN		$V_{DD}$ Current
						I/O0-I/O7	I/O8-I/O15	
Not Selected	X	H	X	X	X	High-Z	High-Z	$I_{SB1}$ , $I_{SB2}$
Output Disabled	H	L	H	X	X	High-Z	High-Z	$I_{CC}$
	X	L	X	H	H	High-Z	High-Z	
Read	H	L	L	L	H	DOUT	High-Z	$I_{CC}$
	H	L	L	H	L	High-Z	DOUT	
	H	L	L	L	L	DOUT	DOUT	
Write	L	L	X	L	H	DIN	High-Z	$I_{CC}$
	L	L	X	H	L	High-Z	DIN	
	L	L	X	L	L	DIN	DIN	

ABSOLUTE MAXIMUM RATINGS<sup>(1)</sup>

Symbol	Parameter	Value	Unit
$V_{TERM}$	Terminal Voltage with Respect to GND	-0.5 to $V_{DD}+0.5$	V
$T_{STG}$	Storage Temperature	-65 to +150	°C
$P_T$	Power Dissipation	1.5	W
$I_{OUT}$	DC Output Current (LOW)	20	mA

Note:

1. Stress greater than those listed under ABSOLUTE MAXIMUM RATINGS may cause permanent damage to the device. This is a stress rating only and functional operation of the device at these or any other conditions above those indicated in the operational sections of this specification is not implied. Exposure to absolute maximum rating conditions for extended periods may affect reliability.

OPERATING RANGE

Range	Ambient Temperature	$V_{DD}$ (8,10 ns)	$V_{DD}$ (12 ns)
Commercial	0°C to +70°C	3.3V+10%,-5%	3.3V ± 10%
Industrial	-40°C to +85°C	3.3V+10%,-5%	3.3V ± 10%

DC ELECTRICAL CHARACTERISTICS (Over Operating Range)

Symbol	Parameter	Test Conditions	Min.	Max.	Unit
$V_{OH}$	Output HIGH Voltage	$V_{DD} = \text{Min.}, I_{OH} = -4.0 \text{ mA}$	2.4	—	V
$V_{OL}$	Output LOW Voltage	$V_{DD} = \text{Min.}, I_{OL} = 8.0 \text{ mA}$	—	0.4	V
$V_{IH}$	Input HIGH Voltage		2	$V_{DD} + 0.3$	V
$V_{IL}$	Input LOW Voltage <sup>(1)</sup>		-0.3	0.8	V
$I_{LI}$	Input Leakage	$GND \leq V_{IN} \leq V_{DD}$	-2	2	μA
$I_{LO}$	Output Leakage	$GND \leq V_{OUT} \leq V_{DD}$ , Outputs Disabled	-2	2	μA

Notes:

1.  $V_{IL}$  (min.) = -2.0V for pulse width less than 10 ns.

IS61LV6416

POWER SUPPLY CHARACTERISTICS<sup>(1)</sup> (Over Operating Range)

Symbol	Parameter	Test Conditions		-8 ns		-10 ns		-12 ns		Unit
				Min.	Max.	Min.	Max.	Min.	Max.	
I <sub>CC</sub>	V <sub>DD</sub> Dynamic Operating Supply Current	V <sub>DD</sub> = Max., I <sub>OUT</sub> = 0 mA, f = f <sub>MAX</sub>	Com.	—	140	—	120	—	100	mA
			Ind.	—	150	—	130	—	110	
			typ. <sup>(2)</sup>	—	105	—	95	—	75	
I <sub>SB1</sub>	TTL Standby Current (TTL Inputs)	V <sub>DD</sub> = Max., V <sub>IN</sub> = V <sub>IH</sub> or V <sub>IL</sub> CE ≥ V <sub>IH</sub> , f = 0	Com.	—	15	—	15	—	15	mA
			Ind.	—	20	—	20	—	20	
I <sub>SB2</sub>	CMOS Standby Current (CMOS Inputs)	V <sub>DD</sub> = Max., CE ≥ V <sub>DD</sub> - 0.2V, V <sub>IN</sub> ≥ V <sub>DD</sub> - 0.2V, or V <sub>IN</sub> ≤ 0.2V, f = 0	Com.	—	5	—	5	—	5	mA
			Ind.	—	10	—	10	—	10	
			typ. <sup>(2)</sup>	—	0.5	—	0.5	—	0.5	

Note:

- At f = f<sub>MAX</sub>, address and data inputs are cycling at the maximum frequency, f = 0 means no input lines change.
- Typical values are measured at V<sub>DD</sub>=3.3V, T<sub>A</sub>=25°C. Not 100% Tested.

IS61LV6416L

POWER SUPPLY CHARACTERISTICS<sup>(1)</sup> (Over Operating Range)

Symbol	Parameter	Test Conditions		-8 ns		-10 ns		Unit
				Min.	Max.	Min.	Max.	
I <sub>CC</sub>	V <sub>DD</sub> Dynamic Operating Supply Current	V <sub>DD</sub> = Max., I <sub>OUT</sub> = 0 mA, f = f <sub>MAX</sub>	Com.	—	100	—	95	mA
			Ind.	—	110	—	105	
			typ. <sup>(2)</sup>	—	75	—	70	
I <sub>SB1</sub>	TTL Standby Current (TTL Inputs)	V <sub>DD</sub> = Max., V <sub>IN</sub> = V <sub>IH</sub> or V <sub>IL</sub> CE ≥ V <sub>IH</sub> , f = 0	Com.	—	15	—	15	mA
			Ind.	—	20	—	20	
I <sub>SB2</sub>	CMOS Standby Current (CMOS Inputs)	V <sub>DD</sub> = Max., CE ≥ V <sub>DD</sub> - 0.2V, V <sub>IN</sub> ≥ V <sub>DD</sub> - 0.2V, or V <sub>IN</sub> ≤ 0.2V, f = 0	Com.	—	1	—	1	mA
			Ind.	—	1.5	—	1.5	
			typ. <sup>(2)</sup>	—	0.05	—	0.05	

Note:

- At f = f<sub>MAX</sub>, address and data inputs are cycling at the maximum frequency, f = 0 means no input lines change.
- Typical values are measured at V<sub>DD</sub>=3.3V, T<sub>A</sub>=25°C. Not 100% Tested.

CAPACITANCE<sup>(1)</sup>

Symbol	Parameter	Conditions	Max.	Unit
C <sub>IN</sub>	Input Capacitance	V <sub>IN</sub> = 0V	6	pF
C <sub>OUT</sub>	Input/Output Capacitance	V <sub>OUT</sub> = 0V	8	pF

Note:

- Tested initially and after any design or process changes that may affect these parameters.

## AC TEST CONDITIONS

Parameter	Unit
Input Pulse Level	0V to 3.0V
Input Rise and Fall Times	3 ns
Input and Output Timing and Reference Level	1.5V
Output Load	See Figures 1a and 1b

## AC TEST LOADS

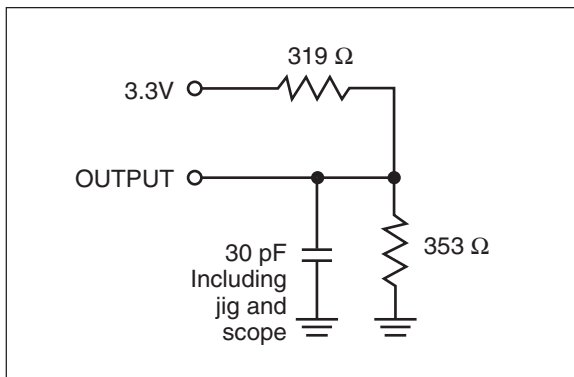

Figure 1a.

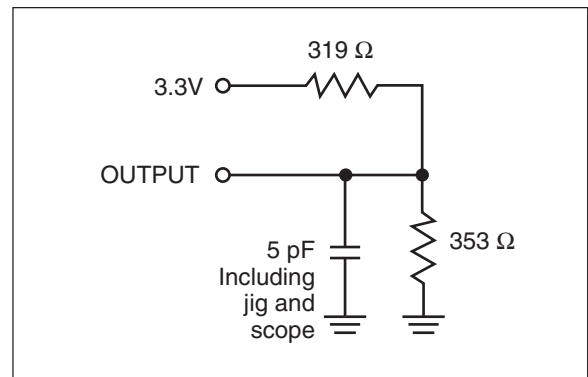

Figure 1b.

## READ CYCLE SWITCHING CHARACTERISTICS<sup>(1)</sup> (Over Operating Range)

Symbol	Parameter	-8 ns		-10 ns		-12 ns		Unit
		Min.	Max.	Min.	Max.	Min.	Max.	
$t_{RC}$	Read Cycle Time	8	—	10	—	12	—	ns
$t_{AA}$	Address Access Time	—	8	—	10	—	12	ns
$t_{OHA}$	Output Hold Time	3	—	3	—	3	—	ns
$t_{ACE}$	$\overline{CE}$ Access Time	—	8	—	10	—	12	ns
$t_{DOE}$	$\overline{OE}$ Access Time	—	5	—	5	—	6	ns
$t_{HZOE}^{(2)}$	$\overline{OE}$ to High-Z Output	—	5	—	5	—	6	ns
$t_{LZOE}^{(2)}$	$\overline{OE}$ to Low-Z Output	0	—	0	—	0	—	ns
$t_{HZCE}^{(2)}$	$\overline{CE}$ to High-Z Output	0	4	0	5	0	6	ns
$t_{LZCE}^{(2)}$	$\overline{CE}$ to Low-Z Output	3	—	3	—	3	—	ns
$t_{BA}$	$\overline{LB}, \overline{UB}$ Access Time	—	6	—	6	—	6	ns
$t_{HZB}$	$\overline{LB}, \overline{UB}$ to High-Z Output	0	4	0	5	0	6	ns
$t_{LZB}$	$\overline{LB}, \overline{UB}$ to Low-Z Output	0	—	0	—	0	—	ns

### Notes:

1. Test conditions assume signal transition times of 3 ns or less, timing reference levels of 1.5V, input pulse levels of 0 to 3.0V and output loading specified in Figure 1a.
2. Tested with the load in Figure 1b. Transition is measured  $\pm 500$  mV from steady-state voltage. Not 100% tested.
3. Not 100% tested.

AC WAVEFORMS

READ CYCLE NO. 1<sup>(1,2)</sup> (Address Controlled) ( $\overline{CS} = \overline{OE} = V_{IL}$ ,  $\overline{UB}$  or  $\overline{LB} = V_{IL}$ )

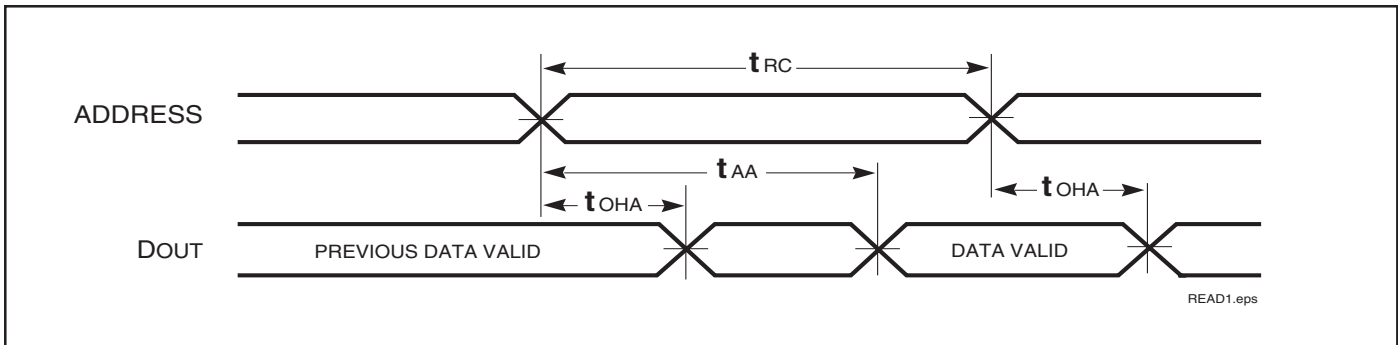

READ CYCLE NO. 2<sup>(1,3)</sup>

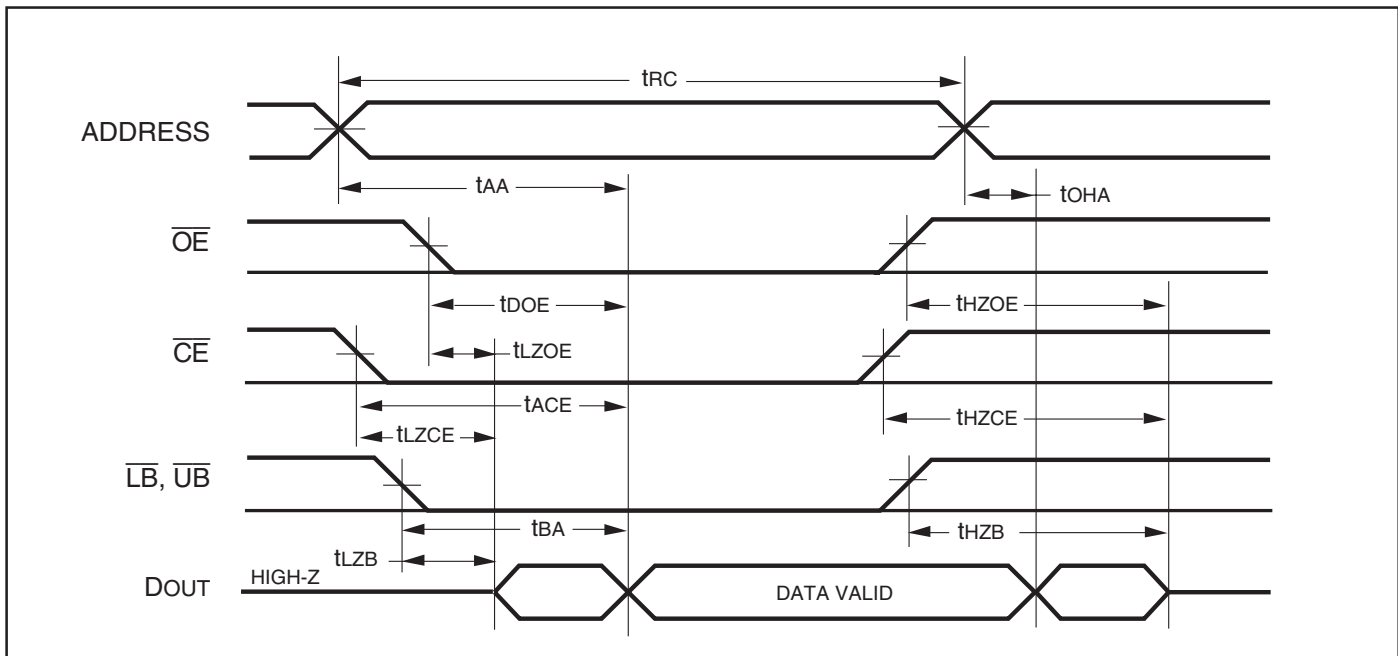

Notes:

1.  $\overline{WE}$  is HIGH for a Read Cycle.
2. The device is continuously selected.  $\overline{OE}$ ,  $\overline{CE}$ ,  $\overline{UB}$ , or  $\overline{LB} = V_{IL}$ .
3. Address is valid prior to or coincident with  $\overline{CE}$  LOW transition.

**WRITE CYCLE SWITCHING CHARACTERISTICS<sup>(1,3)</sup>** (Over Operating Range)

Symbol	Parameter	-8 ns		-10 ns		-12 ns		Unit
		Min.	Max.	Min.	Max.	Min.	Max.	
t <sub>WC</sub>	Write Cycle Time	8	—	10	—	12	—	ns
t <sub>SCE</sub>	$\overline{CE}$ to Write End	6	—	8	—	9	—	ns
t <sub>AW</sub>	Address Setup Time to Write End	8	—	8	—	9	—	ns
t <sub>HA</sub>	Address Hold from Write End	0	—	0	—	0	—	ns
t <sub>SA</sub>	Address Setup Time	0	—	0	—	0	—	ns
t <sub>PBW</sub>	$\overline{LB}$ , $\overline{UB}$ Valid to End of Write	7	—	8	—	9	—	ns
t <sub>PWE1</sub> /t <sub>PWE2</sub>	$\overline{WE}$ Pulse Width ( $\overline{OE}$ = HIGH/LOW)	6	—	8	—	9	—	ns
t <sub>SD</sub>	Data Setup to Write End	6	—	6	—	6	—	ns
t <sub>HD</sub>	Data Hold from Write End	0	—	0	—	0	—	ns
t <sub>HZWE<sup>(2)</sup></sub>	$\overline{WE}$ LOW to High-Z Output	—	4	—	5	—	6	ns
t <sub>LZWE<sup>(2)</sup></sub>	$\overline{WE}$ HIGH to Low-Z Output	3	—	3	—	3	—	ns

**Notes:**

1. Test conditions assume signal transition times of 3 ns or less, timing reference levels of 1.5V, input pulse levels of 0 to 3.0V and output loading specified in Figure 1a.
2. Tested with the load in Figure 1b. Transition is measured  $\pm 500$  mV from steady-state voltage. Not 100% tested.
3. The internal write time is defined by the overlap of  $\overline{CE}$  LOW and  $\overline{UB}$  or  $\overline{LB}$ , and  $\overline{WE}$  LOW. All signals must be in valid states to initiate a Write, but any one can go inactive to terminate the Write. The Data Input Setup and Hold timing are referenced to the rising or falling edge of the signal that terminates the write.

WRITE CYCLE NO. 1<sup>(1,2)</sup> ( $\overline{CE}$  Controlled,  $\overline{OE}$  = HIGH or LOW)

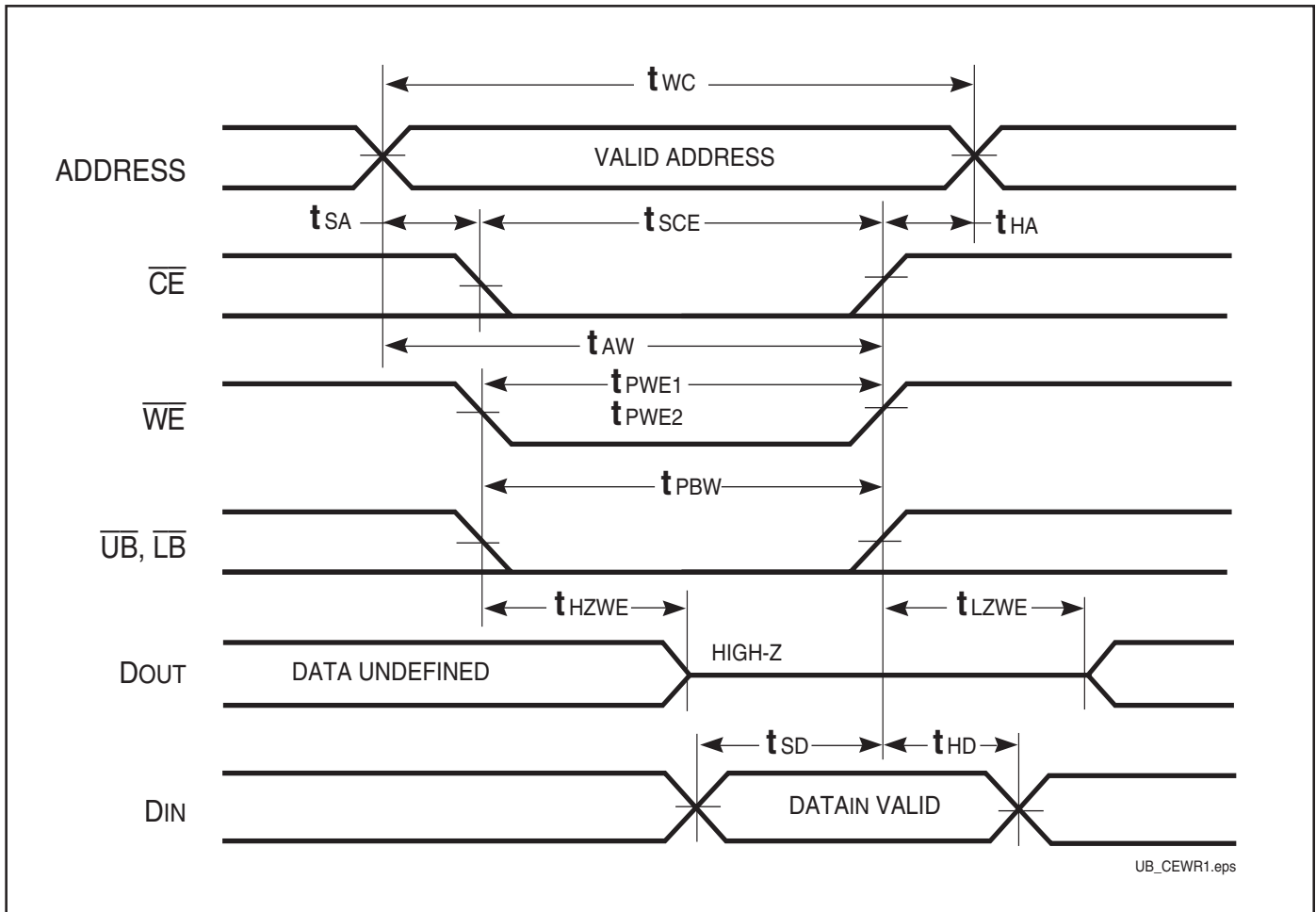

**WRITE CYCLE NO. 2<sup>(1)</sup>** ( $\overline{WE}$  Controlled,  $\overline{OE}$  = HIGH during Write Cycle)

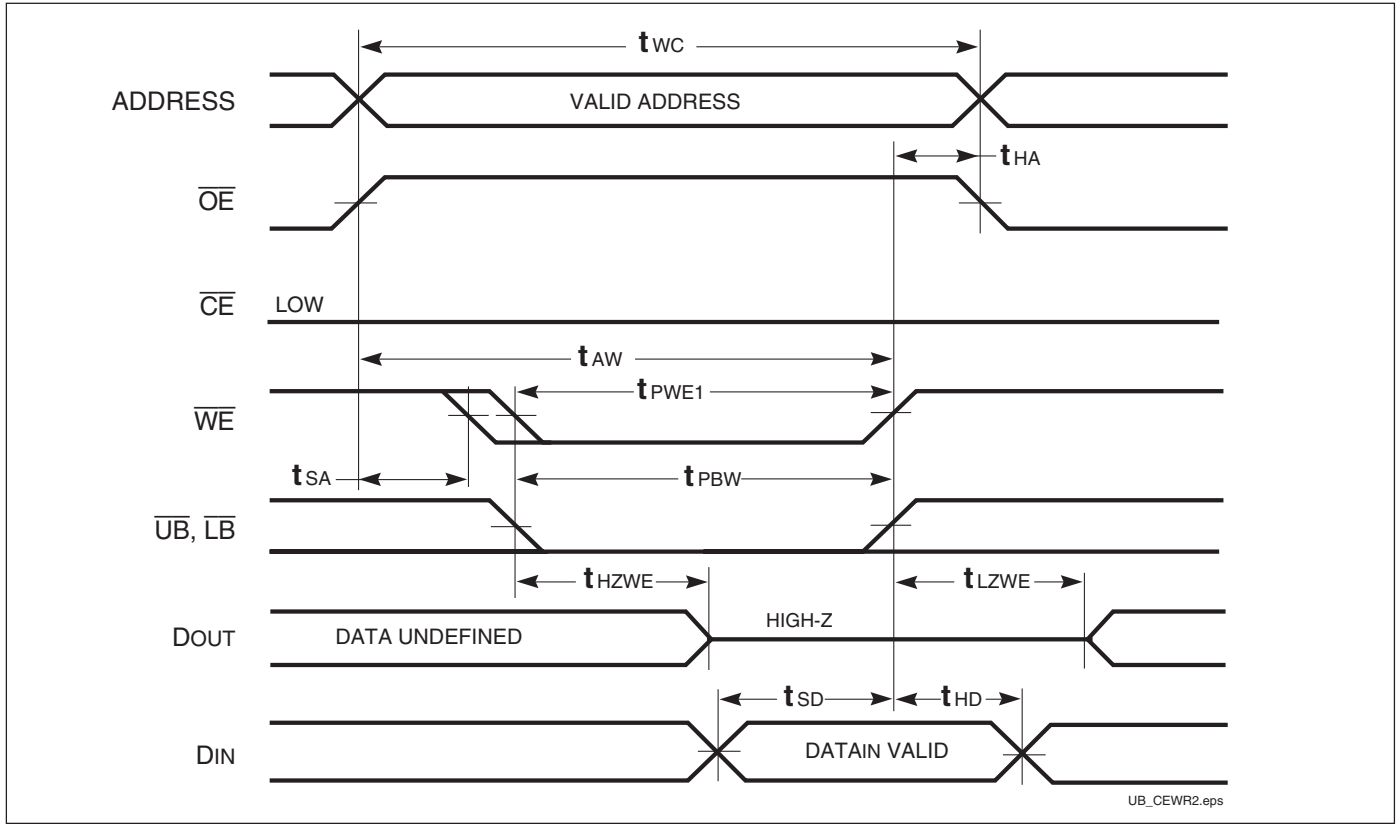

**WRITE CYCLE NO. 3** ( $\overline{WE}$  Controlled:  $\overline{OE}$  is LOW During Write Cycle)

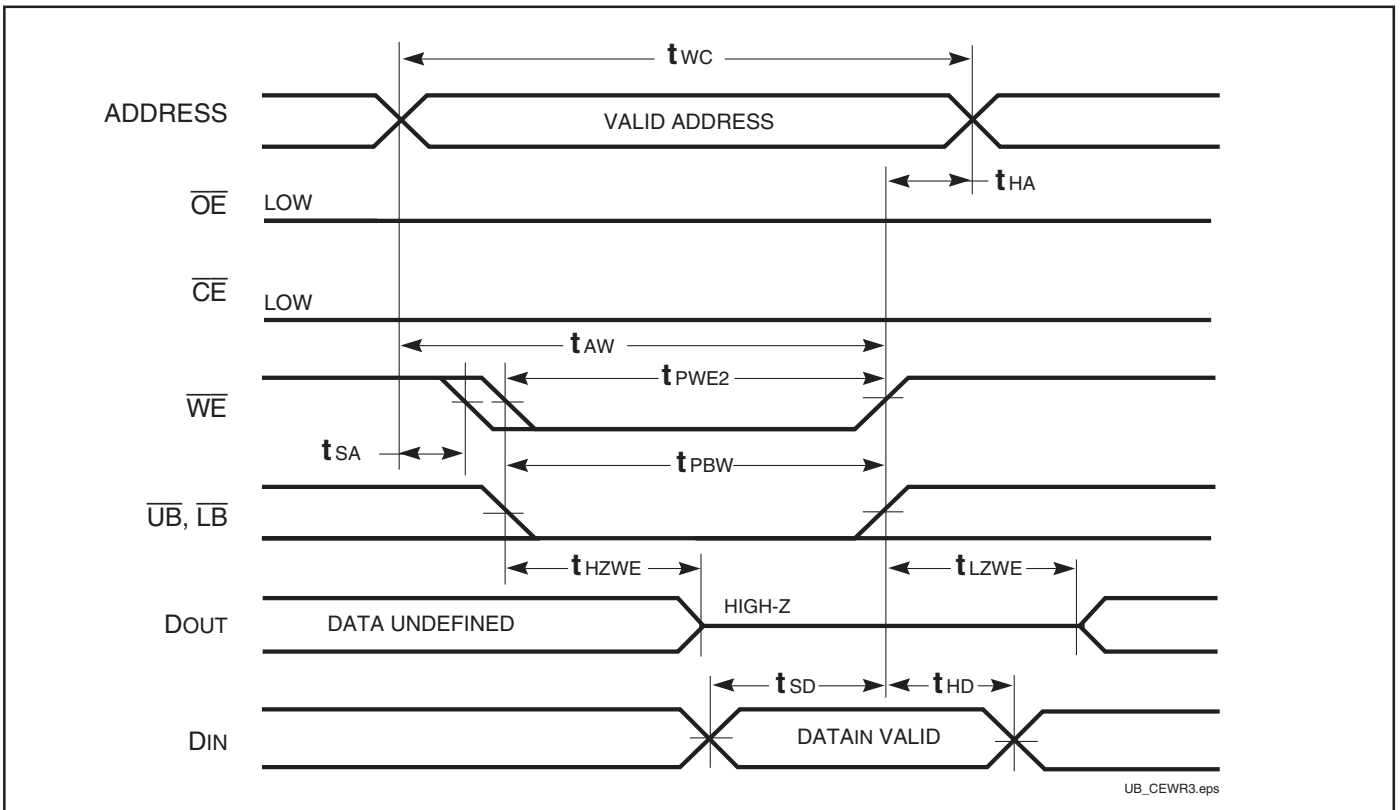



WRITE CYCLE NO. 4 ( $\overline{\text{LB}}$ ,  $\overline{\text{UB}}$  Controlled, Back-to-Back Write)<sup>(1,3)</sup>

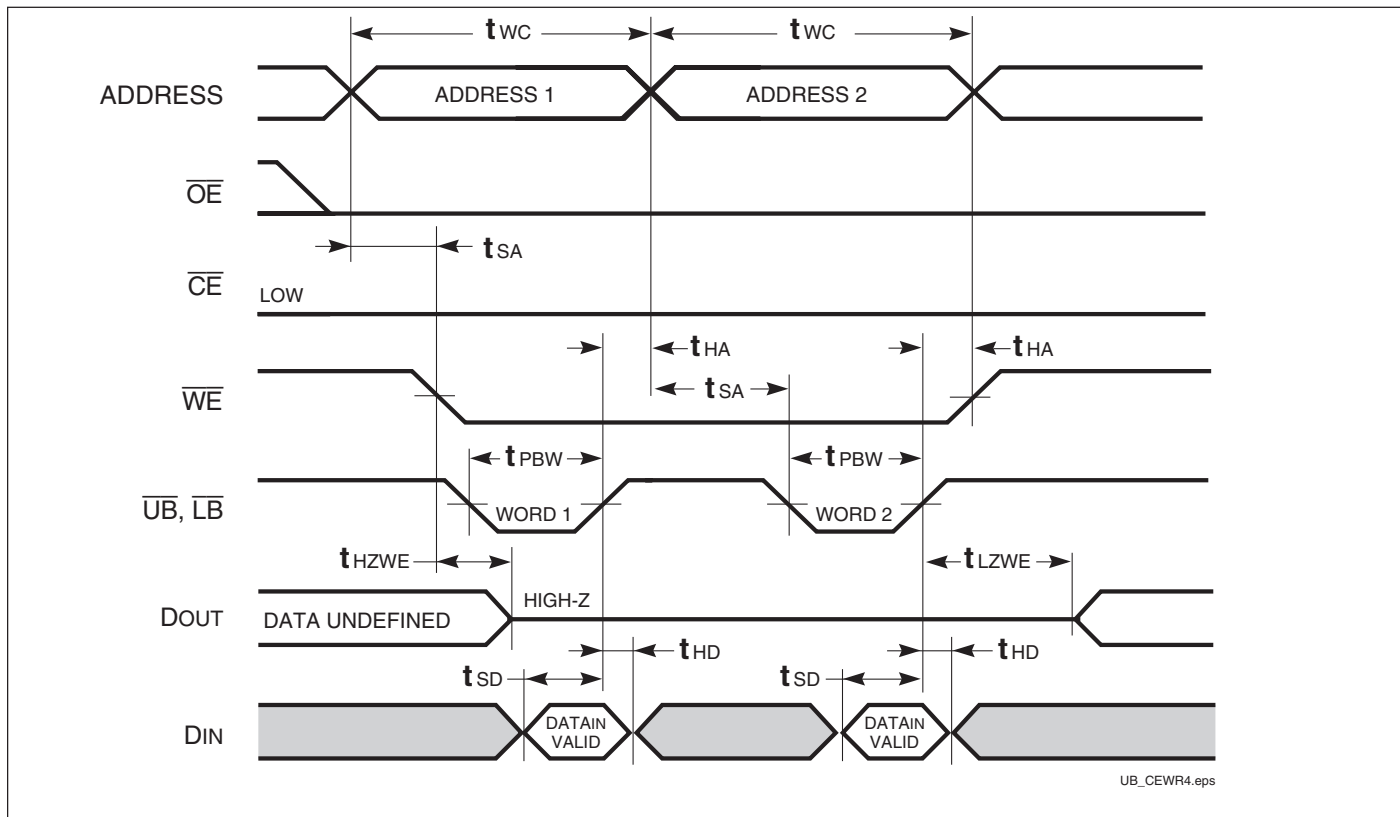

Notes:

1. The internal Write time is defined by the overlap of  $\overline{\text{CE}} = \text{LOW}$ ,  $\overline{\text{UB}}$  and/or  $\overline{\text{LB}} = \text{LOW}$ , and  $\overline{\text{WE}} = \text{LOW}$ . All signals must be in valid states to initiate a Write, but any can be deasserted to terminate the Write. The  $t_{\text{SA}}$ ,  $t_{\text{HA}}$ ,  $t_{\text{SD}}$ , and  $t_{\text{HD}}$  timing is referenced to the rising or falling edge of the signal that terminates the Write.
2. Tested with  $\overline{\text{OE}}$  HIGH for a minimum of 4 ns before  $\overline{\text{WE}} = \text{LOW}$  to place the I/O in a HIGH-Z state.
3.  $\overline{\text{WE}}$  may be held LOW across many address cycles and the  $\overline{\text{LB}}$ ,  $\overline{\text{UB}}$  pins can be used to control the Write function.

**DATA RETENTION SWITCHING CHARACTERISTICS**

Symbol	Parameter	Test Condition	Options	Min.	Typ. <sup>(1)</sup>	Max.	Unit
V <sub>DR</sub>	V <sub>DD</sub> for Data Retention	See Data Retention Waveform		2.0	—	3.6	V
I <sub>DR</sub>	Data Retention Current	V <sub>DD</sub> = 2.0V, $\overline{CE} \geq V_{DD} - 0.2V$	IS61LV6416 IS61LV6416L	—	0.5 0.05	10 1.5	mA
t <sub>SDR</sub>	Data Retention Setup Time	See Data Retention Waveform		0	—	—	ns
t <sub>RDR</sub>	Recovery Time	See Data Retention Waveform		t <sub>rc</sub>	—	—	ns

**Note 1:** Typical values are measured at V<sub>DD</sub> = 3.0V, T<sub>A</sub> = 25°C and not 100% tested.

**DATA RETENTION WAVEFORM ( $\overline{CE}$  Controlled)**

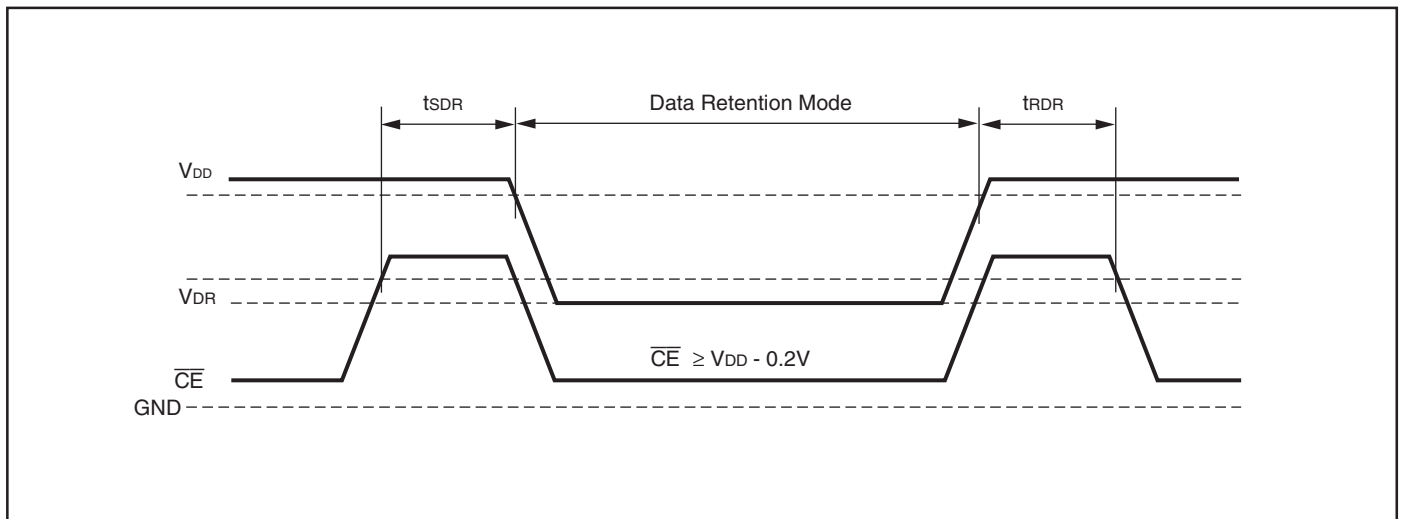

IS61LV6416

ORDERING INFORMATION

Speed (ns)	Order Part No.	Package	Temperature Range
8	IS61LV6416-8T	Plastic TSOP	Commercial (0°C to +70°C)
8	IS61LV6416-8TL	Plastic TSOP	Commercial (0°C to +70°C), Lead-free
8	IS61LV6416-8BI	mini BGA (6mm x 8mm)	Industrial (-40°C to +85°C)
8	IS61LV6416-8TI	Plastic TSOP	Industrial (-40°C to +85°C)
8	IS61LV6416-8KL	400-mil Plastic SOJ	Commercial (0°C to +70°C), Lead-free
10	IS61LV6416-10T	Plastic TSOP	Commercial (0°C to +70°C)
10	IS61LV6416-10TL	Plastic TSOP	Commercial (0°C to +70°C), Lead-free
10	IS61LV6416-10K	400-mil Plastic SOJ	Commercial (0°C to +70°C)
10	IS61LV6416-10BI	mini BGA (6mm x 8mm)	Industrial (-40°C to +85°C)
10	IS61LV6416-10BLI	mini BGA (6mm x 8mm)	Industrial (-40°C to +85°C), Lead-free
10	IS61LV6416-10TI	Plastic TSOP	Industrial (-40°C to +85°C)
10	IS61LV6416-10TLI	Plastic TSOP	Industrial (-40°C to +85°C), Lead-free
10	IS61LV6416-10KI	400-mil Plastic SOJ	Industrial (-40°C to +85°C)
10	IS61LV6416-10KLI	400-mil Plastic SOJ	Industrial (-40°C to +85°C), Lead-free
12	IS61LV6416-12T	Plastic TSOP	Commercial (0°C to +70°C)
12	IS61LV6416-12K	400-mil Plastic SOJ	Commercial (0°C to +70°C)
12	IS61LV6416-12KL	400-mil Plastic SOJ	Commercial (0°C to +70°C), Lead-free
12	IS61LV6416-12BI	mini BGA (6mm x 8mm)	Industrial (-40°C to +85°C)

IS61LV6416L

ORDERING INFORMATION

Speed (ns)	Order Part No.	Package	Temperature Range
8	IS61LV6416L-8T	Plastic TSOP	Commercial (0°C to +70°C)
8	IS61LV6416L-8BI	mini BGA (6mm x 8mm)	Industrial (-40°C to +85°C)
8	IS61LV6416L-8TI	Plastic TSOP	Industrial (-40°C to +85°C)
8	IS61LV6416L-8KI	400-mil Plastic SOJ	Industrial (-40°C to +85°C)
10	IS61LV6416L-10T	Plastic TSOP	Commercial (0°C to +70°C)
10	IS61LV6416L-10BI	mini BGA (6mm x 8mm)	Industrial (-40°C to +85°C)
10	IS61LV6416L-10TI	Plastic TSOP	Industrial (-40°C to +85°C)
10	IS61LV6416L-10KI	400-mil Plastic SOJ	Industrial (-40°C to +85°C)

# PACKAGING INFORMATION

400-mil Plastic SOJ

Package Code: K

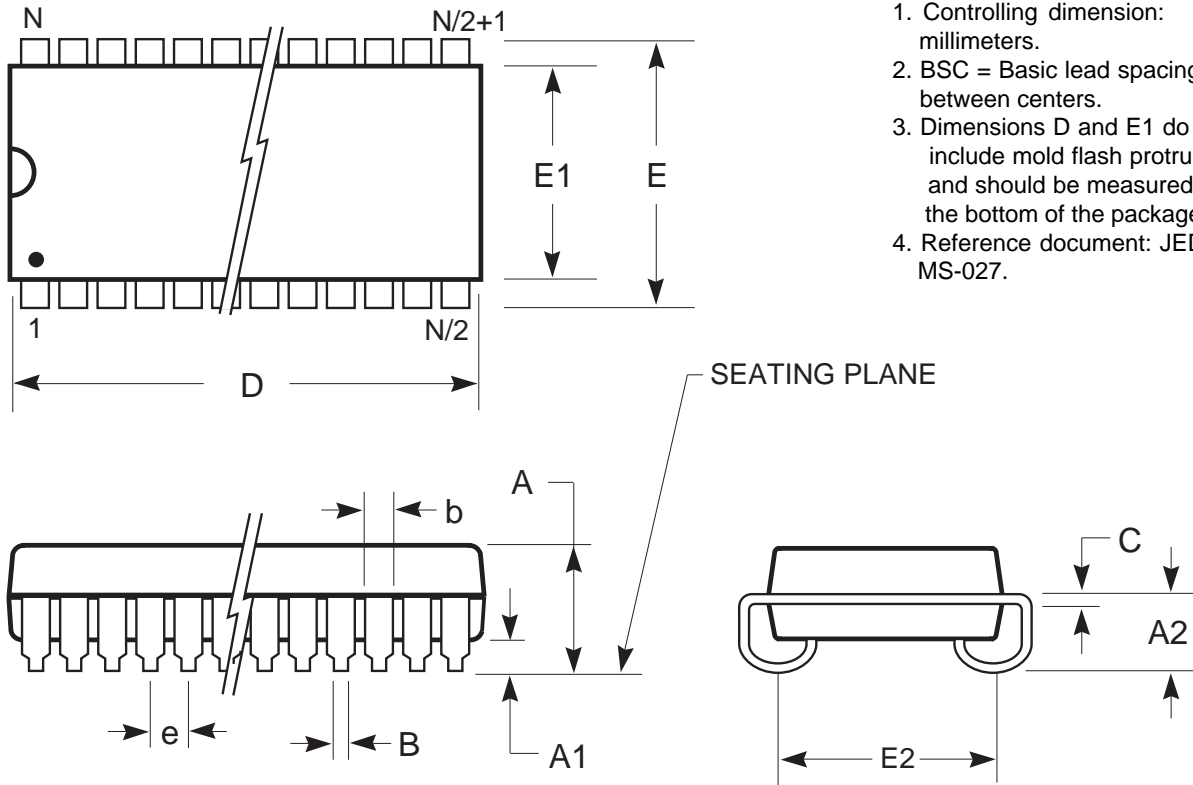

**Notes:**

1. Controlling dimension: millimeters.
2. BSC = Basic lead spacing between centers.
3. Dimensions D and E1 do not include mold flash protrusions and should be measured from the bottom of the package.
4. Reference document: JEDEC MS-027.

Symbol	Millimeters		Inches		Millimeters		Inches		Millimeters		Inches	
	Min	Max	Min	Max	Min	Max	Min	Max	Min	Max	Min	Max
No. Leads (N)	28				32				36			
A	3.25	3.75	0.128	0.148	3.25	3.75	0.128	0.148	3.25	3.75	0.128	0.148
A1	0.64	—	0.025	—	0.64	—	0.025	—	0.64	—	0.025	—
A2	2.08	—	0.082	—	2.08	—	0.082	—	2.08	—	0.082	—
B	0.38	0.51	0.015	0.020	0.38	0.51	0.015	0.020	0.38	0.51	0.015	0.020
b	0.66	0.81	0.026	0.032	0.66	0.81	0.026	0.032	0.66	0.81	0.026	0.032
C	0.18	0.33	0.007	0.013	0.18	0.33	0.007	0.013	0.18	0.33	0.007	0.013
D	18.29	18.54	0.720	0.730	20.82	21.08	0.820	0.830	23.37	23.62	0.920	0.930
E	11.05	11.30	0.435	0.445	11.05	11.30	0.435	0.445	11.05	11.30	0.435	0.445
E1	10.03	10.29	0.395	0.405	10.03	10.29	0.395	0.405	10.03	10.29	0.395	0.405
E2	9.40 BSC		0.370 BSC		9.40 BSC		0.370 BSC		9.40 BSC		0.370 BSC	
e	1.27 BSC		0.050 BSC		1.27 BSC		0.050 BSC		1.27 BSC		0.050 BSC	

Copyright © 2003 Integrated Silicon Solution, Inc. All rights reserved. ISSI reserves the right to make changes to this specification and its products at any time without notice. ISSI assumes no liability arising out of the application or use of any information, products or services described herein. Customers are advised to obtain the latest version of this device specification before relying on any published information and before placing orders for products.

**Integrated Silicon Solution, Inc. — [www.issi.com](http://www.issi.com) — 1-800-379-4774**

Rev. F  
10/29/03

Symbol	Millimeters		Inches		Millimeters		Inches		Millimeters		Inches	
	Min	Max	Min	Max	Min	Max	Min	Max	Min	Max	Min	Max
No. Leads (N)	<b>40</b>				<b>42</b>				<b>44</b>			
A	3.25	3.75	0.128	0.148	3.25	3.75	0.128	0.148	3.25	3.75	0.128	0.148
A1	0.64	—	0.025	—	0.64	—	0.025	—	0.64	—	0.025	—
A2	2.08	—	0.082	—	2.08	—	0.082	—	2.08	—	0.082	—
B	0.38	0.51	0.015	0.020	0.38	0.51	0.015	0.020	0.38	0.51	0.015	0.020
b	0.66	0.81	0.026	0.032	0.66	0.81	0.026	0.032	0.66	0.81	0.026	0.032
C	0.18	0.33	0.007	0.013	0.18	0.33	0.007	0.013	0.18	0.33	0.007	0.013
D	25.91	26.16	1.020	1.030	27.18	27.43	1.070	1.080	28.45	28.70	1.120	1.130
E	11.05	11.30	0.435	0.445	11.05	11.30	0.435	0.445	11.05	11.30	0.435	0.445
E1	10.03	10.29	0.395	0.405	10.03	10.29	0.395	0.405	10.03	10.29	0.395	0.405
E2	9.40 BSC		0.370 BSC		9.40 BSC		0.370 BSC		9.40 BSC		0.370 BSC	
e	1.27 BSC		0.050 BSC		1.27 BSC		0.050 BSC		1.27 BSC		0.050 BSC	

Copyright © 2003 Integrated Silicon Solution, Inc. All rights reserved. ISSI reserves the right to make changes to this specification and its products at any time without notice. ISSI assumes no liability arising out of the application or use of any information, products or services described herein. Customers are advised to obtain the latest version of this device specification before relying on any published information and before placing orders for products.

# PACKAGING INFORMATION



## Mini Ball Grid Array Package Code: B (48-pin)

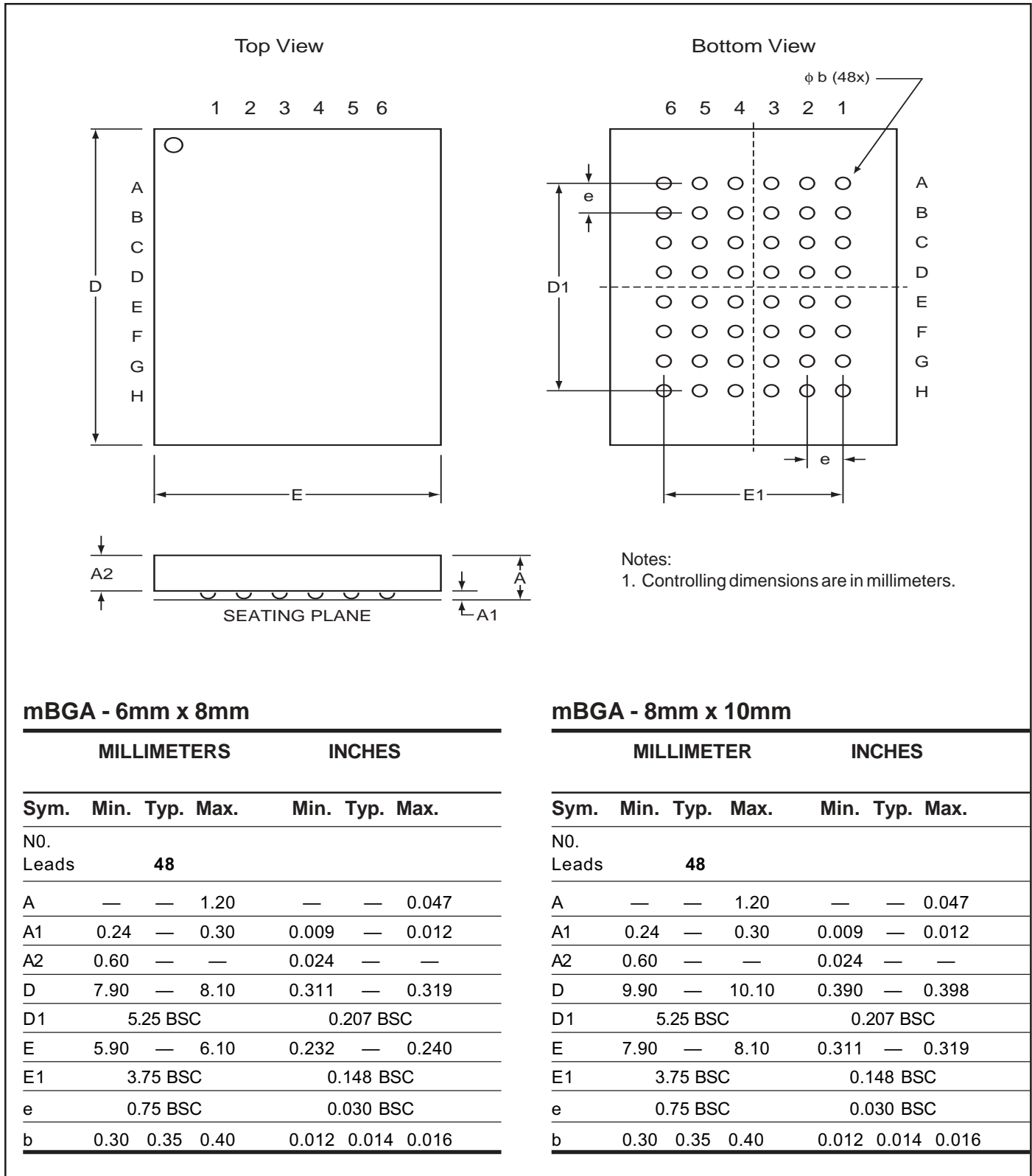

Copyright © 2003 Integrated Silicon Solution, Inc. All rights reserved. ISSI reserves the right to make changes to this specification and its products at any time without notice. ISSI assumes no liability arising out of the application or use of any information, products or services described herein. Customers are advised to obtain the latest version of this device specification before relying on any published information and before placing orders for products.

Integrated Silicon Solution, Inc. — [www.issi.com](http://www.issi.com) — 1-800-379-4774

Rev. D  
01/15/03

# PACKAGING INFORMATION



## Plastic TSOP Package Code: T (Type II)



### Notes:

1. Controlling dimension: millimeters, unless otherwise specified.
2. BSC = Basic lead spacing between centers.
3. Dimensions D and E1 do not include mold flash protrusions and should be measured from the bottom of the package.
4. Formed leads shall be planar with respect to one another within 0.004 inches at the seating plane.

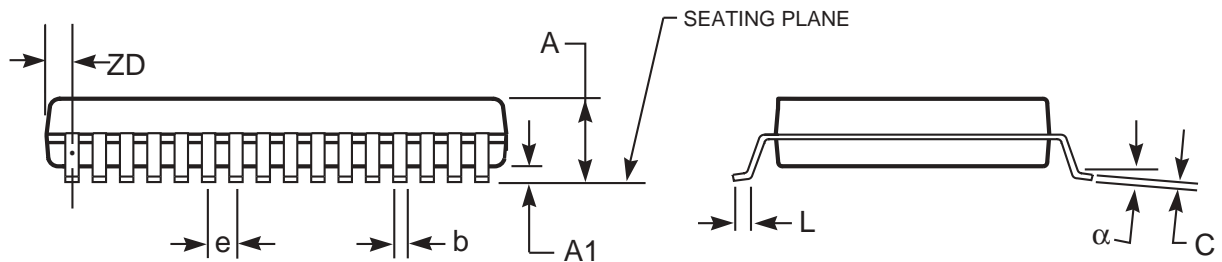

Plastic TSOP (T - Type II)

Symbol	Millimeters		Inches		Millimeters		Inches		Millimeters		Inches	
	Min	Max	Min	Max	Min	Max	Min	Max	Min	Max	Min	Max
Ref. Std.												
No. Leads (N)	32				44				50			
A	—	1.20	—	0.047	—	1.20	—	0.047	—	1.20	—	0.047
A1	0.05	0.15	0.002	0.006	0.05	0.15	0.002	0.006	0.05	0.15	0.002	0.006
b	0.30	0.52	0.012	0.020	0.30	0.45	0.012	0.018	0.30	0.45	0.012	0.018
C	0.12	0.21	0.005	0.008	0.12	0.21	0.005	0.008	0.12	0.21	0.005	0.008
D	20.82	21.08	0.820	0.830	18.31	18.52	0.721	0.729	20.82	21.08	0.820	0.830
E1	10.03	10.29	0.391	0.400	10.03	10.29	0.395	0.405	10.03	10.29	0.395	0.405
E	11.56	11.96	0.451	0.466	11.56	11.96	0.455	0.471	11.56	11.96	0.455	0.471
e	1.27 BSC		0.050 BSC		0.80 BSC		0.032 BSC		0.80 BSC		0.031 BSC	
L	0.40	0.60	0.016	0.024	0.41	0.60	0.016	0.024	0.40	0.60	0.016	0.024
ZD	0.95 REF		0.037 REF		0.81 REF		0.032 REF		0.88 REF		0.035 REF	
α	0°	5°	0°	5°	0°	5°	0°	5°	0°	5°	0°	5°

Copyright © 2003 Integrated Silicon Solution, Inc. All rights reserved. ISSI reserves the right to make changes to this specification and its products at any time without notice. ISSI assumes no liability arising out of the application or use of any information, products or services described herein. Customers are advised to obtain the latest version of this device specification before relying on any published information and before placing orders for products.

Integrated Silicon Solution, Inc. — [www.issi.com](http://www.issi.com) — 1-800-379-4774

Rev. F  
06/18/03