

ORDERING INFORMATION

PART NUMBER	CURRENT LIMIT	TEMPERATURE RANGE	PACKAGE	PINS	PACKAGING
ACT6390MH-T	1.7A	-40°C to 85°C	MSOP-8	8	TAPE & REEL
ACT6391MH-T	2.5A	-40°C to 85°C	MSOP-8	8	TAPE & REEL

PIN CONFIGURATION

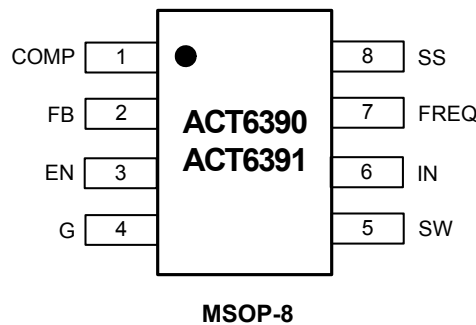

PIN DESCRIPTIONS

PIN	NAME	DESCRIPTION
1	COMP	Error Amplifier Compensation Node. Connect to a resistor R_C and capacitor C_C in series to ground.
2	FB	Feedback Input. Connect this pin a resistor divider from the output to set the output voltage. FB is regulated to 1.24V.
3	EN	Enable Control. Connect to a logic high level to enable the IC. Connect to a logic low level to disable the IC. When unused, connect EN pin to IN (do not leave pin floating).
4	G	Ground.
5	SW	Switch Output. Connect this pin to the inductor and the schottky diode. To minimize EMI, minimize the PCB trace path between this pin and the input bypass capacitor.
6	IN	Supply Input. Bypass to G with a $1\mu\text{F}$ or larger capacitor.
7	FREQ	Frequency Setting Pin. A logic low sets the switching frequency at 700kHz. A logic high sets the switching frequency at 1.3MHz. This pin has an internal $5.5\mu\text{A}$ pull-down current.
8	SS	Soft Start Control Input. Connect a capacitor from this pin to G to set soft-start timing duration ($t_{SS} = 2.2 \times 10^5 \times C_{SS}$). SS is discharged to ground in shutdown. SS may be left unconnected if soft start is not desired.

ABSOLUTE MAXIMUM RATINGS^①

PARAMETER	VALUE	UNIT
SW to G	-0.3 to 14	V
IN, EN, FB, FREQ, COMP to G	-0.3 to 6	V
SS to G	-0.3 to $V_{IN} + 0.3$	V
Continuous SW Current	Internally Limited	A
Junction to Ambient Thermal Resistance (θ_{JA})	200	°C/W
Maximum Power Dissipation	0.5	W
Operating Junction Temperature	-40 to 150	°C
Storage Temperature	-55 to 150	°C
Lead Temperature (Soldering, 10 sec)	300	°C

①: Do not exceed these limits to prevent damage to the device. Exposure to absolute maximum rating conditions for long periods may affect device reliability.

ELECTRICAL CHARACTERISTICS

 ($V_{IN} = V_{EN} = 3V$, $V_{FREQ} = 0V$, $T_A = 25^\circ C$, unless otherwise specified.)

PARAMETER	TEST CONDITIONS	MIN	TYP	MAX	UNIT	
Switch Voltage Rating				12	V	
Input Voltage		2.7		5.5	V	
Under Voltage Lockout Threshold	V_{IN} Rising	2.2	2.35	2.5	V	
Under Voltage Lockout Hysteresis			65		mV	
Quiescent Supply Current	$V_{FB} = 1.3V$, Not Switching		0.2	0.35	mA	
	$V_{FB} = 1.0V$, Switching	ACT6390	1	4		
		ACT6391	1.4	4		
Supply Current in Shutdown	EN = G		0.1	10	μA	
Switching Frequency	FREQ = G	490	700	910	kHz	
	FREQ = IN	900	1300	1700		
Maximum Duty Cycle	FREQ = G	80	86	92	%	
	FREQ = IN		86			
FB Feedback Voltage		1.22	1.24	1.26	V	
FB Input Current	$V_{FB} = 1.27V$		0	80	nA	
FB Voltage Line Regulation	V_{FB} from 2.6V to 5.5V		0.05	0.15	%/V	
Error Amplifier Trans-conductance	$\Delta I = 5\mu A$	70	150	240	μs	
Error Amplifier Output Current	$V_{FB} = 1.15V$ and $1.35V$, $V_{COMP} = 1.1V$		11		μA	
Switch Current Limit	$V_{FB} = 1V$, Duty Cycle = 65%	ACT6390	1.2	1.7	2.3	A
		ACT6391	1.8	2.5	3.4	
Switch On Resistance	ACT6390		0.2	0.4	Ω	
	ACT6391		0.15	0.3		
Switch Leakage Current	$V_{SW} = 12V$, EN = G			15	μA	
Current Sense Trans-resistance	ACT6390		0.45		V/A	
	ACT6391		0.3			
Soft Start Pin Bias Current	$V_{SS} = 1.2V$	2	4.5	7	μA	
Soft Start Reset Resistance	$V_{SS} = 1.2V$, $V_{EN} = 0V$		110	220	Ω	
Logic High Threshold	EN, FREQ	1.4			V	
Logic Low Threshold	EN, FREQ			0.4	V	
EN Input Current	$V_{EN} = 0V$ or $5V$		0	1	μA	
FREQ Pull-down Current	$V_{FREQ} = 3V$	2.5	5.5	8.5	μA	
Thermal Shutdown Temperature			160		$^\circ C$	
Thermal Shutdown Hysteresis			20		$^\circ C$	

FUNCTIONAL BLOCK DIAGRAM

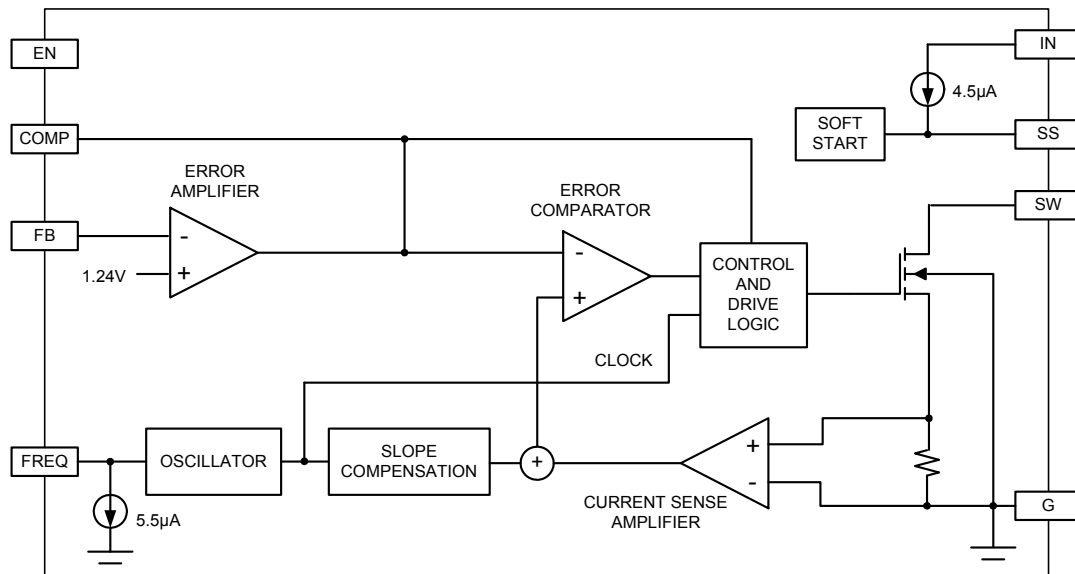

FUNCTIONAL DESCRIPTION

The ACT6390 and ACT6391 are highly efficient step-up DC/DC converters that employ a current-mode, fixed frequency pulse-width modulation (PWM) architecture with excellent line and load regulation.

The ACT6390 and ACT6391 operate at constant switching frequency under medium to high load current conditions. At light loads, these devices operate in a pulse-skipping mode in order to improve light-load efficiency.

Soft-Start

The ACT6390 and ACT6391 both offer a programmable soft-start function which minimizes inrush current during startup. The soft-start period is programmed by connecting a capacitor (C_{SS}) between SS and G. Operation of the soft-start function is as follows: when the IC is disabled, SS is actively discharged to G. Upon enabling the IC, C_{SS} is charged with a 4.5µA current so that the voltage at SS increases in a controlled manner. The peak inductor current is limited by the voltage at SS, so that the input current is limited until the soft-start period expires, and the regulator can achieve its full output current rating.

The soft-start period can be calculated as a simple function of the soft-start capacitor using the equation:

$$t_{SS} = 2.2 \times 10^5 \times C_{SS} \quad (1)$$

Frequency Selection

The ACT6390 and ACT6391 include a pin-selectable operating frequency drive FREQ to a logic high for 1.3MHz operation, drive FREQ to a logic low for 700kHz operation.

Selectable operating frequency, in combination with the external compensation network, allows a wide range of flexibility in optimizing total solution size and cost.

FREQ is internally pulled down by 5.5µA, this pin may be left unconnected to achieve a 700kHz operating frequency.

Setting the Output Voltage

The ACT6390 and ACT6391 both feature external adjustable output voltages of up to 12V. To program the output voltage, simply connect a resistive voltage divider between the output, FB, and G, with resistors set according to the following equation:

$$R1 = R2 \times \left[\left(\frac{V_{OUT}}{V_{FB}} \right) - 1 \right] \quad (2)$$

Where V_{FB} is 1.24V.

Inductor Selection

As a step-up converter, the switch duty cycle (D) is determined by the input voltage (V_{IN}) and output voltage (V_{OUT}), as given by the following formula:

$$D = \frac{V_{OUT} - V_{IN}}{V_{OUT}} \quad (3)$$

Define

$$K = \frac{\Delta I_L}{I_{L(DC)}} \quad (4)$$

Where: ΔI_L is the inductor ripple current in steady state, typically chosen to be about 0.3, and

$$\Delta I_L = \frac{V_{IN}}{L} DT = \frac{V_{IN} \times D}{L \times f_{SW}} \quad (5)$$

$I_{L(DC)}$ is the inductor DC current, given by:

$$I_{L(DC)} = \frac{V_{OUT} \times I_{OUT}}{V_{IN} \times \eta} \quad (6)$$

Where η is typical efficiency.

Solving equations (3),(4),(5) and (6) for the inductor value,

$$L = \left(\frac{V_{IN}}{V_{OUT}} \right)^2 \frac{(V_{OUT} - V_{IN}) \times \eta}{I_{OUT} \times f_{SW} \times K} \quad (7)$$

This equation can be used to determine the correct trade-off between efficiency, current ripple, size and cost.

When selecting an inductor make sure that the inductors maximum DC current and saturation current exceed the maximum operation point, calculated by:

$$I_{L(DC,MAX)} = \frac{I_{OUT(MAX)} \times V_{OUT}}{V_{IN(MIN)} \times \eta} \quad (8)$$

and

$$I_{L(PEAK,MAX)} = I_{L(DC,MAX)} + \frac{1}{2} \Delta I_{L(MAX)} \\ = \frac{I_{OUT(MAX)} \times V_{OUT}}{V_{IN(MIN)} \times \eta} + \frac{1}{2} \times \frac{V_{IN(MIN)} [V_{OUT} - V_{IN(MIN)}]}{V_{OUT} \times L \times f_{SW}} \quad (9)$$

If the output voltage is greater than two times of input voltage, that means the duty cycle is greater than 50%, the slope compensation is required for stability. When operating in this condition ensure that the inductor value is greater than L_{MIN} :

$$L > L_{MIN} = \frac{(V_{OUT} - V_{IN}) \times R_{CS}}{1.75 \times f_{SW}} \quad (10)$$

Where R_{CS} is the current sense trans-resistance, R_{CS} is 0.45Ω for ACT6390, and $R_{CS} = 0.3\Omega$ for ACT6391.

For example: $V_{IN} = 3.3V$, $V_{OUT} = 12V$, $f_{SW} = 700kHz$, $I_{OUT} = 250mA$, $\eta = 85\%$, $FREQ = G$, $K = 0.4$

$$L = \left(\frac{V_{IN}}{V_{OUT}} \right)^2 \left(\frac{V_{OUT} - V_{IN}}{I_{OUT} \times f_{SW}} \right) \times \frac{\eta}{K} \quad (11) \\ = \left(\frac{3.3V}{12V} \right)^2 \left(\frac{12V - 3.3V}{250mA \times 700kHz} \times \frac{0.85}{0.4} \right) \approx 7.99\mu H$$

Select $L = 10\mu H$

Assuming the minimum input voltage is 3V and low cost external components are used, yielding a low efficiency of just 80%.

$$I_{L(DC,MAX)} = \frac{250mA \times 12V}{3V \times 0.8} = 1.25A \quad (12)$$

$$\Delta I_{L(MAX)} = \frac{3V \times (12V - 3V)}{12V \times 10\mu H \times 700kHz} = 0.32A \quad (13)$$

$$I_{PEAK(MAX)} = 1.25A + \frac{1}{2} 0.32A = 1.41A \quad (14)$$

For stability,

$$L_{MIN} = \frac{(12V - 3.3V) \times 0.45\Omega}{1.75 \times 700kHz} = 3.2\mu H \quad (15)$$

Which meets the slope compensation requirement.

Loop Compensation

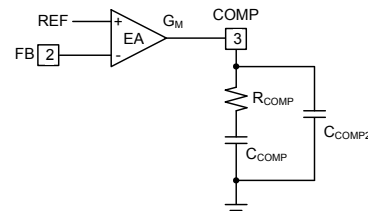

The ACT6390 and ACT6391 feature a simple loop compensation scheme. Simple follow the procedure detailed below to determine suitable compensation components. For best results be sure to prototype to confirm the values, and adjust the compensation network (by inspecting the transient response, for example) as needed to optimize results for your particular application.

When the converter operates with continuous inductor current, a right-half-plane zero exists in the loop's gain-frequency response. To ensure stability,

the cross-over frequency (unity gain-frequency) should be less than one-fifth of the right-half-plane zero $f_{Z(RHP)}$, and lower than one-fifteenth of switching frequency f_{sw} .

$$f_{Z(RHP)} = \frac{V_{IN}^2 \times R_{LOAD}}{2V_{OUT}^2 \times \pi \times L} \quad (16)$$

Choose $f_C = \frac{1}{5} f_{Z(RHP)}$, then calculate C_{COMP} :

$$\begin{aligned} C_{COMP} &= \frac{V_{FB}}{V_{OUT}} \times \frac{R_{LOAD}}{R_{CS}} \times \frac{G_M}{2\pi f_C} (1-D) \\ &= \frac{V_{IN} \times V_{FB}}{V_{OUT}^2} \times \frac{R_{LOAD} \times G_M}{R_{CS} \times 2\pi f_C} \end{aligned} \quad (17)$$

Select R_{COMP} to meet the transient-droop requirements.

$$\alpha \times V_{FB} \times G_M \times R_{COMP} = R_{CS} \times \frac{V_{OUT} \times I_{OUT}}{V_{IN} \times \eta} \times \left(1 + \frac{K}{2}\right) \quad (18)$$

$$R_{COMP} = \frac{R_{CS} \times V_{OUT} \times I_{OUT} \left(1 + \frac{K}{2}\right)}{\alpha \times V_{FB} \times G_M \times V_{IN} \times \eta} \quad (19)$$

Where:

α is the transient droop percentage which can be accepted, calculated by:

$$\alpha = \frac{\Delta V_{OUT}}{V_{OUT}} \quad (20)$$

K: is defined in equation (4)

η : is the typical efficiency.

V_{FB} : is the feedback voltage, 1.24V

G_M : is the trans-conductance of the error amplifier.

The output capacitor is chosen to set the output pole for canceling the R_{COMP} , C_{COMP} zero.

$$C_{OUT} = \frac{R_{COMP} \times C_{COMP}}{R_{LOAD}} \quad (21)$$

C_{COMP2} is optional and can be used when the output capacitor has significant ESR. The ESR will form a zero as follows:

$$f_{Z(ESR)} = \frac{1}{2\pi \times R_{ESR} \times C_{OUT}} \quad (22)$$

If this zero occurs at a higher frequency than the cross-over frequency, it can be ignored. Otherwise, it should be canceled with the pole set by capacitor

C_{COMP2} ,

$$C_{COMP2} = \frac{C_{OUT} \times R_{ESR}}{R_{COMP}} \quad (23)$$

If the value of C_{COMP2} calculated by (23) is smaller than 10pF, C_{COMP2} can be omitted.

For example:

$$f_{Z(RHP)} = \frac{(3.3V)^2 \times \left(\frac{12V}{250mA}\right)}{2 \times (12V)^2 \times \pi \times 10\mu H} \approx 57.8kHz \quad (24)$$

Choose $f_C = \frac{1}{5} f_{Z(RHP)} = 11.56kHz$

$$C_{COMP} = \frac{3.3V \times 1.24V}{(12V)^2} \times \frac{48\Omega}{0.45\Omega} \times \frac{150\mu S}{2\pi \times 11.56kHz} = 6.26nF \quad (25)$$

Choose $C_{COMP} = 6.8nF$

Assume that 200mV of transient droop can be accepted:

$$\alpha = \frac{200mV}{12V} = \frac{1}{60} \quad (26)$$

$$R_{COMP} = \frac{0.45\Omega \times 12V \times 250mA \left(1 + \frac{0.4}{2}\right)}{\frac{1}{60} \times 1.24V \times 150\mu S \times 3.3V \times 0.85} = 186.3k\Omega \quad (27)$$

Choose $R_{COMP} = 180k\Omega$

$$C_{OUT} = \frac{R_{COMP} \times C_{COMP}}{R_{LOAD}} = \frac{180k\Omega \times 6.8nF}{\left(\frac{12V}{0.25A}\right)} = 25.5\mu F \quad (28)$$

C_{OUT} can be chosen to be either 22 μ F or 33 μ F, choose 33 μ F to reduce droop.

$$R_{COMP} = \frac{R_{LOAD} \times C_{OUT}}{C_{COMP}} = \frac{48\Omega \times 33\mu F}{6.8nF} = 233k\Omega \quad (29)$$

If a ceramic capacitor is used with an assumed ESR of 20m Ω ,

$$f_{Z(ESR)} = \frac{1}{2\pi \times 33\mu F \times 20m\Omega} = 241kHz \quad (30)$$

$f_{Z(ESR)} > f_C$

Since the zero frequency is greater than the pole frequency, C_{COMP2} can be omitted.

If a tantalum capacitor is used, whose ESR is about 0.5 Ω ,

$$f_{Z(ESR)} = \frac{1}{2\pi \times 33\mu F \times 0.5\Omega} = 9.64\text{kHz} \quad (31)$$

$$f_{Z(ESR)} < f_c$$

$$C_{COMP2} = \frac{R_{ESR} \times C_{OUT}}{R_{COMP}} = \frac{0.5\Omega \times 33\mu F}{233\text{k}\Omega} = 70.8\text{pF} \quad (32)$$

Choose $C_{COMP2} = 82\text{pF}$

Rectifier Selection

For optimal performance, the rectifier should be a Schottky rectifier that is rated to handle both the output voltage as well as the peak switch current.

Over Voltage Protection

The ACT6390 and ACT6391 both feature internal automatic over-voltage protection (OVP). Once the outputs achieve regulation, if the voltage at FB falls below 0.125V the controller will automatically disable and latch off, preventing the controller from running open-loop and potentially damaging the IC and load.

To re-enable the converters, simply cycle the EN pin or remove and reapply power to the input.

Shutdown

Drive EN low to disable the IC and reduce the supply current to just 0.1μA. As with all non-synchronous step-up DC/DC converters, the external Schottky diode provides a DC path from the input to the output in shutdown. As a result, the output drops to one diode voltage drop below the input in shutdown.

Thermal Shutdown

The ACT6390 and ACT6391 both feature integrated thermal overload protection. Both devices are automatically disabled when their junction temperatures exceed 160°C, and automatically re-enable when the die temperature decreases by 20°C.

TYPICAL PERFORMANCE CHARACTERISTICS

($V_{IN} = V_{EN} = 3.3V$, FREQ = G, $T_A = 25^\circ C$, unless otherwise specified.)

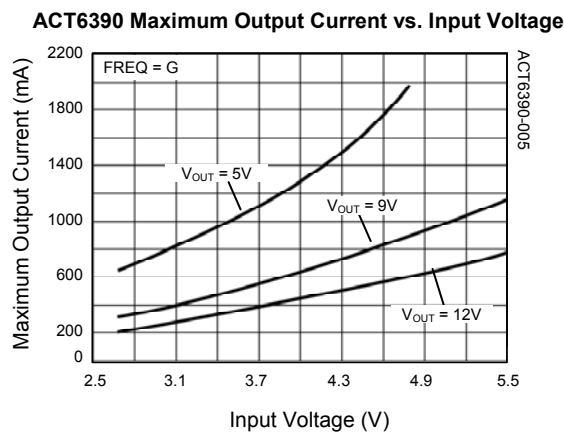
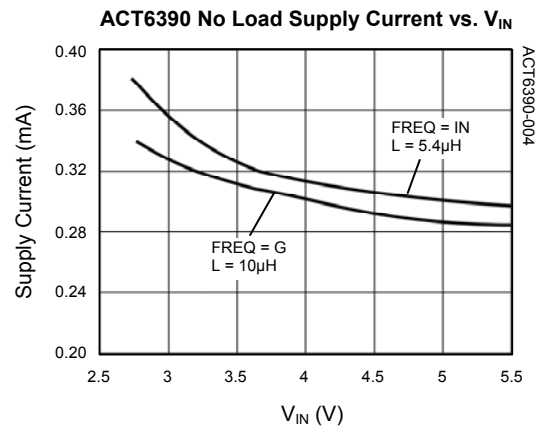
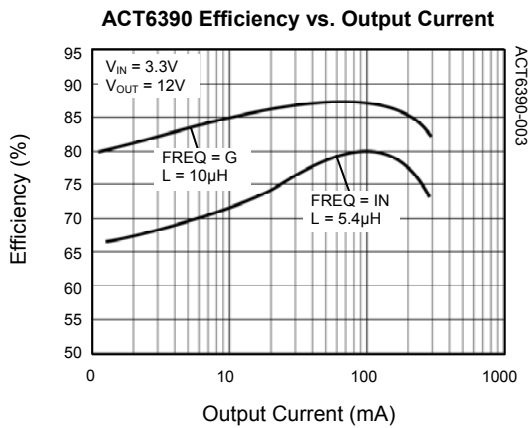
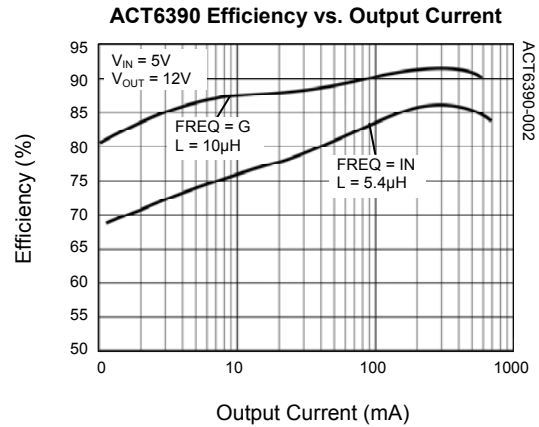
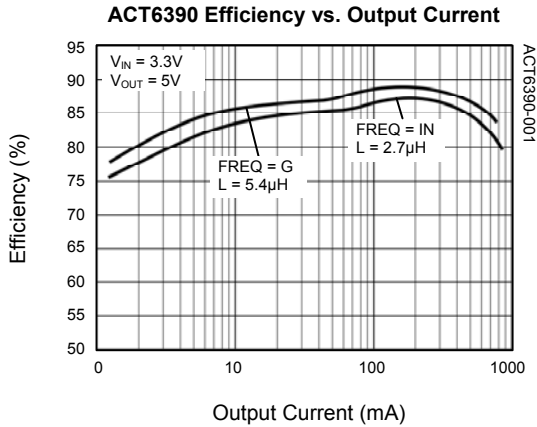

TYPICAL PERFORMANCE CHARACTERISTICS

($V_{IN} = V_{EN} = 3.3V$, FREQ = G, $T_A = 25^\circ C$, unless otherwise specified.)

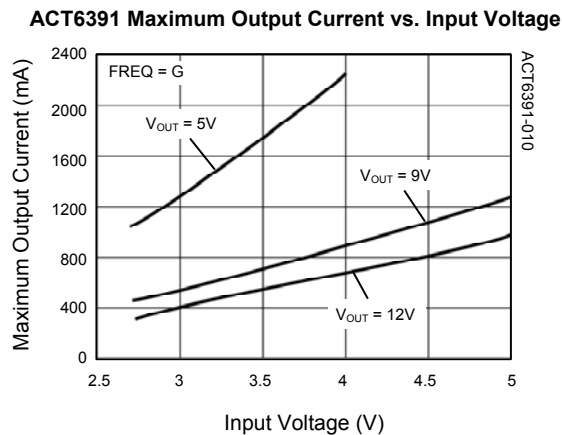
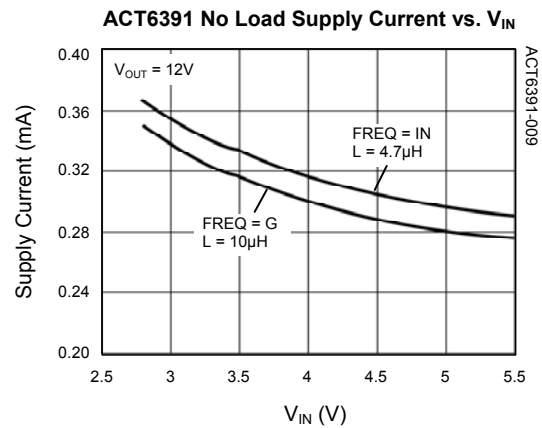
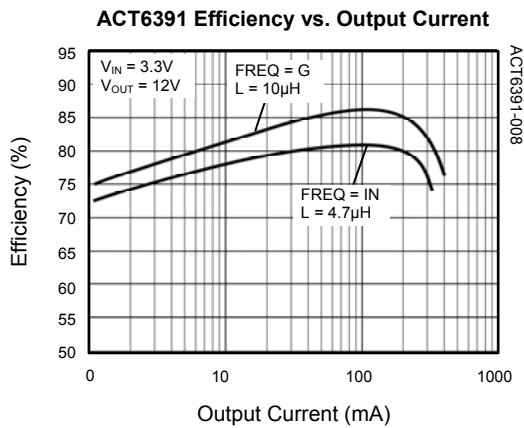
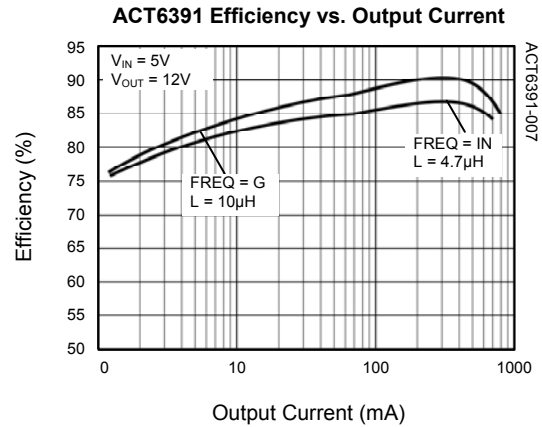
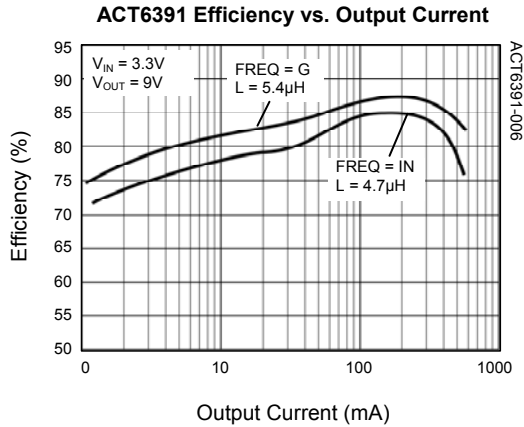

PACKAGE OUTLINE

MSOP-8 PACKAGE OUTLINE AND DIMENSIONS

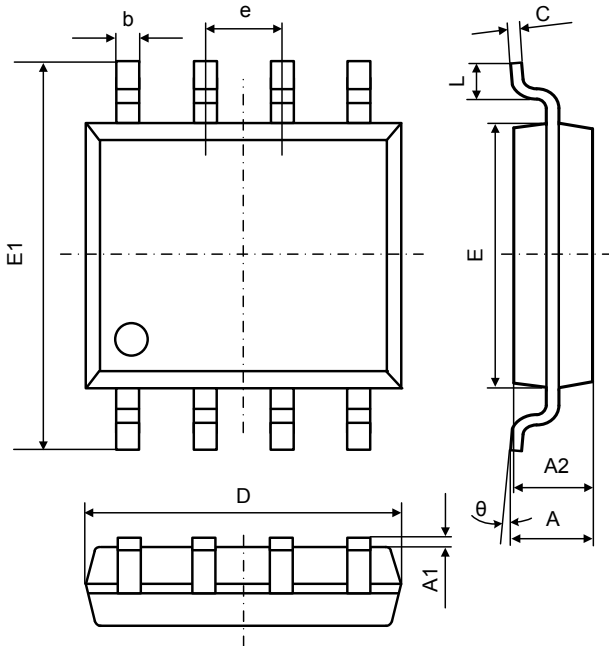

SYMBOL	DIMENSION IN MILLIMETERS		DIMENSION IN INCHES	
	MIN	MAX	MIN	MAX
A	0.820	1.100	0.032	0.043
A1	0.020	0.150	0.001	0.006
A2	0.750	0.950	0.030	0.037
b	0.250	0.380	0.010	0.015
C	0.090	0.230	0.004	0.009
D	2.900	3.100	0.114	0.122
E	2.900	3.100	0.114	0.122
E1	4.750	5.050	0.187	0.199
e	0.650 TYP		0.026 TYP	
L	0.400	0.800	0.016	0.031
theta	0°	6°	0°	6°

Active-Semi, Inc. reserves the right to modify the circuitry or specifications without notice. Users should evaluate each product to make sure that it is suitable for their applications. Active-Semi products are not intended or authorized for use as critical components in life-support devices or systems. Active-Semi, Inc. does not assume any liability arising out of the use of any product or circuit described in this datasheet, nor does it convey any patent license.

Active-Semi and its logo are trademarks of Active-Semi, Inc. For more information on this and other products, contact sales@active-semi.com or visit <http://www.active-semi.com>.

 is a registered trademark of Active-Semi.