

## Absolute Maximum Ratings

Absolute maximum ratings indicate sustained limits beyond which damage to the device may occur. All voltage parameters are referenced to Vcc lead. (Tambient=25°C unless otherwise specified).

Symbol	Parameter	Min.	Max.	Units
Vcc-Vin	Maximum Vcc voltage	-16	37	V
Vcc-Vin cont.	Maximum continuous Vcc voltage	-16	32	
Vcc-Vfb	Maximum lfb voltage	-16	33	
Vcc-Vout	Maximum output voltage	-0.3	37	
Ids cont.	Maximum body diode continuous current Rth=60°C/W (1)	—	2.8	A
Ids pulsed	Maximum body diode pulsed current (1)	—	100	
Pd	Maximum power dissipation Rth=60°C/W	—	2	W
ESD1	Electrostatic discharge voltage (Human body) C=100pF, R=1500Ω	—	4	kV
ESD2	Electrostatic discharge voltage (Machine Model) C=200pF,R=0Ω	—	0.5	
Tj max.	Max. storage & operating temperature junction temperature	-40	150	°C
Min Rfb	Minimum on the resistor on lfb pin	0.3	—	kΩ
lfb max.	Max. lfb current	-50	50	mA

(1) Limited by junction temperature. Pulsed is also limited by wiring

## Thermal Characteristics

Symbol	Parameter	Typ.	Max.	Units
Rth1	Thermal resistance junction to ambient D <sup>2</sup> -Pak Std footprint	60	—	°C/W
Rth2	Thermal resistance junction to case D <sup>2</sup> -Pak	0.7	—	
Rth2	Thermal resistance junction to case TO220	0.7	—	

## Recommended Operating Conditions

These values are given for a quick design. For operation outside these conditions, please consult the application notes.

Symbol	Parameter	Min.	Max.	Units
Iout	Continuous output current	—	23	A
	Tambient=85°C, Rth=5°C/W, Tj=125°C			
	Tambient=85°C, Rth=60°C/W, Tj=125°C			
Rifb	Recommended lfb resistor (2)(3)	0.3	3.5	kΩ
Pulse min.	Minimum turn-on pulse width	1	—	ms
Fmax.	Maximum operating frequency	—	200	Hz

2) If Rifb is too low, the device can be damaged.

3) If Rifb is too high, the device may not switch on.

## Protection Characteristics

T<sub>j</sub>=25°C, R<sub>ifb</sub>=500 to 3.5kΩ

Symbol	Parameter	Min.	Typ.	Max.	Units	Test Conditions
V <sub>ifb-Vin@I<sub>sd</sub></sub>	Over-current shutdown threshold	4	4.7	5.6	V	
T <sub>sd</sub>	Over temperature threshold	—	165	—	°C	See fig. 5
OV	Over voltage protection (not latched)	33	35	39	V	
I <sub>sd</sub> f	Fixed over current shutdown	90	120	140	A	V <sub>ifb</sub> <V <sub>ifb-Vin@I<sub>sd</sub></sub> R <sub>ifb</sub> =1kΩ
I <sub>sd_1k</sub>	Programmable over current shutdown 1k	30	40	50		
T <sub>reset</sub>	Time to reset protection	—	50	500	μs	See fig. 5
Min. pulse	Min. pulse width (no WAIT state)	200	400	1200		
WAIT	WAIT function timer	0.4	1	2	ms	See fig. 4 and 5
R <sub>ds(on) rev.</sub>	Reverse battery On state resistance	4	6.7	10	mΩ	V <sub>cc-Vin</sub> =-14V, I <sub>out</sub> =30A

## Static Electrical Characteristics

T<sub>j</sub>=25°C, V<sub>cc</sub>=14V (unless otherwise specified)

Symbol	Parameter	Min.	Typ.	Max.	Units	Test Conditions
V <sub>cc op.</sub>	Operating Voltage range	6	—	32	V	
I <sub>cc off</sub>	Supply leakage current	—	1.5	5	μA	V <sub>in</sub> =V <sub>cc</sub> , V <sub>cc-Vout</sub> =14V, V <sub>cc-Vifb</sub> =14V
I <sub>in, on</sub>	On state I <sub>N</sub> positive current	1.5	3	6	mA	V <sub>cc-Vin</sub> =14V
V <sub>ih</sub>	High level Input threshold voltage (4)	—	5.4	6.2	V	
V <sub>il</sub>	Low level Input threshold voltage (4)	4	4.9	5.8		
V <sub>hyst</sub>	Input hysteresis V <sub>ih</sub> -V <sub>il</sub>	0.2	0.4	1		
I <sub>out</sub>	Drain to source leakage current	—	1.2	5	μA	V <sub>in</sub> =V <sub>cc</sub> , V <sub>cc-Vifb</sub> =0V, V <sub>cc-Vout</sub> =14V
R <sub>ds(on)</sub>	On state resistance (5) T <sub>j</sub> =25°C	4	5.5	7	mΩ	I <sub>out</sub> =30A, V <sub>cc-Vin</sub> =14V
	On state resistance (5) T <sub>j</sub> =25°C	4	6	10		I <sub>out</sub> =17A, V <sub>cc-Vin</sub> =6V
	On state resistance (5)(6) T <sub>j</sub> =150°C	7	10.5	13.5		I <sub>out</sub> =30A, V <sub>cc-Vin</sub> =14V
V <sub>clamp1</sub>	V <sub>cc</sub> to V <sub>out</sub> clamp voltage 1	36	39	—	V	I <sub>out</sub> =50mA
V <sub>clamp2</sub>	V <sub>cc</sub> to V <sub>out</sub> clamp voltage 2	—	40	43		I <sub>out</sub> =30A

(4) Input thresholds are measured directly between the input pin and the tab. Any parasitic resistance in common between the load current path and the input signal path can significantly affect the thresholds.

(5) R<sub>ds(on)</sub> is measured between the tab and the Out pin, 5mm away from the package.

(6) Guaranteed by design

## Switching Electrical Characteristics

V<sub>cc</sub>=14V, Resistive load=0.5Ω, T<sub>j</sub>=25°C

Symbol	Parameter	Min.	Typ.	Max.	Units	Test Conditions
T <sub>don</sub>	Turn on delay time to 10% V <sub>cc</sub>	8	32	80	μs	See figure 2
T <sub>r1</sub>	Rise time to V <sub>cc-Vout</sub> =5V	3	16	40		
T <sub>r2</sub>	Rise time to V <sub>cc-Vout</sub> =0.1V <sub>cc</sub>	10	40	100		
E <sub>on</sub>	Turn on energy	—	4.5	—	mJ	
T <sub>doff</sub>	Turn off delay time	20	80	200	μs	
T <sub>f</sub>	Fall time to V <sub>out</sub> =10% of V <sub>cc</sub>	8	32	80		
E <sub>off</sub>	Turn off energy	—	2	—	mJ	

### Current Sense Characteristics

Symbol	Parameter	Min.	Typ.	Max.	Units	Test Conditions
Ratio	I Load/I <sub>fb</sub> current ratio	7,500	8,800	9,950	—	T <sub>j</sub> =25°C, R <sub>fb</sub> =500Ω, I <sub>out</sub> =60A
Ratio_TC	I Load/I <sub>fb</sub> variation aver temperature(6)	-5	—	+5	%	T <sub>j</sub> =-40°C to 150°C
Offset	Load current diagnostic offset	-0.22	0	+0.2	A	I <sub>out</sub> =2A
Trst	I <sub>fb</sub> response time (low signal)	—	1	—	μs	90% of the I <sub>out</sub> step

### Functional Block Diagram

All values are typical

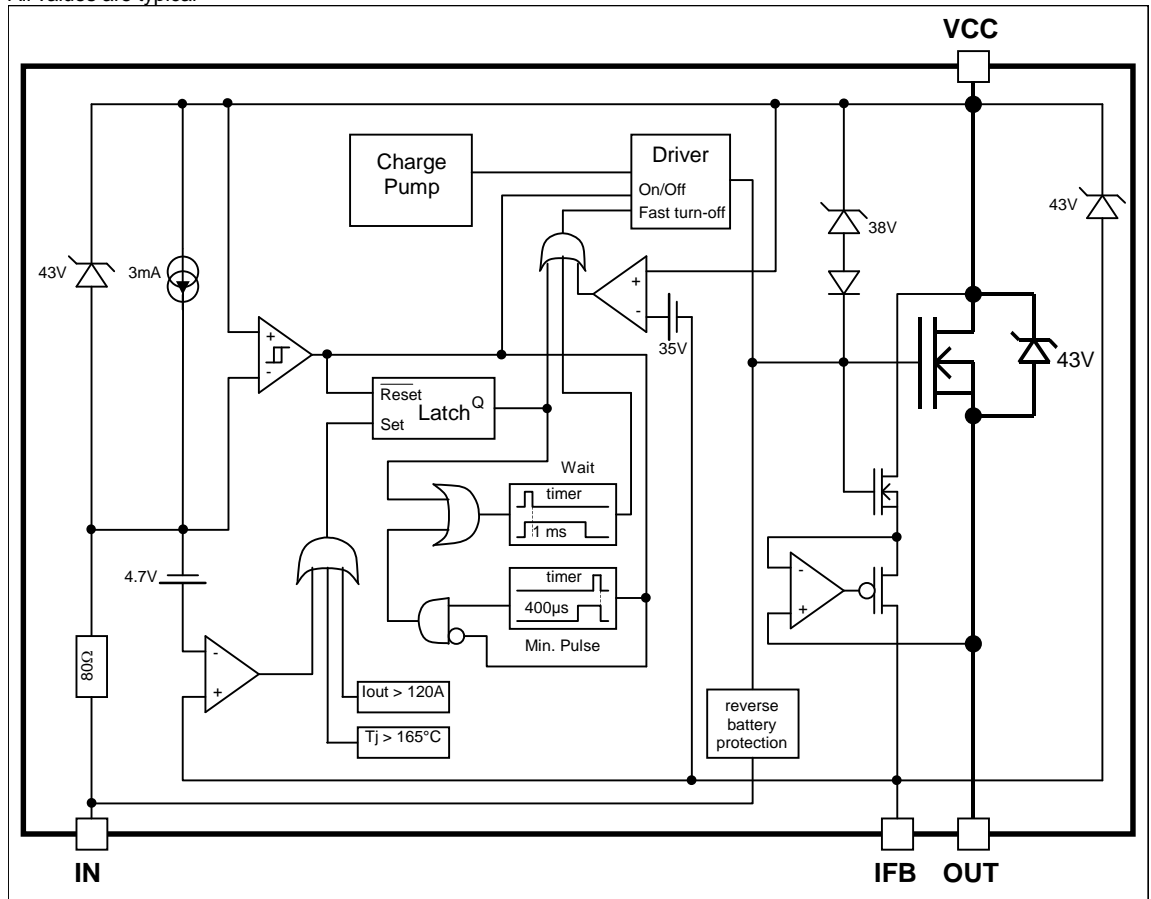

## Lead Assignments

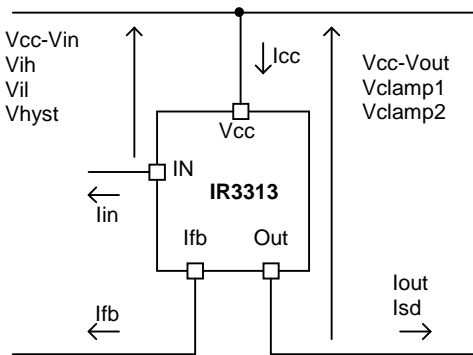
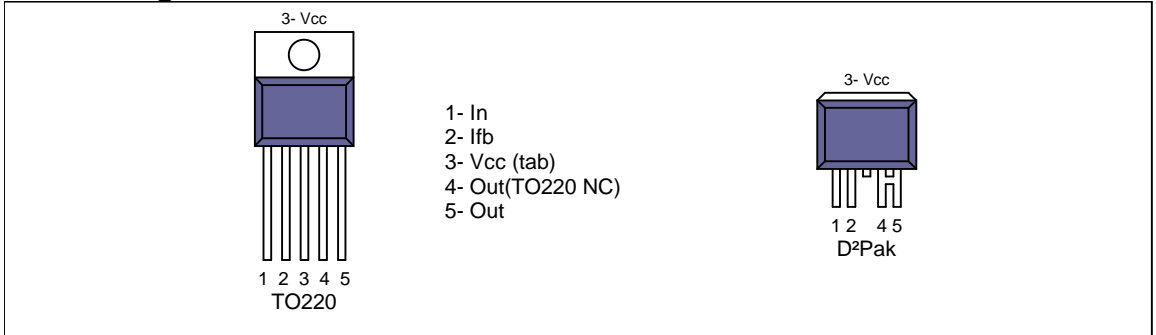

Figure 1 – Voltages and current definitions

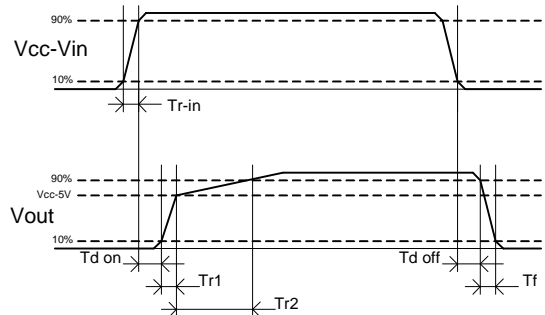

Figure 2 – Switching time definitions

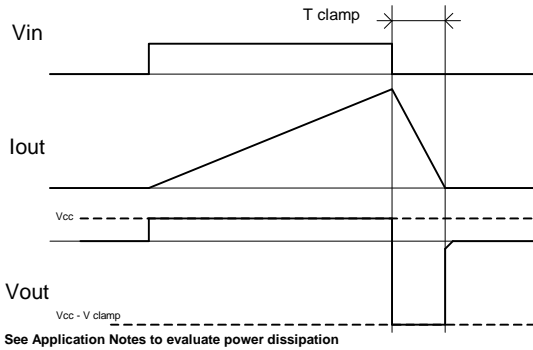

Figure 3 – Active clamp waveforms

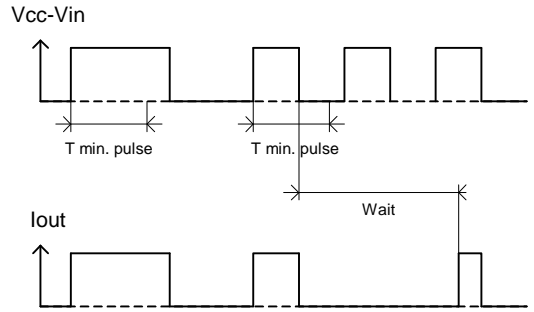

Figure 4 – Min. pulse and Wait function

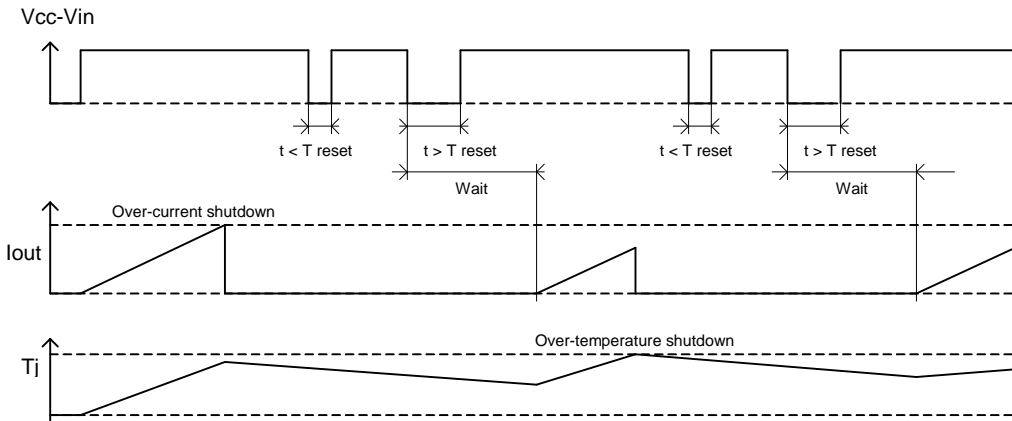
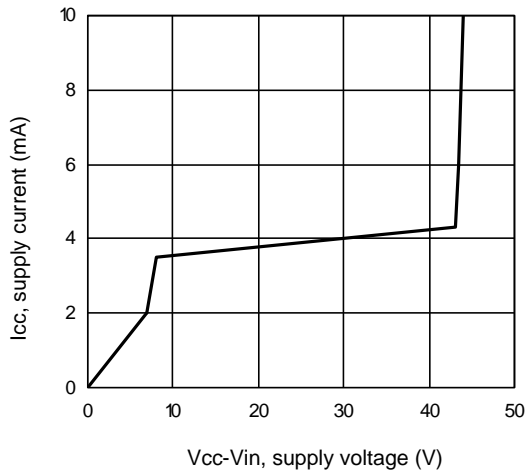
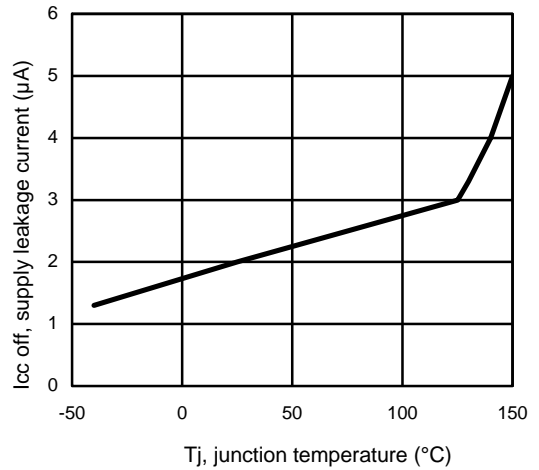

Figure 5 – Protection Timing Diagrams

All curves are typical characteristics. Operation in hatched areas is not recommended.  $T_j=25^\circ\text{C}$ ,  $R_{\text{th}}=500\text{ohm}$ ,  $V_{\text{cc}}=14\text{V}$  (unless otherwise specified).



**Figure 6 – Icc (mA) Vs Vcc-Vin (V)**



**Figure 7 – Icc off (µA) Vs Tj (°C)**

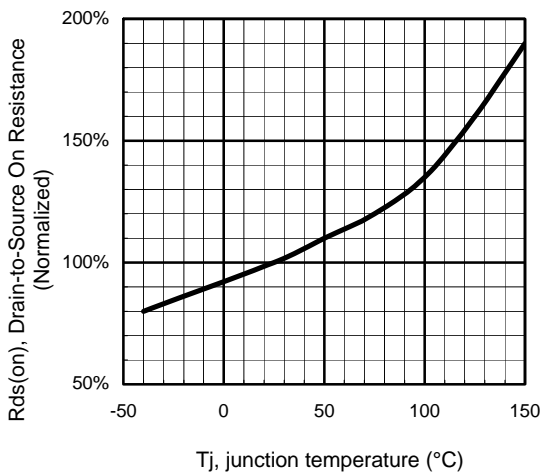

**Figure 8 - Normalized Rds(on) (%) Vs Tj (°C)**

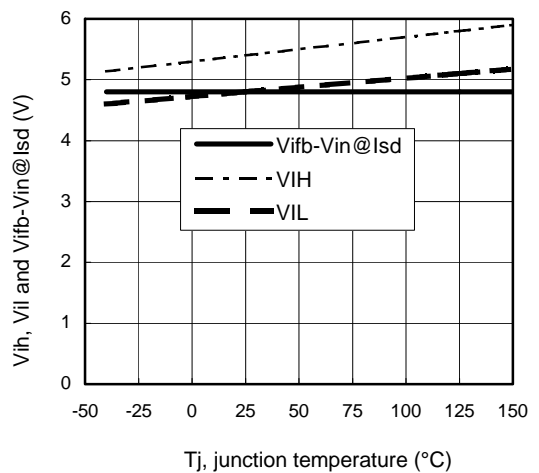

**Figure 9 – Vih, Vil and Vifb-Vin@Isd (V) Vs Tj (°C)**

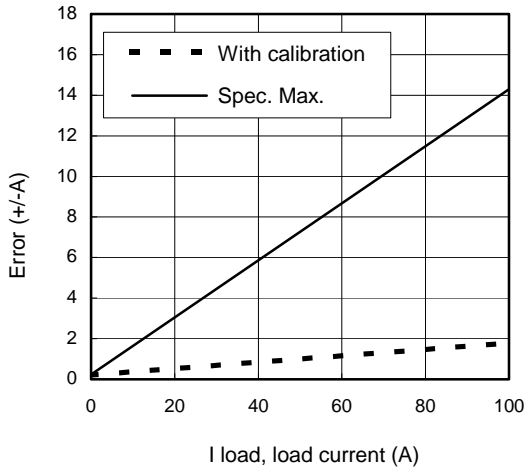

Figure 10 – Error (+/- A) Vs I load (A)

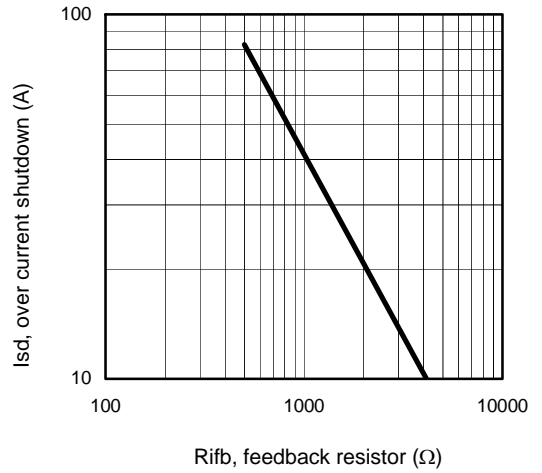

Figure 11 – Ids (A) Vs Rifb (Ω)

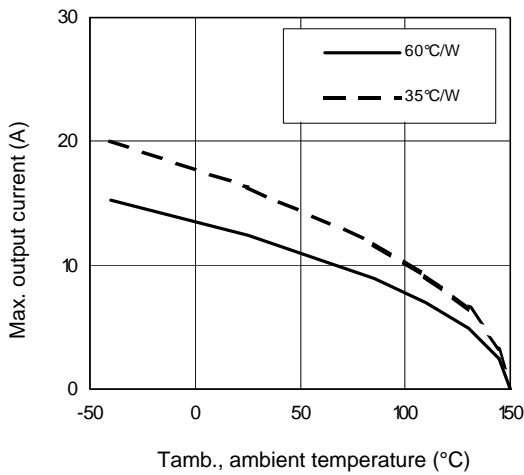

Figure 12 – Max. iout (A) Vs Tamb. (°C)

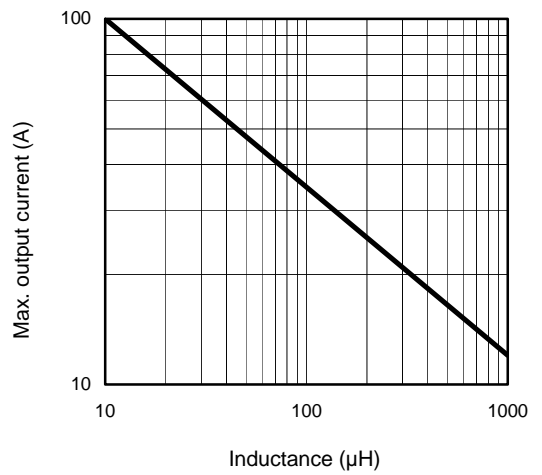
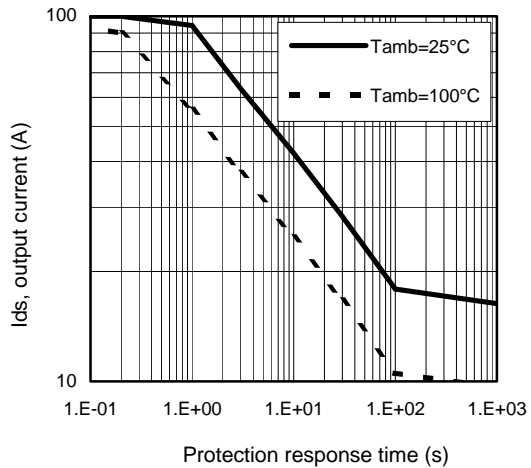
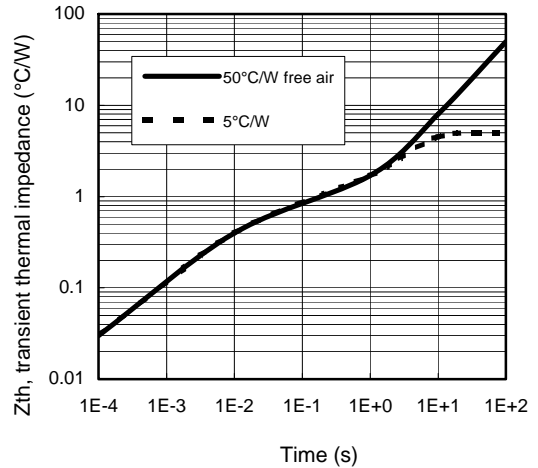

Figure 13 – Max. iout (A) Vs inductance (μH)



**Figure 14 –  $I_{ds}$  (A) Vs over temperature protection response time (s)/  $R_{th}=60^{\circ}\text{C/W}$**



**Figure 15 – Transient thermal impedance (°C/W) Vs time (s)**



Case Outline 5 Leads - D2PAK – Automotive Q100 PbF MSL1 qualified

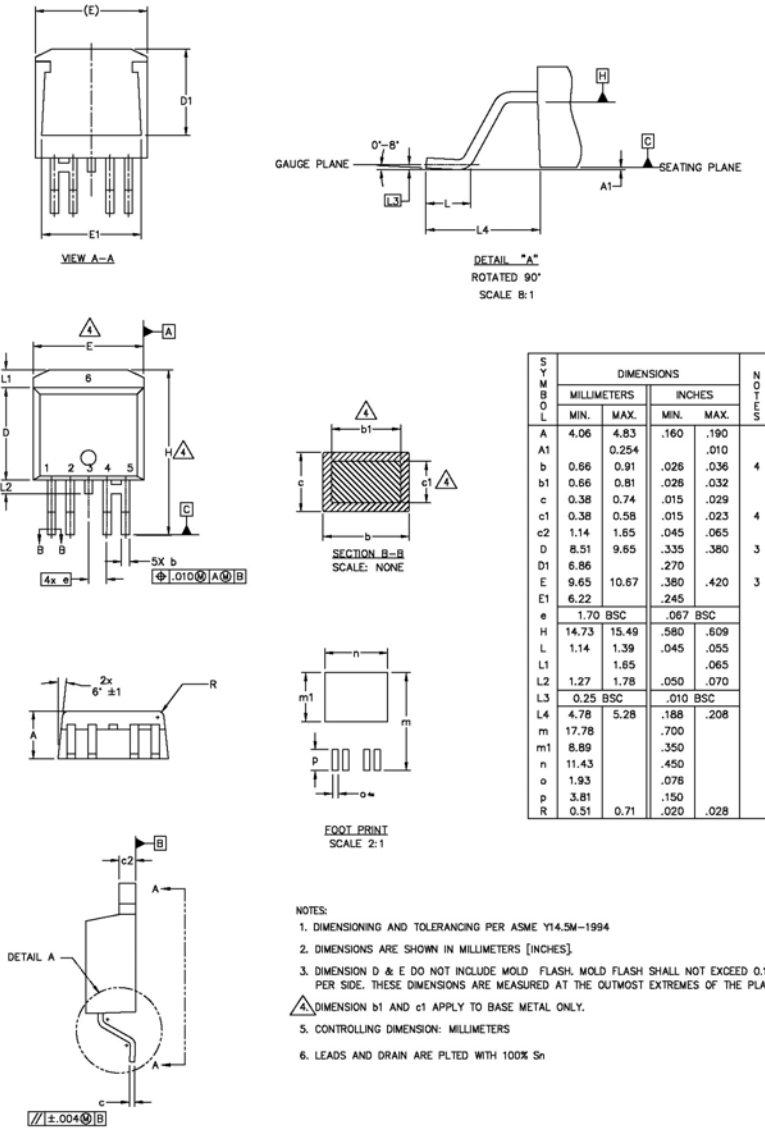

## Tape & Reel 5 Lead - D2PAK (SMD220)

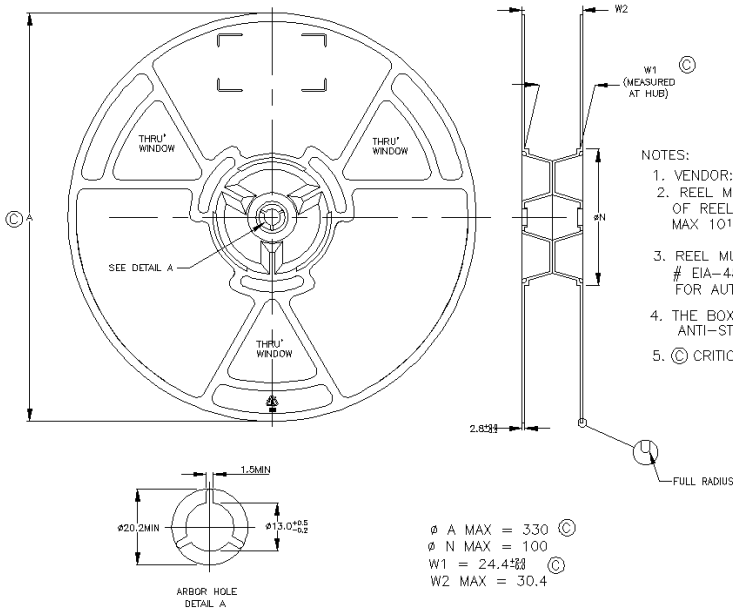

Case Outline 5 Leads – TO220 – Automotive Q100 PbF qualified

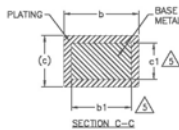
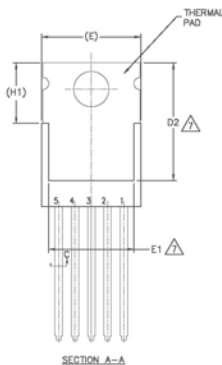
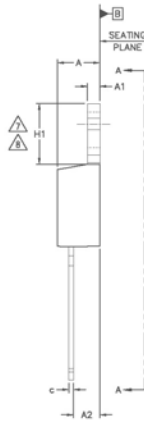
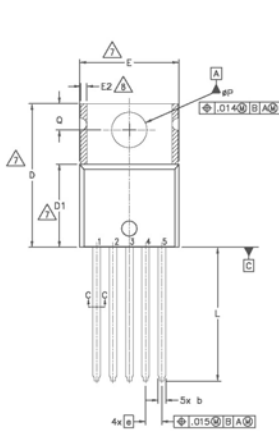

DIMENSIONS	DIMENSIONS				NOMINAL VALUE	
	MILLIMETERS		INCHES			
	MIN.	MAX.	MIN.	MAX.		
A	3.56	4.83	.140	.190	5	
A1	0.51	1.40	.020	.055		
A2	2.03	2.92	.080	.115		
b	0.64	0.89	.025	.035		
b1	0.64	0.84	.025	.033		
c	0.36	0.61	.014	.024		
c1	0.36	0.56	.014	.022		
D	14.22	16.51	.560	.650		4
D1	6.36	9.02	.330	.355		7
D2	11.68	12.88	.460	.507		
E	9.65	10.67	.380	.420	4,7	
E1	6.86	8.89	.270	.350	7	
E2	-	0.76	-	.030	8	
e	1.70 BSC		.067 BSC		7,8	
H1	5.84	6.86	.230	.270		
L	12.70	14.73	.500	.580	7	
ϕP	3.53	3.73	.139	.147		
Q	2.54	3.05	.100	.120		

- NOTES:
- 1.- DIMENSIONING AND TOLERANCING AS PER ASME Y14.5 M-1994.
  - 2.- DIMENSIONS ARE SHOWN IN INCHES [MILLIMETERS].
  - 3.- LEAD DIMENSION AND FINISH UNCONTROLLED IN L1.
  - 4.- DIMENSION D1, D1 & C DO NOT INCLUDE MOLD FLASH. MOLD FLASH SHALL NOT EXCEED .005" (0.127) PER SIDE. THESE DIMENSIONS ARE MEASURED AT THE OUTERMOST EXTREMES OF THE PLASTIC BODY.
  - 5.- DIMENSION B1 & C1 APPLY TO BASE METAL ONLY.
  - 6.- CONTROLLING DIMENSION - INCHES.
  - 7.- THERMAL PAD CONTOUR OPTIONAL WITHIN DIMENSIONS E,H1,D2 & E1.
  - 8.- DIMENSION E2 X H1 DEFINE A ZONE WHERE STAMPING AND SINGULATION IRREGULARITIES ARE ALLOWED.
  - 9.- OUTLINE CONFORMS TO JEDEC TO-220, EXCEPT A2 (max.) AND D3 (min.) WHERE DIMENSIONS ARE DERIVED FROM THE ACTUAL PACKAGE OUTLINE.
  - 10.- LEADS AND DRAIN ARE PLATED WITH 100% Sn